



MOTOR MOUNTED BRAKES
BRAKING UNLIMITED

Made in Germany

Motor mounted Brakes

PINTSCH BUBENZER

Content

Spring Set Brakes SFB Series	3 - 8
Spring Set Brake EFB-N	9 - 12
Spring Set Brake KFB	13 - 15
Accessories	17 - 23
Brake Control Unit BCU2001	25 - 27
Brake Control Unit BCMS-4	29 - 31

Spring Set Brakes SFB Series



PINTSCH BUBENZER
is certified according to
DIN EN ISO 9001:2015



Reliable



High Performance



Robust



Easy Maintenance



Compact



Tried and Trusted

Description SFB Series



Main Features

Spring applied safety brake
Electromechanically released
Protection-class IP67
Double wear reserve by single air gap adjustment
High work capacity
High wear resistance because of high abrasion resistance
Functional without cover
Emergency release screws

Applications

Gantry, trolley and hoisting applications
Electrical drives for ship winches and deck machinery
Jack up systems at offshore systems
Dynamic and static use at general industrial applications

Certificates

ABS, DNV, LR, GL, RMROS, BV

Options

Special brake torque:
Lower brake torque = type SFB
Higher brake torque = type SFB-SH
Holding brake torques available on request
Micro- or proximity switches:
• Monitoring the function on/off
• Maximum air gap (wear-monitoring)
Lateral junction box
Tacho preparation with all mounting parts
Cover bore
Shaft sealing
Special voltage
Anti condensation heater
Radial cable outlet
Special flange

Electrical equipment

One-way, bridge and switching rectifier
Protective element
Brake control unit = BCU 2001
Brake control and monitoring system = BCMS-4



Please Note

We supply a detailed operating manual with every order. Nevertheless, we would point out that brakes are only as safe as the servicing and maintenance performed while they are in operation. The guarantee for the correct functioning of our brakes is only valid if the user adheres to the German DIN standard 15434 part 2 (drum and disc brakes, servicing and maintenance in operation), or to comparable standards in his own country.



PINTSCH BUBENZER Service

This includes the verification of the brake selection, if required. A detailed questionnaire is provided for this purpose. Installation and commissioning on-site by PINTSCH BUBENZER service engineers is possible. Drawings as DWG/DXF files for your engineering department are available upon request.

Spring Set Brake SFB

Electromagnetic Two Disc, Spring Set Brake



Rev. 05-08

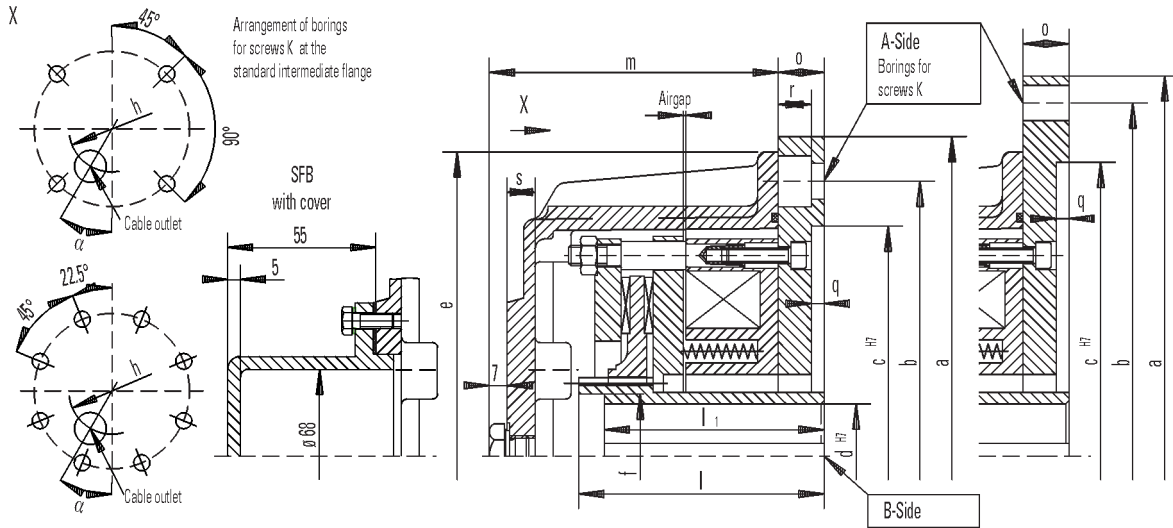

Keyways for keys acc. to DIN6885 BI.1, width accuracy P9. Protection IP67

Alterations reserved without notice

Brake size		SFB 6.3	SFB 10	SFB 16	SFB 25	SFB 40	SFB 63	SFB 100	SFB 160	SFB 250			
Brake torque M2 dynamic acc. to DIN VDE 0580	Nm	63	100	160	250	400	630	1000	1600	2500			
		54	80	130	210	330	520	830	1300	2100			
		45	63	100	180	260	400	660	1050	1650			
Mass moment of inertia	kgm ²	0.0017	0.0037	0.0048	0.0068	0.0175	0.036	0.050	0.128	0.140			
Mass (weight)	kg	19	28	42	55	74	106	168	242	306			
max. speed	min ⁻¹	6000	6000	6000	5500	4700	4000	3600	3200	2800			
Coil b. 20° C	Nominal voltage	V DC	110	110	110	110	110	110	110	110			
	Nominal power	W	99	128	158	196	220	307	344	435			
	Nominal current	A	0.90	1.16	1.44	1.78	2.0	2.79	3.13	3.95			
Air gap, brake OFF	min. mm	0.3	0.3	0.3	0.4	0.4	0.4	0.6	0.4	0.4			
	max. mm	0.9	1.2	1.2	1.3	1.4	1.8	1.8	2.3	2.5			
Diameter mm	B-Side	d Rough boring	26	26	36	36	36	36	46	46			
		d ^{H7} Preferential boring	28	28	38	38	48	60	60	65			
			32	32	42	42	55	65	65	70			
			38	38	48	48	60	75	75	75			
					55	55				80	80		
								90	90				
		d ^{H7} maximal	40	40	55	55	60	75	75	110			
Length mm	e	238	260	280	318	400	440	446	540	556			
	f						95	95	128	128			
	h	150	180	202	214	244	292	330	394	440			
	l	96	96	117	117	142	148	148	191	191			
	l ¹	96	96	117	117	142	142	142	171	171			
	m	115	118	137	143	169	171	183	211	232			
	s	11	11	11	12	14	15	15	15	15			
A	α°	15	15	30	22.5	30	30	30	30	45			
Suitable standard Intermediate flange		A250	A300	A300-1	A350	A400-1	A450-1	A450-1	A550-1	A660			
		A300	A350	A350	A400	A450	A550	A550	A660	A800			
				A400	A450	A550	A660	A660	A800				
				A450									
Dimensions of standard intermediate flanges													
Standard intermediate flange		A250	A300	A300-1	A350	A400	A400-1	A450	A450-1	A550	A550-1	A660	A800
Diameter mm	a	250	300	300	350	400	400	450	450	550	550	660	800
	b	215	265	265	300	350	350	400	400	500	500	600	740
	c ^{H7}	180	230	230	250	300	300	350	350	450	450	550	680
Length mm	o	18	18	18	20	22	22	24	24	24	24	30	30
	q	5	5	5	6	6	6	6	6	6	6	7	7
	r	13		13			17.5		17.5		17.5		
	k	4xM12	4xM12	4xM12	4xM16	4xM16	4xM16	4xM12	8xM16	8xM16	8xM16	8xM20	8xM20

Spring Set Brake SFB

Electromagnetic Two Disc, Spring Set Brake



Rev. 05-08

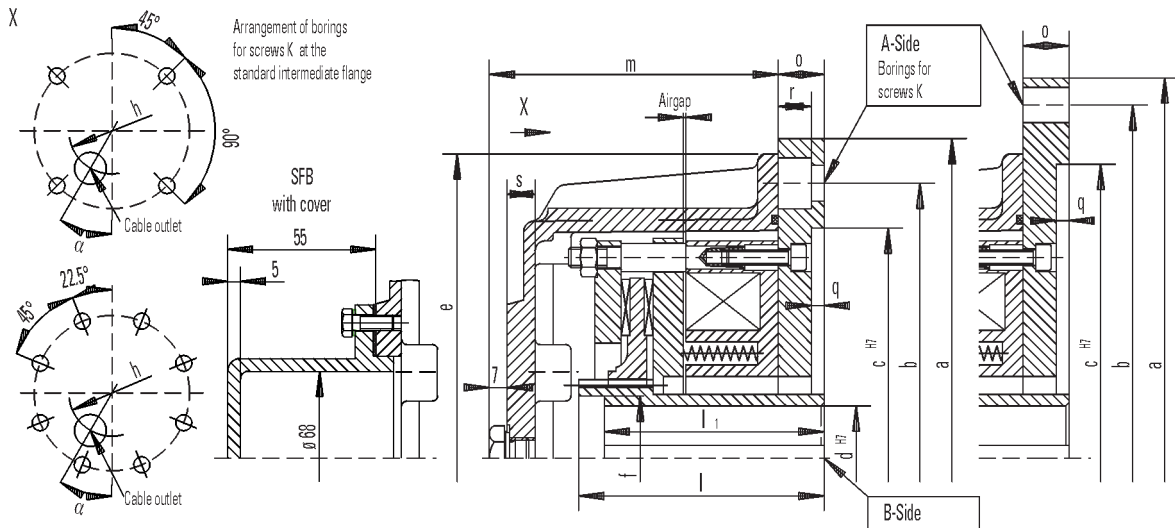

Brake size		SFB	SFB	SFB
		400	630	1000
Brake torque M2 dynamic acc. to DIN VDE 0580		Nm		
		4000	6300	10000
		3350	5250	8500
		2650	4200	7000
Mass moment of inertia		kgm ²	0.325	0.375
Mass (weight)		kg	357	500
max. speed		min ⁻¹	2500	2200
Coil C b. 20° C		Nominal voltage	V DC	110
		Nominal power	W	553
		Nominal current	A	5.03
Air gap, brake OFF		min. mm	0.4	0.7
		max. mm	2.5	2.8
Diameter mm	B-Side	d Rough boring	46	58
		d ^{H7} Preferential boring	65	100
			70	
			75	
			80	
			90	
			d ^{H7} maximal	110
Length mm	e	660	700	
	f	128	140	
	h	520	570	
	l	191	237	
	l ¹	171	210	
	m	272	310	
	s	15	15	
A	α°	30	30	
Suitable standard intermediate flange		A660-1	A800	A800-1
		A800		
		Dimensions of standard intermediate flange		
Standard intermediate flange		A660-1	A800	A800-1
Diameter mm	a	660	800	800
	b	600	740	740
	c ^{H7}	550	680	680
Length mm	o	30	30	30
	q	7	7	7
	r	21.5		21.5
Screws k		8xM20	8xM20	8xM20

Keyways for keys acc. to DIN6885 Bl.1, width accuracy P9. Protection IP67

Alterations reserved without notice

Spring Set Brake SFB-SH

Electromagnetic Two Disc, Spring Set Brake
Increased brake torque



Rev. 05-08

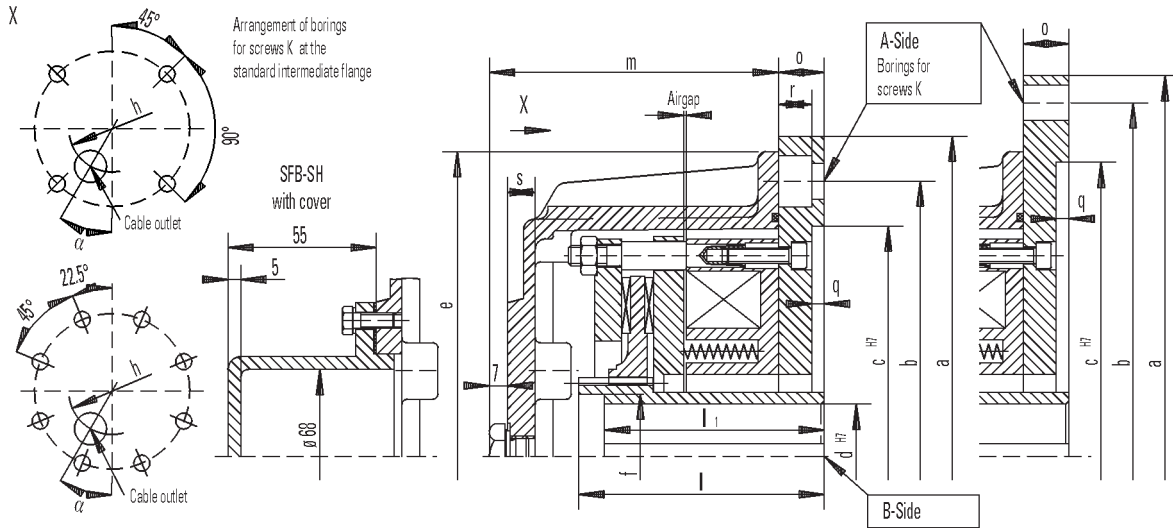

Keyways for keys acc. to DIN6885 BI.1,
width accuracy P9. Protection IP67

Alterations reserved without notice

Brake size		SFB 6.3-SH	SFB 10-SH	SFB 16-SH	SFB 25-SH	SFB 40-SH	SFB 63-SH	SFB 100-SH	SFB 160-SH	SFB 250-SH			
Brake torque M2 dynamic acc. to DIN VDE 0580	Nm	80	130	210	350	550	800	1300	2100	3300			
		75	120	190	310	490	750	1200	1900	3000			
		69	110	180	275	440	690	1100	1750	2750			
Mass moment of inertia	kgm ²	0.0017	0.0037	0.0048	0.0068	0.0175	0.036	0.050	0.128	0.140			
Mass (weight)	kg	19	28	42	55	74	106	168	242	306			
max. speed	min ⁻¹	6000	6000	6000	5500	4700	4000	3600	3200	2800			
Coil b. 20° C	Nominal voltage	V DC	110	110	110	110	110	110	110	110			
	Nominal power	W	99	128	158	196	220	307	344	435			
	Nominal current	A	0.90	1.16	1.44	1.78	2.0	2.79	3.13	3.95			
Air gap, brake OFF	min. mm	0.3	0.3	0.3	0.4	0.4	0.4	0.6	0.4	0.4			
	max. mm	0.9	1.2	1.2	1.3	1.4	1.8	1.8	2.3	2.5			
Diameter mm	B-Side	d Rough boring	26	26	36	36	36	36	36	46	46		
		d ^{H7} Preferential boring	28	28	38	38	48	60	60	65	65		
			32	32	42	42	55	65	65	70	70		
			38	38	48	48	60	75	75	75	75		
					55	55				80	80		
d ^{H7} maximal	40	40	55	55	60	75	75	110	110				
Length mm	e	238	260	280	318	400	440	446	540	556			
	f						95	95	128	128			
	h	150	180	202	214	244	292	330	394	440			
	l	96	96	117	117	142	148	148	191	191			
	l ¹	96	96	117	117	142	142	142	171	171			
	m	115	118	137	143	169	171	183	211	232			
	s	11	11	11	12	14	15	15	15	15			
A	α°	15	15	30	22.5	30	30	30	30	45			
Suitable standard intermediate flange	A250	A300	A300-1	A350	A400-1	A450-1	A450-1	A550-1	A660				
	A300	A350	A350	A400	A450	A550	A550	A660	A800				
			A400	A450	A550	A660	A660	A800					
			A450										
Dimensions of standard intermediate flange													
Standard intermediate flange		A250	A300	A300-1	A350	A400	A400-1	A450	A450-1	A550	A550-1	A660	A800
Diameter mm	a	250	300	300	350	400	400	450	450	550	550	660	800
	b	215	265	265	300	350	350	400	400	500	500	600	740
	c ^{H7}	180	230	230	250	300	300	350	350	450	450	550	680
Length mm	o	18	18	18	20	22	22	24	24	24	24	30	30
	q	5	5	5	6	6	6	6	6	6	6	7	7
	r	13		13			17.5		17.5		17.5		
	Screws	k	4xM12	4xM12	4xM12	4xM16	4xM16	4xM16	8xM16	8xM16	8xM16	8xM16	8xM20

Spring Set Brake SFB-SH

Electromagnetic Two Disc, Spring Set Brake
Increased brake torque



Rev. 05-08

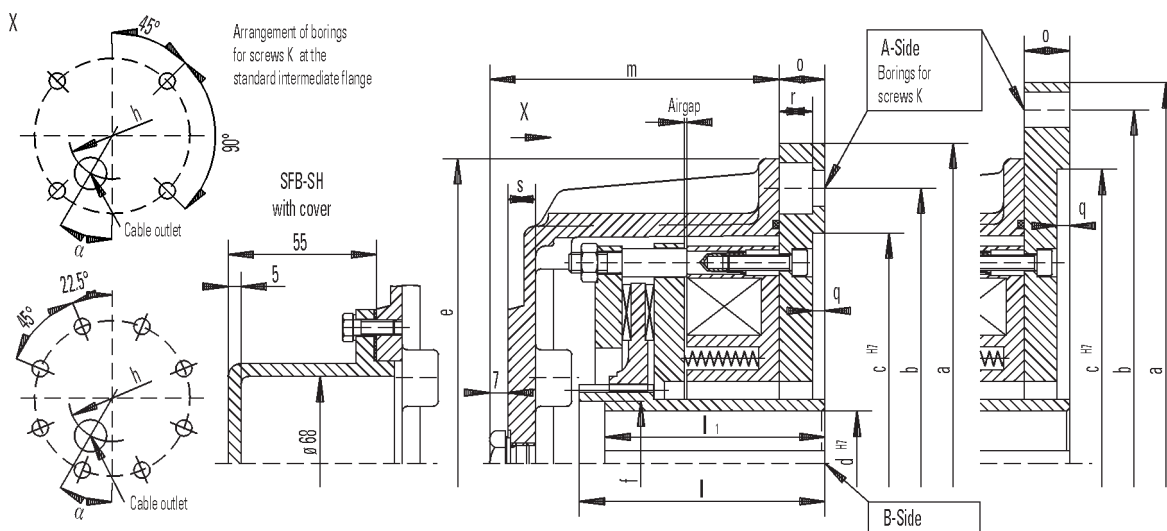

Brake size		SFB 400-SH	SFB 630-SH	SFB 1000-SH	
Brake torque M2 dynamic acc. to DIN VDE 0580	Nm	5200	8000	13000	
		4800	7500		
		4400	6900		
Mass moment of inertia	kgm ²	0.325	0.375	1.007	
Mass (weight)	kg	357	500	750	
max. speed	min ⁻¹	2500	2200	2000	
Coil C b. 20° C	Nominal voltage	V DC	110	110	110
	Nominal power	W	553	671	980
	Nominal current	A	5.03	6.10	8.91
Air gap, brake OFF		min. mm	0.4	0.7	0.7
		max. mm	2.5	2.8	3.1
Diameter mm	B-Side	d Rough boring	46	58	68
		d ^{H7} Preferential boring	65	100	125
			70		
			75		
			80		
			90		
d ^{H7} maximal	110	125	140		
Length mm	e	660	700	795	
	f	128	140	155	
	h	520	570	620	
	l	191	237	282	
	l ¹	171	210	255	
	m	272	310	360	
	s	15	15	15	
A	α°	30	30	30	
Suitable standard intermediate flange		A660-1	A800	A800-1	
		A800			
Dimensions of standard intermediate flange					
Standard intermediate flange		A660-1	A800	A800-1	
Diameter mm	a	660	800	800	
	b	600	740	740	
	c ^{H7}	550	680	680	
Length mm	o	30	30	30	
	q	7	7	7	
	r	21.5		21.5	
Screws k		8xM20	8xM20	8xM20	

Keyways for keys acc. to DIN6885 Bl.1,
width accuracy P9. Protection IP67

Alterations reserved without notice

Spring Set Brake EFB-N



PINTSCH BUBENZER
is certified according to
DIN EN ISO 9001:2015



Reliable



High Performance



Robust



Easy Maintenance



Compact



Tried and Trusted

Description EFB-N



Main Features

■	Spring applied safety brake
■	Electromechanically released
■	Protection-class IP 54
■	Small compact design
■	Approved design

Applications

■	General industrial applications
■	Warehouse equipment
■	Automation systems
■	Industrial transportation equipment e.g. E-forklifter

Options

■	Handlever
■	Micro- or proximity switch: Monitoring the function on/off Maximum air gap (wear monitoring)
■	Special voltage
■	Anti condensation heater
■	Shaft sealing
■	Tacho preparation with all mounting parts
■	Sealring for shaft through
■	Reduced brake torque available

Electrical equipment

■	One-way-, bridge- and switching rectifier
■	Protection element



Please Note

We supply a detailed operating manual with every order. Nevertheless, we would point out that brakes are only as safe as the servicing and maintenance performed while they are in operation. The guarantee for the correct functioning of our brakes is only valid if the user adheres to the German DIN standard 15434 part 2 (drum and disc brakes, servicing and maintenance in operation), or to comparable standards in his own country.



PINTSCH BUBENZER Service

This includes the verification of the brake selection, if required. A detailed questionnaire is provided for this purpose. Installation and commissioning on-site by PINTSCH BUBENZER service engineers is possible. Drawings as DWG/DXF files for your engineering department are available upon request.

Spring Set Brake EFB-N

Electromagnetic Two Disc, Spring Set Brake



Rev. 03-14

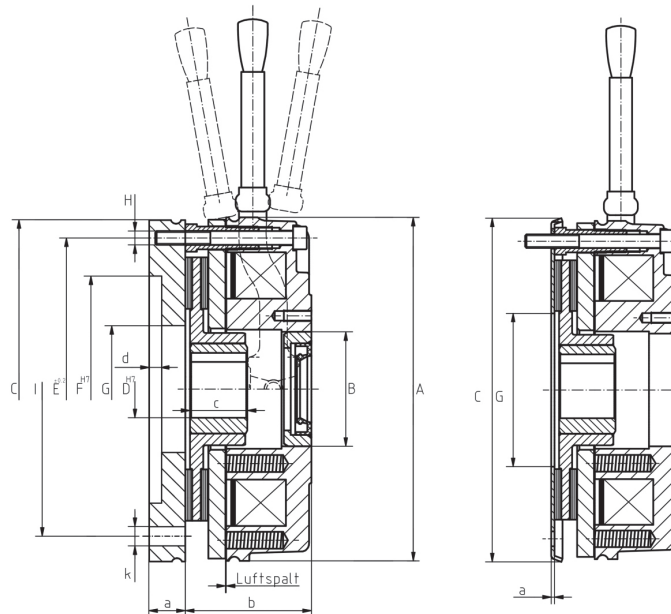

Nuts for keys according to DIN 6885 sheet 1, tolerance field for the nuts width P9.
Technical, measures and design are subject to change.

Alterations reserved without notice.

Brake size		EFB-N 1	EFB-N 2	EFB-N 3,5	EFB-N 6	EFB-N 9	EFB-N 12	
Brake torque DIN VDE 0580	Nm	10	20	35	60	90	120	
Mass moment of inertia	kg*cm ²	0,15	0,61	2,0	4,5	6,3	15	
Mass (weight)	kg	0,75	1,3	2,2	3,6	5,3	8,0	
max. speed	1/min	6000	5000	4000	3600	3600	3600	
Coil b.20°C	Nominal voltage	V-	110 / 207	110 / 207	110 / 207	110 / 207	110 / 207	
	Nominal power	A	0,24 / 0,13	0,33 / 0,17	0,27 / 0,15	0,38 / 0,20	0,51 / 0,27	
	Nominal current	W	26	36	30	42	56	65
Airgap, OFF	Norm. mm	0,2	0,2	0,2	0,3	0,3	0,3	
	Max. mm	0,5	0,5	0,5	0,75	0,75	0,75	
Diameter mm	A-Side	D pilot bore	9	9	9	13	18	23
		D preferential bore H7	11	15	15	20	25	30
		D max. bore H7	15	20	20	27	31	38
	A		87	105	130	150	165	190
	B		25	32	42	50	60	68
	C		90	100 / 120	140	160	160	200
	E	±0,2	72	90	112	132	145	170
	F	H7	60	70 / 80	95	110	110	130
G		31	41	45	52	55	70	
H		3xM4	3xM5	3xM6	3xM6	3xM8	3xM8	
Length mm	a		6	7	9	9	11	11
	b		37,3	44	48,4	54,9	67,8	74,5
	c	0,2	18	20	20	25	30	30
	d		2,5	2,5/3	3	3,5	3,5	3,5
<	α°		25	25	25	25	25	25

Spring Set Brake EFB-N

Electromagnetic Two Disc, Spring Set Brake



Rev. 03-14

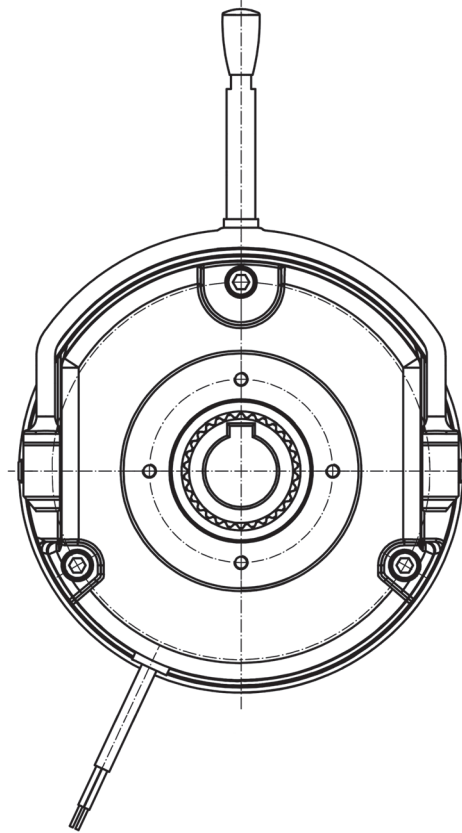

Nuts for keys according to DIN 6885 sheet 1, tolerance field for the nuts width P9.
Technical, measures and design are subject to change.

Alterations reserved without notice.

Friction plate

Size of friction plate		R90	R110	R135	R155	R170	R195
Diameter	mm						
	C	86	106	132	153	169	194
	G	36	45	52	68	78	90
Length	mm	a	1,5	1,5	1,5	1,5	1,5

Dimensions of standard flanges

Size of standards flanges (FF/IEC)		FF90	FF100 / A120	A140	A160	A160	A200
Diameter	mm						
	C	90	100 / 120	140	160	160	200
	l (FF)	75	85 / 100	115	130	130	165
	F H7	60	70 / 80	95	110	110	130
Length	mm	a	6	7	9	9	11
	d	2,5	2,5 / 3	3	3,5	3,5	3,5
Screws	k	4xM5	4xM6	4xM8	4xM8	4xM8	4xM10

Spring Set Brake KFB



PINTSCH BUBENZER
is certified according to
DIN EN ISO 9001:2015



Reliable



High Performance



Robust



Easy Maintenance



Compact



Tried and Trusted

Description KFB



Main Features

Spring applied safety brake
Electromechanically released
Protection-class IP67 – seawater protected
High wear reserve by multiple air gap adjustment
Small construction at high work capacity
High availability caused by high durability
Functional without cover
Emergency release screws

Applications

Gantry, trolley and hoisting application
Dynamic and static use at general industrial applications
General engineering
Steel mills
Wind energy systems
Coal mining

Certificates

ABS, Atex

Options

Special brake torque
Handlever
Micro or proximity switch: <ul style="list-style-type: none">• Monitoring the function on/off• Maximum air gap (wear-monitoring)
Lateral junction box
Tacho preparation with all mounting parts
Cover bore
Shaft sealing
Special voltage
Anti condensation heater
Radial cable outlet
Special flange

Electrical equipment

One-way, bridge and switching rectifier
Protective element
Brake control unit = BCU 2001
Brake control and monitoring system = BCMS-4



Please Note

We supply a detailed operating manual with every order. Nevertheless, we would point out that brakes are only as safe as the servicing and maintenance performed while they are in operation. The guarantee for the correct functioning of our brakes is only valid if the user adheres to the German DIN standard 15434 part 2 (drum and disc brakes, servicing and maintenance in operation), or to comparable standards in his own country.



PINTSCH BUBENZER Service

This includes the verification of the brake selection, if required. A detailed questionnaire is provided for this purpose. Installation and commissioning on-site by PINTSCH BUBENZER service engineers is possible. Drawings as DWG/DXF files for your engineering department are available upon request.

Spring Set Brake KFB

Electromagnetic Two Disc, Spring Set Brake



Rev. 10-09

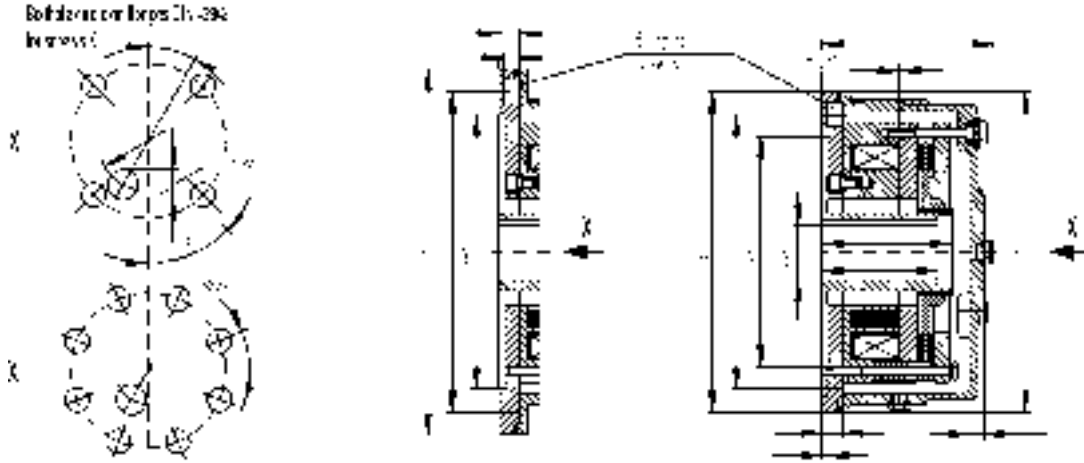

* The larger dimension belongs to the larger assigned brake.

Alterations reserved without notice.

Brake size		KFB 5	KFB 10	KFB 16	KFB 25	KFB 30	KFB 40	KFB 63	KFB 100	KFB 160	
Brake torque M2 dynamic acc. to DIN VDE 0580 Nm		50	100	160	250	300	400	630	1000	1600	
Mass moment of inertia kgm ²		0.0010	0.0017	0.0037	0.0048	0.0055	0.0068	0.0175	0.036	0.050	
Mass (weight) kg		13	19	28	42	50	55	74	106	168	
max. speed min ⁻¹		6000	6000	6000	6000	6000	5500	4700	4000	3600	
Coil c b, 20° C	Nominal voltage V DC	110	110	110	110	110	110	110	110	110	
	Nominal power W	79	93	128	158	133	196	220	307	344	
	Nominal current A	0.72	0.84	1.16	1.44	1.2	1.78	2.0	2.79	3.13	
Air gap, OFF		norm. mm	0.3	0.3	0.3	0.3	0.3	0.4	0.4	0.4	
		max. mm	0.8	1.0	1.0	1.2	0.8	1.2	1.3	1.6	1.8
Diameter mm	B-Side	d pilot bore	8	26	26	36	26	36	36	36	36
		d ^{H7} preferential bore	15	28	28	38	32	38	48	60	60
			20	32	32	42	38	42	55	65	65
			25	38	38	48	42	48	60	75	75
						55	45	55			
Length mm	e	160/200	200/250	253/303	300/350	250/300	303/350	350/400	400/450	450/550	
	f										
	h	93	106	144	194	144	194	214	264	314	
	l	110	110	96	117	137	117	142	148	155	
	l ¹	110	110	96	117	137	117	142	142	142	
	m	145	154	141	165	175	175	187	196	218	
	s	13	15	15	15	15	15	15	15	17	
A	α °	22.5	30	30	30	67.5	30	30	30	30	
Suitable standards flanges		A160	A200	A250	A300	A250	A300	A350	A400	A450	
		A200	A250	A300	A350	A300	A350	A400	A450	A550	
		Dimensions of standards flanges									
Size of standards flanges		A160	A200	A250	A300	A350	A400	A450	A550		
Diameter mm	a	160	200	250	300	350	400	450	550		
	b	130	165	215	265	300	350	400	500		
	c ^{H7}	110	130	180	230	250	300	350	450		
Length mm	o	18	18	18/20*	20/22*	22	22/24*	24/29*	24/29*		
	q	5	5	5	5	6	6	6	6		
	r	11	11	13	13	17.5	17.5	17.5	17.5		
	Screws k	4xM8	4xM10	4xM12	4xM12	4xM16	4xM16	8xM16	8xM16		

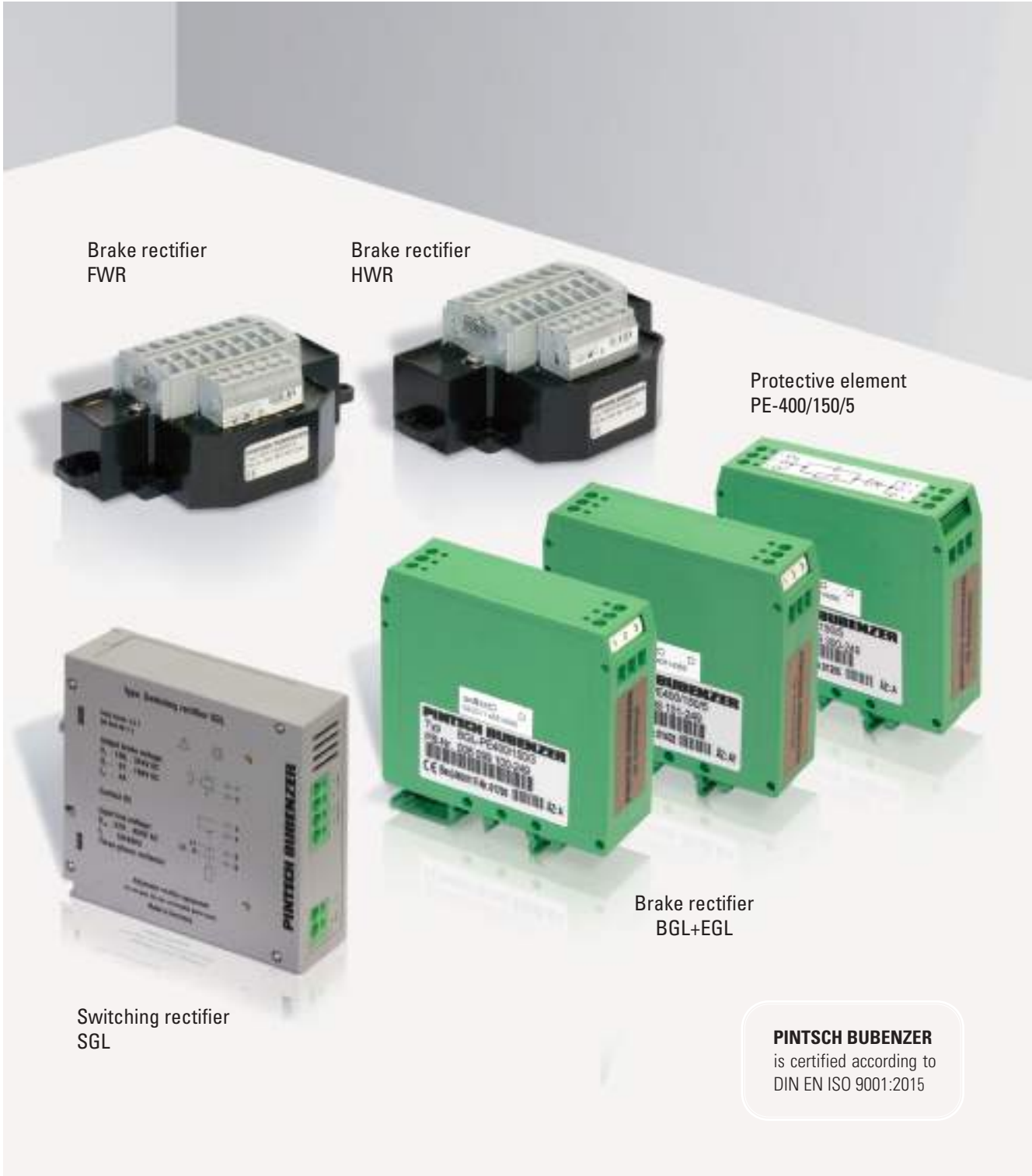

Brake rectifier
FWR

Brake rectifier
HWR

Protective element
PE-400/150/5

Switching rectifier
SGL

Brake rectifier
BGL+EGL

PINTSCH BUBENZER
is certified according to
DIN EN ISO 9001:2015



Reliable



High Performance



Robust



Easy Maintenance



Compact



Tried and Trusted

Description Accessories



Main Features

EMC compatibility
Top-hat rail mounted
Combinable with Brake Control Unit BCU2001
Integrated protective element
Integrated spark quench element

Specific Features for the rectifiers BGL and EGL

Prepared for switching AC and DC circuits simultaneously
Installation in cabinet

Specific Features for the protective element PE 400/150/5

To be connected parallel to the output of the rectifiers BGL, EGL and SGL to increase the interruption capacity

Specific Features for the rectifiers FWR and HWR

Prepared for switching AC and DC circuits simultaneously
Installation in junction box

Specific Features of the switching rectifier SGL

Prepared for switching AC and DC circuits simultaneously
Switches from bridge rectification to half-wave rectification
Four time settings 0,5 s, 1 s, 1,5 s, 2 s adjustable
Applying brakes at elevated temperatures
Accelerated brake release (Overexcitation with AC power supply voltage = 2 x DC coil voltage)
Accelerated brake effect (Standard excitation with AC power supply voltage = DC coil voltage)



Please Note

We supply a detailed operating manual with every order. Nevertheless, we would point out that brakes are only as safe as the servicing and maintenance performed while they are in operation. The guarantee for the correct functioning of our brakes is only valid if the user adheres to the German DIN standard 15434 part 2 (drum and disc brakes, servicing and maintenance in operation), or to comparable standards in his own country.



PINTSCH BUBENZER Service

This includes the verification of the brake selection, if required. A detailed questionnaire is provided for this purpose. Installation and commissioning on-site by PINTSCH BUBENZER service engineers is possible. Drawings as DWG/DXF files for your engineering department are available upon request.

BGL-PE400/150/3 - EGL-PE400/150/5

Principal circuit diagram



Rev. 03-09

Bridge rectification with module BGL

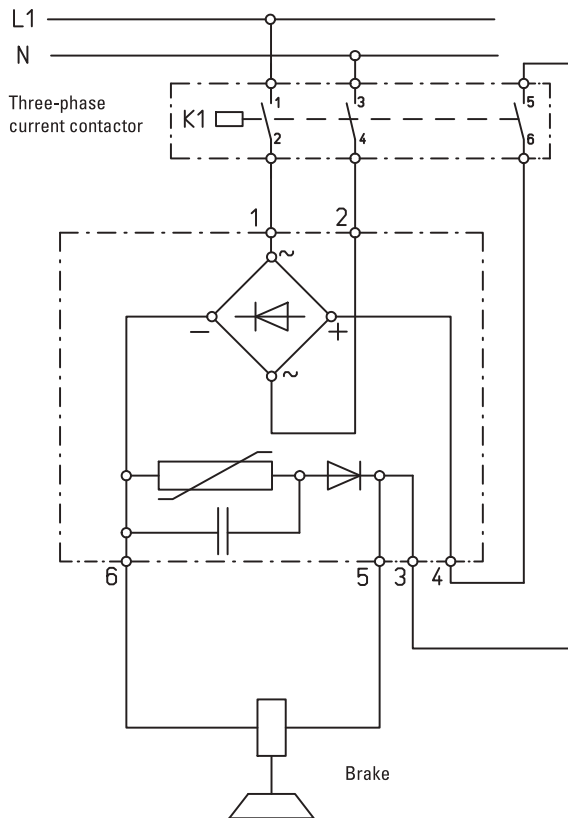

Half-wave rectification with module EGL

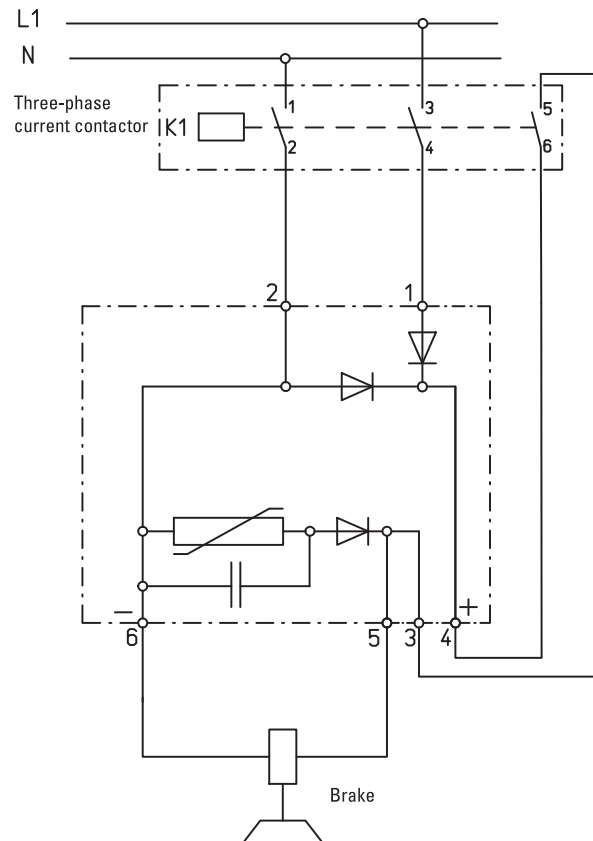

Technical data

Brake rectifier BGL-PE400/150/3	
AC line voltage:	AC 460V; 50/60 Hz
Permissible rated coil voltages:	DC 24V...390V
Maximum brake current:	2,5A
Maximum continuous output of the internal protective circuit:	3W
Disconnection peak at maximum coil current:	≤450V
Ambient temperature:	-40° C ... +50° C
Protection class:	IP 20

Brake rectifier EGL-PE400/150/5	
AC line voltage:	AC 460V; 50/60 Hz
Permissible rated coil voltages:	DC 24V...220V
Maximum brake current:	5A
Maximum continuous output of the internal protective circuit:	5W
Disconnection peak at maximum coil current:	≤450V
Ambient temperature:	-40° C ... +50° C
Protection class:	IP 20

Full wave rectifier FWR-PE400/150/3

Principal circuit diagram



Rev. 10-10

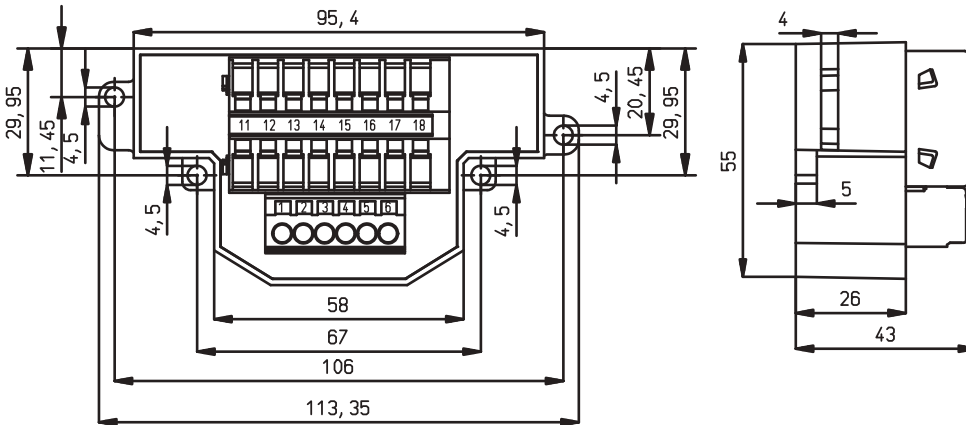
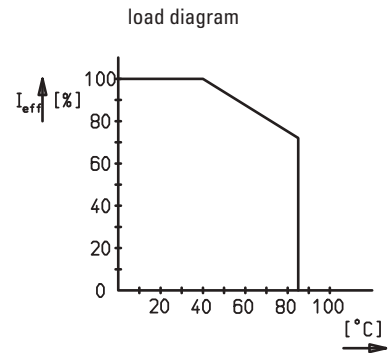
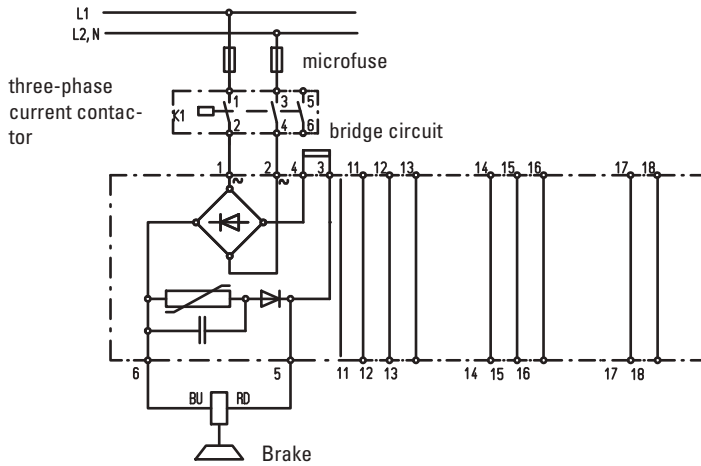

Technical data

Coil voltage of the connected brake	DC 24V ... 390V
Max. voltage of supplying alternating current network	AC 460V - 50/60 Hz
Max. Output current I_{eff} at $T_A = < 50^\circ C$	2,5 A
Max. Output current I_{eff} at max. T_A $85^\circ C$	1,8 A
Protection fuse in the AC input voltage line to the rectifier (In the selection of fuse is permissible on the $I^2 t$ limit load integral to eight)	FF 4A microfuse switching capacity H
Permitted limit integral $I^2 t$	700A ² s (t < 10ms)
Max. energy absorption of a shut-off	150 J
Max. continuous power of the internal protective circuit (average value)	3W
Shut-off peak at max. coil current	< 450V
Ambiente temperature T_A	-40° C ... +85° C
Permissible cross section of connection wire	0,2 ... 2,5 mm AWG 24 ... 14
Weight	0,3 kg
Protection class	IP 65 components seal / IP20 terminals
Mark of conformity	CE / RoHS conform

Half wave rectifier HWR-PE400/150/5

Principal circuit diagram



Rev. 10-10

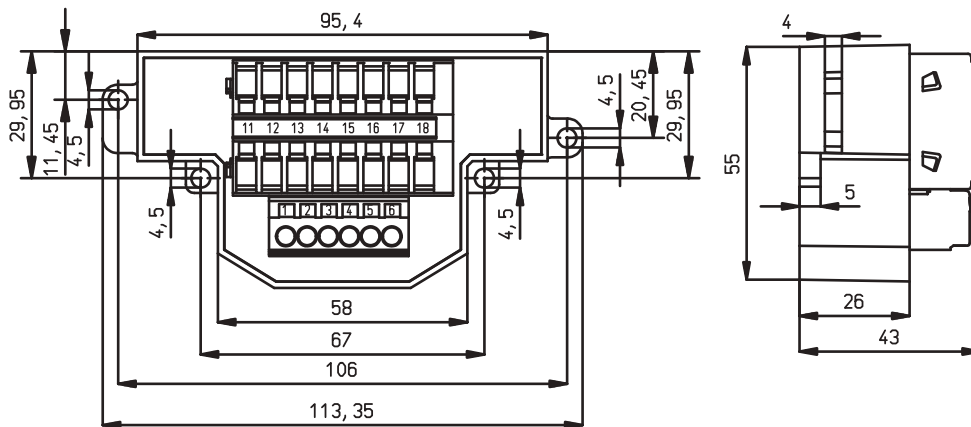
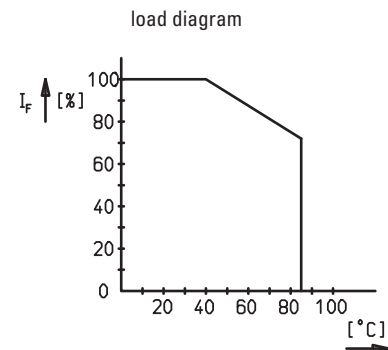
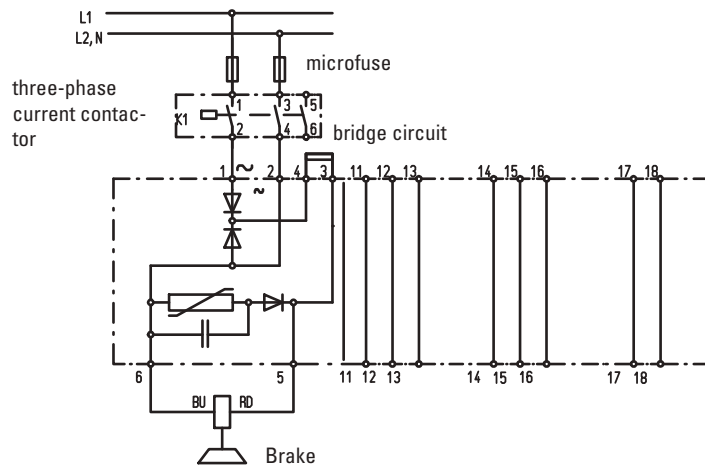

Technical data

Coil voltage of the connected brake	DC 24V ... 240V
Max. voltage of supplying alternating current network	AC 550V - 50/60 Hz
Max. Output current I_{eff} at $T_A = < 50^\circ\text{C}$	5 A
Max. Output current I_{eff} at max. T_A 85°C	3,6 A
Protection fuse in the AC input voltage line to the rectifier (In the selection of fuse is permissible on the $I^2 t$ limit load integral to eight)	FF 4A microfuse switching capacity H
Permitted limit integral $I^2 t$	700A ² s (t < 10ms)
Max. energy absorption of a shut-off	150 J
Max. continuous power of the internal protective circuit (average value)	5W
Shut-off peak at max. coil current	< 450V
Ambiente temperature T_A	-40° C ... +85° C
Permissible cross section of connection wire	0,2 ... 2,5 mm AWG 24 ... 14
Weight	0,3 kg
Protection class	IP 65 components seal / IP20 terminals
Mark of conformity	CE / RoHS conform

Switching rectifier SGL

Principal circuit diagram



Rev. 03-09

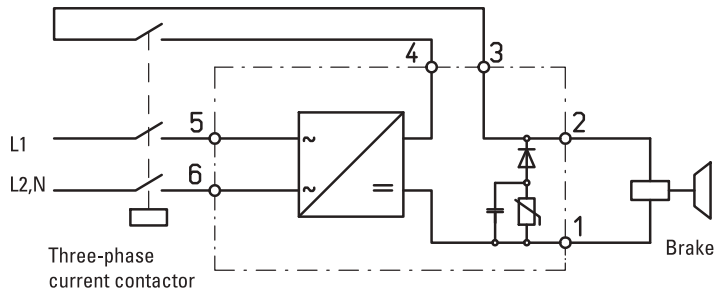

Switching rectification with module SGL

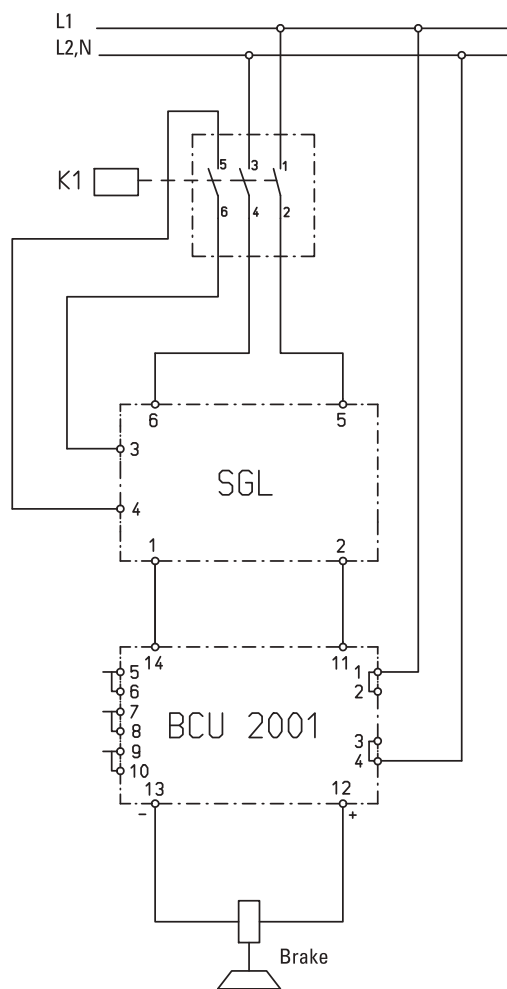

Switching rectification with module SGL combined with the Brake Control Unit BCU2001

Technical data

AC line voltage:	AC 220V...484V; 50/60 Hz
Maximum brake current for 2 s:	8A
Maximum continuous output of the internal protective circuit:	5 W
Permanent brake current:	4A
Time settings by DIP switch:	0,5 s, 1 s, 1,5 s, 2,0 s
Ambient temperature:	-40° C ... +50° C
Protection class:	IP 20

Protective element PE-400/150/5

Principal circuit diagram



Rev. 03-09

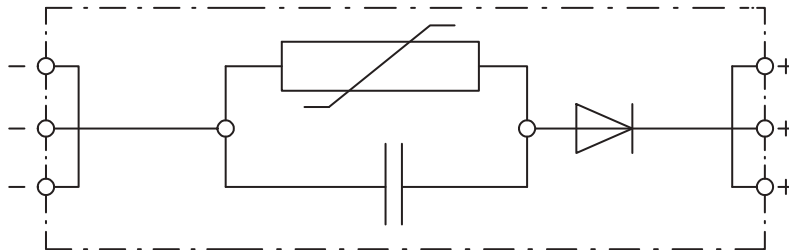

Protective element
PE-400/150/5

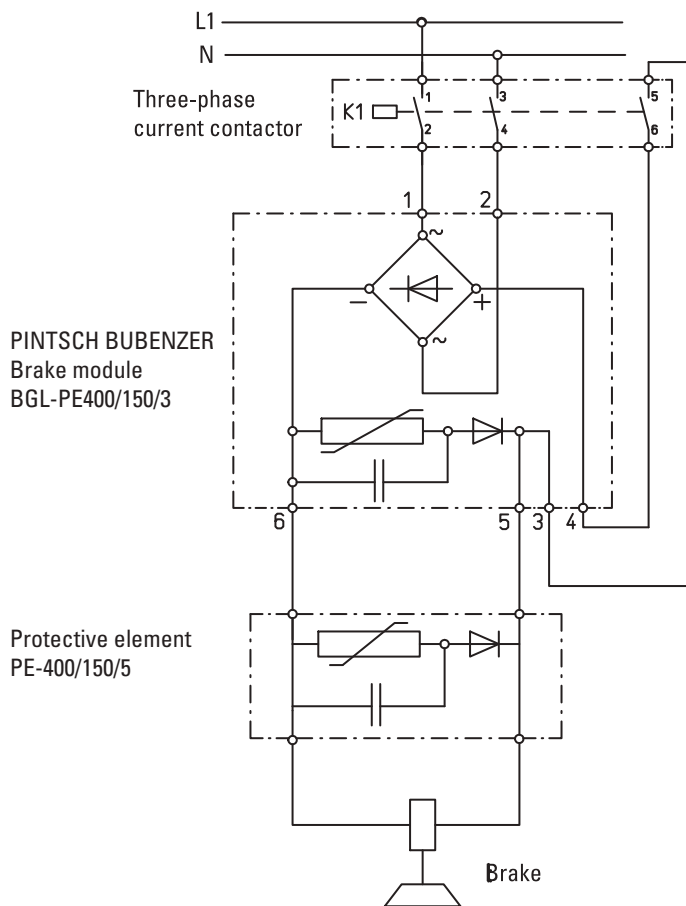

Bridge rectification with
module BGL combined
with the protective element
PE-400/150/5

Technical data

Maximum brake voltage:	DC 400V
Maximum brake current:	5A
Maximum continuous output of the internal protective circuit:	5W
Disconnection peak at maximum coil current:	≤ 450V
Ambient temperature:	-40° C ... +50° C
Protection class:	IP 20

Brake Control Unit BCU2001



PINTSCH BUBENZER
is certified according to
DIN EN ISO 9001:2015



Reliable



High Performance



Robust



Easy Maintenance



Compact



Tried and Trusted

Description Brake Control Unit BCU2001



Main Features

EMC compatibility
Maximum air gap (wear) indication by LED
Maximum air gap indication by relay contact
Function on/off indication by LED
Function on/off indication by relay contact
No sensors on the brake
No sensor wiring to the brake
Perfect retrofit equipment
Directly connectable with PLC systems
AC and DC auxiliary power supplies applicable
Top-hat rail mounted

Applications

Container cranes
Ship winches
Automatic racking systems
Conveyor belts
General electrical drives

Options

Combinable with the switching rectifier SGL in overexcitation mode
Combinable with bridge rectifier BGL-PE400/150/3
Combinable with half-wave rectifier EGL-PE400/150/3

Method

The Brake Control Unit BCU 2001 records characteristic current and voltage variations, which are induced by movements of the armature disk in the magnetic field of the brake coil. In an interference free and reliable manner it evaluates the signal levels in terms of the control state (applied or released) and the maximum air gap (maximum wear)

Important requirements

AC and DC circuit to be switched simultaneously
AC circuit may not be switched alone



Please Note

We supply a detailed operating manual with every order. Nevertheless, we would point out that brakes are only as safe as the servicing and maintenance performed while they are in operation. The guarantee for the correct functioning of our brakes is only valid if the user adheres to the German DIN standard 15434 part 2 (drum and disc brakes, servicing and maintenance in operation), or to comparable standards in his own country.



PINTSCH BUBENZER Service

This includes the verification of the brake selection, if required. A detailed questionnaire is provided for this purpose. Installation and commissioning on-site by PINTSCH BUBENZER service engineers is possible. Drawings as DWG/DXF files for your engineering department are available upon request.

Brake Control Unit BCU2001

Principal circuit diagram



Rev. 03-09

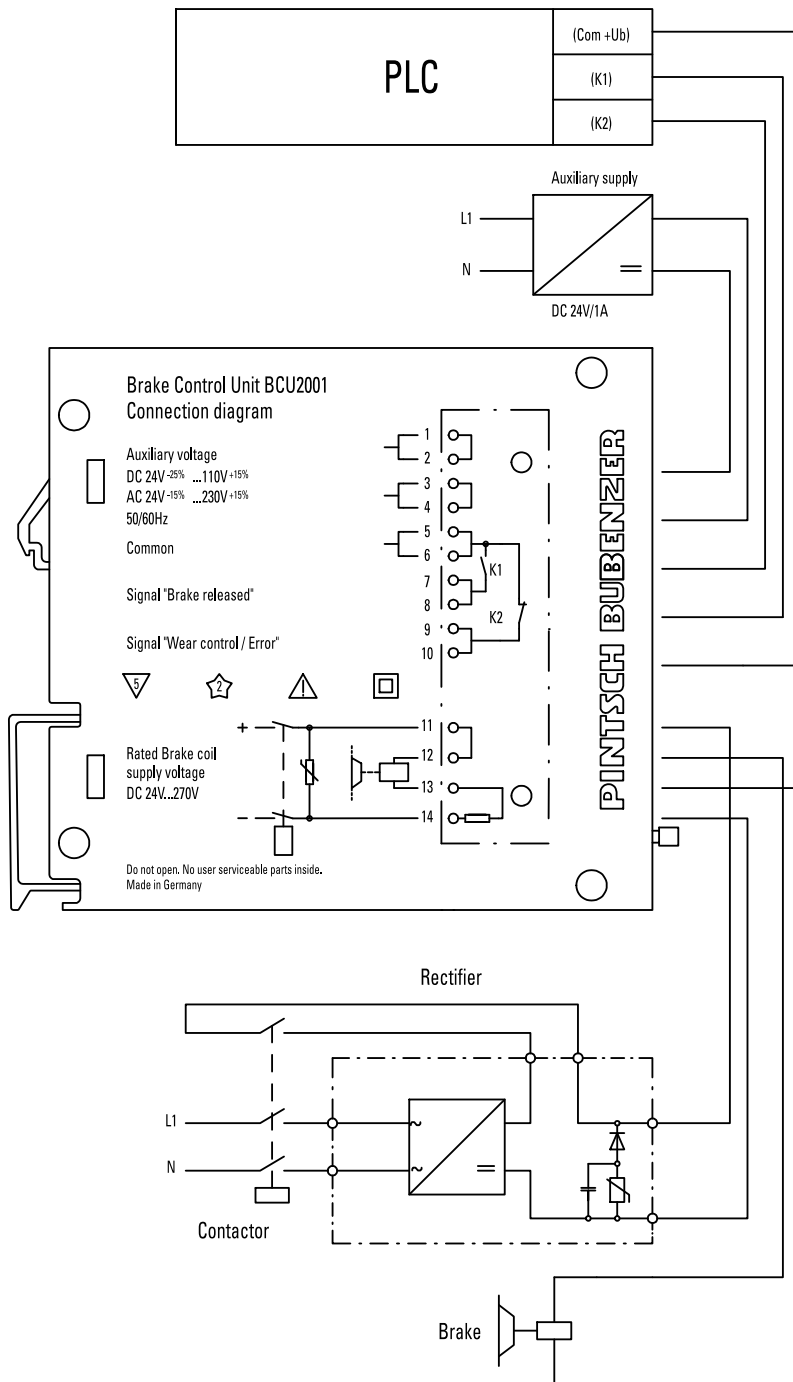

Technical data

Permissible coil voltages:	DC 24V...396V
Ambient temperature:	-40°C ... $+50^{\circ}\text{C}$
Protection class:	IP 20
Permissible auxiliary power supplies:	AC 24 V -15% ... AC 230 V $+15\%$ DC 24 V -25% ... DC 110 V $+15\%$

Brake Control Unit BCMS-4



PINTSCH BUBENZER
is certified according to
DIN EN ISO 9001:2015



Reliable



High Performance



Robust



Easy Maintenance



Compact



Tried and Trusted

Description Brake Control Unit BCMS-4



Main Features

■	Plug and play – minimal configuration and implementation effort
■	No micro- or proximity switches required for the brake (much lower amount of wiring)
■	Components such as contactors, power rectifier, suppressor to be omitted (space and cost savings)
■	Through the use of plug-in terminals a prior installation of the connecting cables is possible (saves time)
■	Normal maintenance intervals are not required on our brakes (extreme reduction of maintenance costs)
■	Due to the 4-channel version up to four spring-loaded brakes can be operated simultaneously
■	Certified safety through professional association
■	In conjunction with a superior safety PLC operation by security classification DIN EN ISO 13849-1 PL d, Cat 3 is possible
■	Internal 2-channel safety logic in redundant design
■	Providing I / O diagnostic outputs for integration into PLC
■	Quick releasing and closing of the brakes
■	Overcurrent trip to protect the brakes
■	Wire break recognition
■	Minimize the power dissipation of the brakes by regulation the holding current
■	Internal menu structure

■	Representation of the status wear
■	User interface RS 232 for connection and intervention in the menu structure
■	Manual operation of the menu structure
■	The operating status and diagnostic messages are be visualized and displayed at the unit itself
■	Optimization of the wear allowance
■	„One solution, one source“

Applications

■	Container cranes
■	Ship winches
■	Automatic racking systems
■	Conveyor belts
■	General electrical drives

Method

The BCMS-4 is a micro-controller-based monitoring and switching device for spring applied brakes of the SFB and KFB series. Through measurement and analysis of current and voltage of the outgoing two-wire lines of the individual brakes wear and switching state of each electromagnetic spring-applied brake can be detected in some distant mounting position. There can be up to four brakes operated and evaluated simultaneously. The operation of the brakes is fundamentally with rapid releasing and closing of the brakes.



Please Note

We supply a detailed operating manual with every order. Nevertheless, we would point out that brakes are only as safe as the servicing and maintenance performed while they are in operation. The guarantee for the correct functioning of our brakes is only valid if the user adheres to the German DIN standard 15434 part 2 (drum and disc brakes, servicing and maintenance in operation), or to comparable standards in his own country.



PINTSCH BUBENZER Service

This includes the verification of the brake selection, if required. A detailed questionnaire is provided for this purpose. Installation and commissioning on-site by PINTSCH BUBENZER service engineers is possible. Drawings as DWG/DXF files for your engineering department are available upon request.

Brake Control Unit BCMS-4

Principal circuit diagram



Rev. 11-11

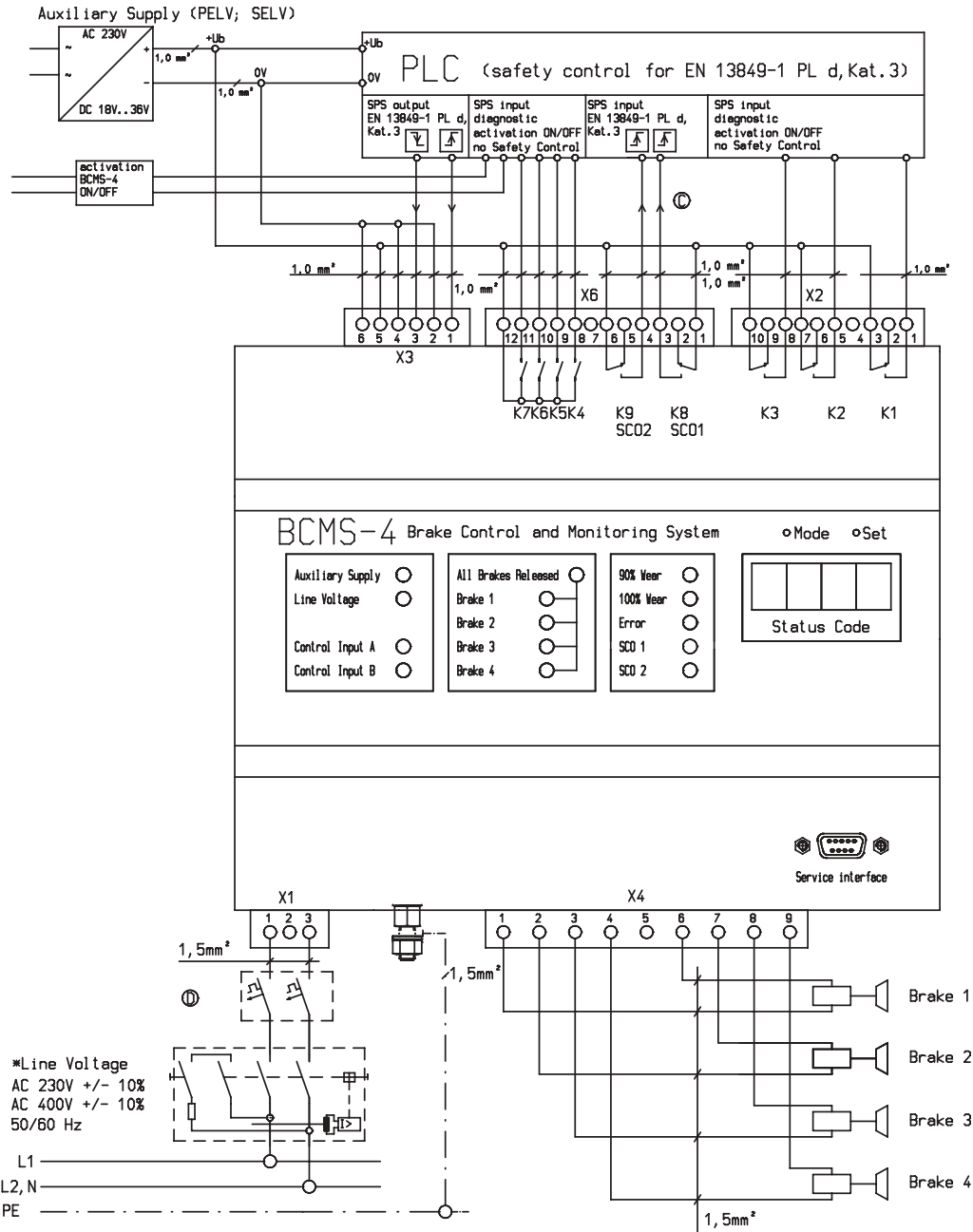

Technical data

Permissible auxiliary power supplies:	AC 230V +/- 10%; 50/60 Hz AC 400V +/- 10%; 50/60 Hz
Ambient temperature:	-30°C +50°C
Protection class:	IP 20
Permissible coil voltages:	110 V DC and 207 V DC
security rating:	DIN EN ISO 13849-1 PL d, Cat 3
PFHD:	1.16 ⁻⁷



2nd edition

PINTSCH BUBENZER GmbH

Friedrichshuettenstr. 1
D-57548 Kirchen-Wehbach
Phone +49 27 41/94 88-0

Huenxer Str. 149
D-46537 Dinslaken
Phone +49 20 64/602-0

www.pintschbubenzler.com