



BRAKE SYSTEMS FOR STEEL MILLS
BRAKING UNLIMITED

Made in Germany



© 2018 PINTSCH BUBENZER

www.pintschbubenzler.com

Content

Thruster Disc Brakes	_____	A7 - A12
Hydraulic Disc Brakes	_____	B1 - B5
Electromagnetic Disc Brakes	_____	C1 - C9, CX1 - CX15, C21 - C26
Drum Brakes	_____	E1 - E3, E15 - E16
Couplings, Hubs, Discs	_____	F1 - F8, F13 - F16
Monitoring Systems, Control Systems	_____	G1 - G9, G13 - G16
Buffers	_____	I1 - I9

Thruster Disc Brakes SB 8 Series

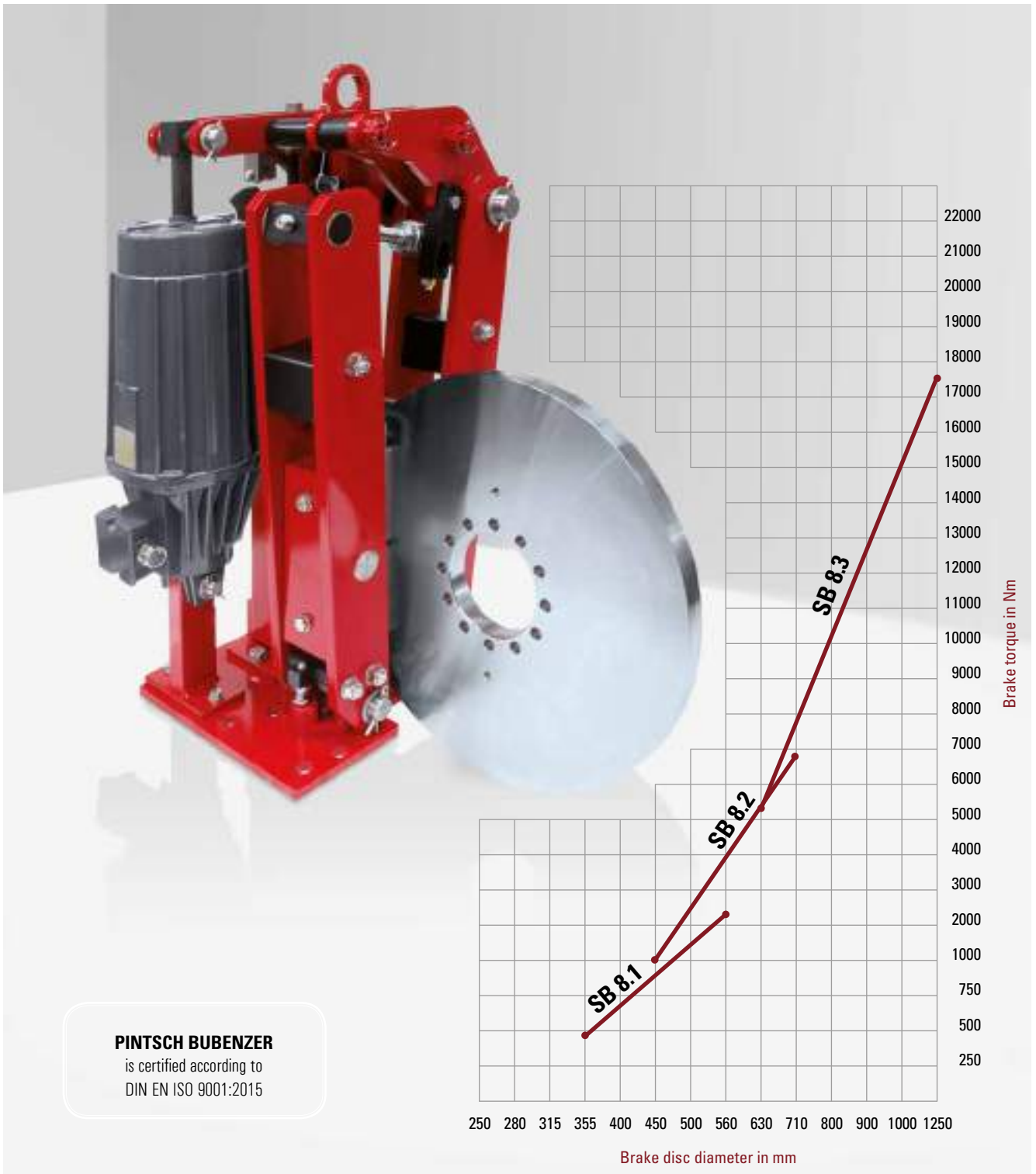

PINTSCH BUBENZER
is certified according to
DIN EN ISO 9001:2015



Reliable



Compact Design



Robust Construction



Easy Maintenance

Description SB 8



Main Features - Steel Mill Execution

Very compact dimensions
Thrusters for high ambient temperatures in steel mills
Wear resistant linings
Adjustable, enclosed brake spring with torque scale
Stainless steel pins and spindles
Maintenance free bushings in all hinge points
Right or Left hand design

Options

Heavy-duty designed automatic wear compensator (dust-proof)
Heat resistant wiring of limit switches
Limit switch release control (special execution)
Limit switch wear control (special execution)
Limit switch manual release (special execution)
Manual release lever with or without stop
Monitoring systems (e.g. VSR)
Brake disc with hub or coupling

Ordering Example

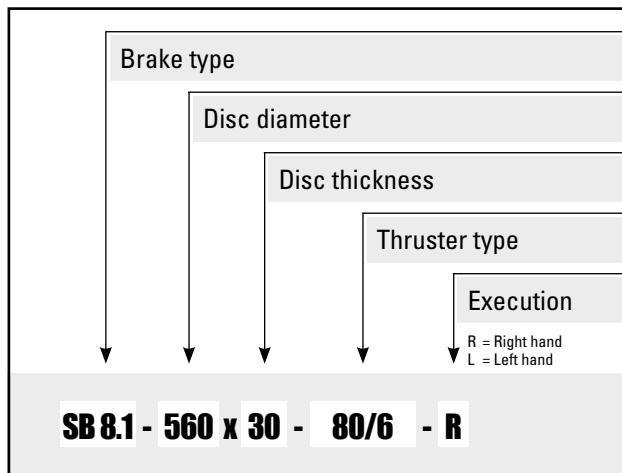

Thrusters, Technical Data

Thruster Type	Power (W)	Curr. (A) at 400 V	Weight (kg)
Ed 30/5	200	0,5	14
Ed 50/6	210	0,5	23
Ed 80/6	330	1,2	24
Ed 121/6	330	1,2	39
Ed 201/6	450	1,3	39
Ed 301/6	550	1,4	40

Data supplied by thruster manufacturer, please take higher start current into consideration, fuses to be minimum 2A



Please Note

We supply a detailed operating manual with every order. Nevertheless, we would point out that brakes are only as safe as the servicing and maintenance performed while they are in operation. The guarantee for the correct functioning of our brakes is therefore only valid if the user adheres to the German DIN standard 15434 part 2 (drum and disc brakes, servicing and maintenance in operation), or to comparable standards in his own country.



PINTSCH BUBENZER Service

This includes the verification of the brake selection, if required. A detailed questionnaire is provided for this purpose. Installation and commissioning on site is possible by PINTSCH BUBENZER service engineers. Drawings as DWG/DXF files for your engineering department are available upon request.

Disc Brake SB 8.1

Dimensions and technical data



Rev. 03-18
MB-001637 b

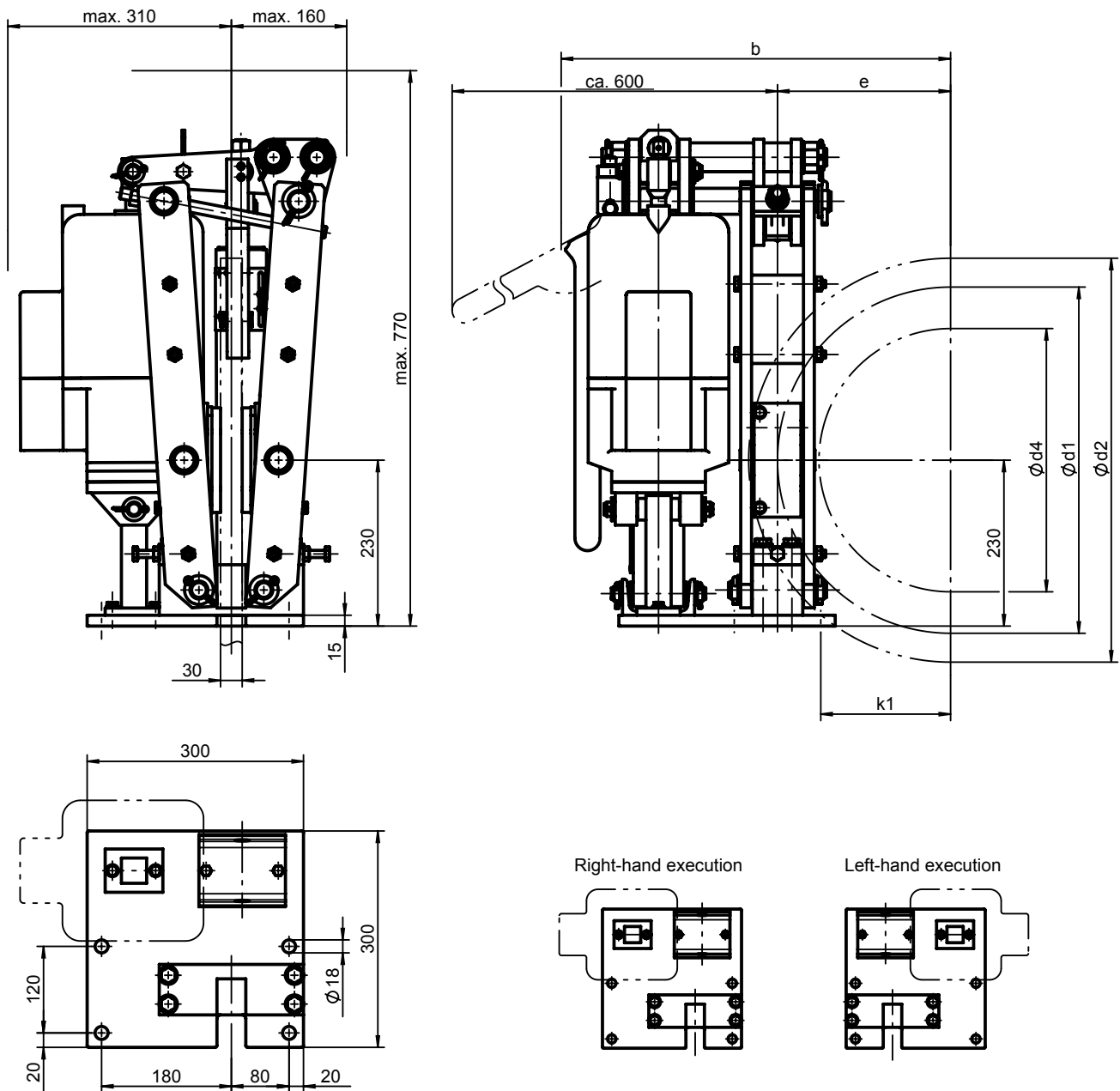

All dimensions in mm
Alterations reserved without notice

*) Average static friction factor of standard material combination

For crane brake layout use safety factors documented in the FEM 1.001, Section 1

The friction coefficient is subject to fluctuations depending on operational-, material- and ambient-conditions! This must be considered during the selection!

Weight without thruster: ca. 83 kg			Thruster type			Ed 30/5 (weight: 14 kg)			Ed 50/6 (weight: 23 kg) Ed 50/12 (weight: 26 kg)			Ed 80/6 (weight: 24 kg) Ed 80/12 (weight: 27 kg)		
Disc-Ø d2	Friction-Ø d1	Max. hub-Ø d4	Contact force in N			4300			7700			11800		
			b _{max.}	e	k ₁	*M _{Bmax.} (Nm) at μ = 0,4	*M _{Bmin.} (Nm) at μ = 0,4	*M _{Bmin.} (% from M _{Bmax.})	*M _{Bmax.} (Nm) at μ = 0,4	*M _{Bmin.} (Nm) at μ = 0,4	*M _{Bmin.} (% from M _{Bmax.})	*M _{Bmax.} (Nm) at μ = 0,4	*M _{Bmin.} (Nm) at μ = 0,4	*M _{Bmin.} (% from M _{Bmax.})
355	275	160	438	137,5	77,5	475	238	50	845	423	50	1300	650	50
400	320	205	460	160	100	550	275	50	985	493	50	1510	755	50
450	370	255	485	185	125	635	318	50	1140	570	50	1745	873	50
500	420	305	510	210	150	720	360	50	1295	648	50	1980	990	50
560	480	365	540	240	180	825	413	50	1480	740	50	2265	1133	50

Disc Brake SB 8.2

Dimensions and technical data



Rev. 03-18
MB-001638 a

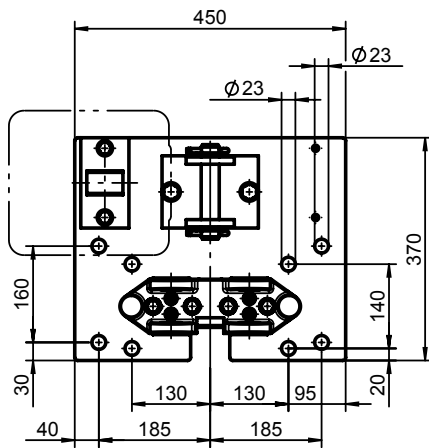
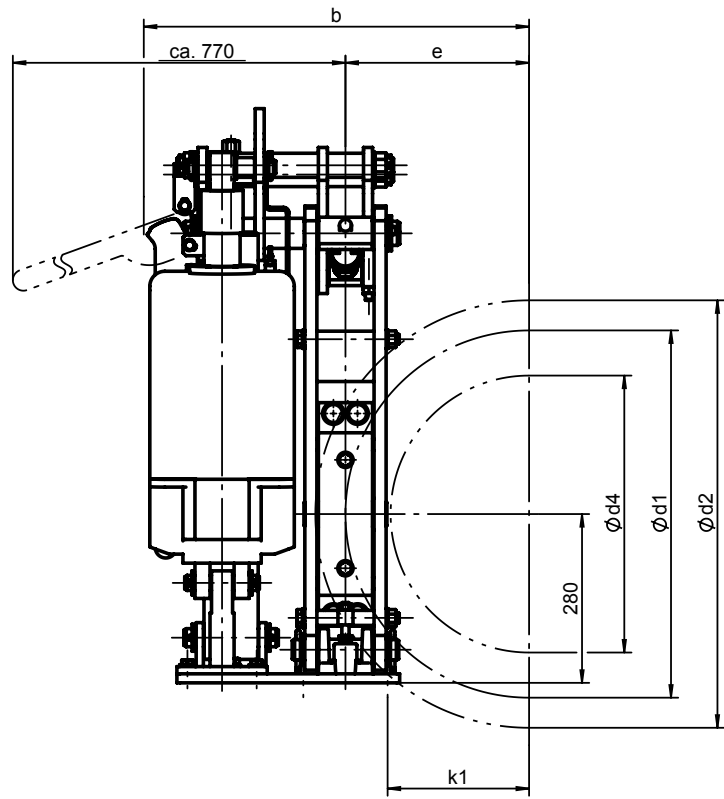
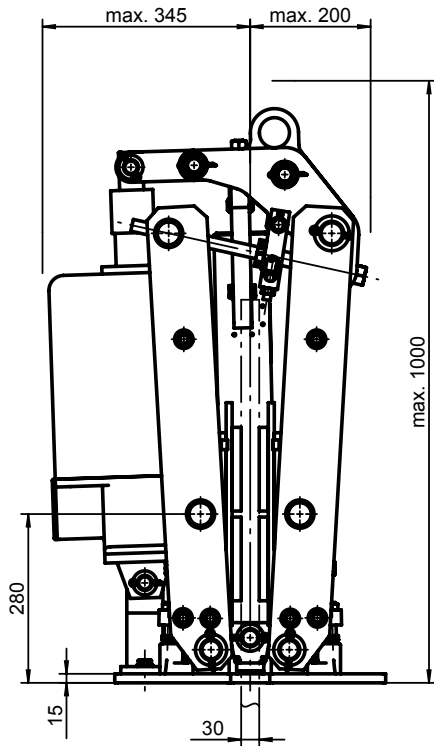

Right-hand execution

Left-hand execution

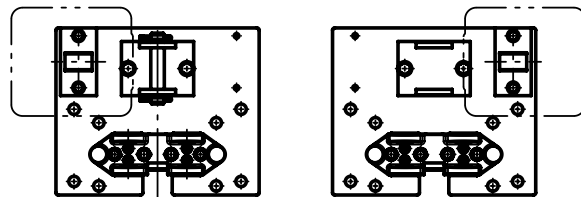

All dimensions in mm
Alterations reserved without notice

*) Average static friction factor of standard material combination

For crane brake layout use safety factors documented in the FEM 1.001, Section 1

The friction coefficient is subject to fluctuations depending on operational-, material- and ambient-conditions! This must be considered during the selection!

Weight without thruster: ca. 180 kg			Thruster type			Ed 50/6 (weight: 23 kg) Ed 50/12 (weight: 26 kg)			Ed 80/6 (weight: 24 kg) Ed 80/12 (weight: 27 kg)			Ed 121/6 (weight: 39 kg) Ed 121/12 (weight: 39 kg)			Ed 201/6 (weight: 39 kg) Ed 201/12 (weight: 39 kg)		
Disc-Ø d2	Friction-Ø d1	Max. hub-Ø d4	Contact force in N			7255			11270			18195			28030		
			b _{max.}	e	k ₁	*M _{Brmax.} (Nm) at μ = 0,4	*M _{Brmin.} (Nm) at μ = 0,4	*M _{Brmin.} (% from M _{Brmax.})	*M _{Brmax.} (Nm) at μ = 0,4	*M _{Brmin.} (Nm) at μ = 0,4	*M _{Brmin.} (% from M _{Brmax.})	*M _{Brmax.} (Nm) at μ = 0,4	*M _{Brmin.} (Nm) at μ = 0,4	*M _{Brmin.} (% from M _{Brmax.})	*M _{Brmax.} (Nm) at μ = 0,4	*M _{Brmin.} (Nm) at μ = 0,4	*M _{Brmin.} (% from M _{Brmax.})
450	350	200	510	175	105	1015	660	65	1580	869	55	2545	1273	50	3925	1963	50
500	400	250	535	200	130	1160	754	65	1805	993	55	2910	1455	50	4485	2243	50
560	460	310	565	230	170	1335	868	65	2075	1141	55	3350	1675	50	5160	2580	50
630	530	380	600	265	195	1540	1001	65	2390	1315	55	3855	1928	50	5940	2970	50
710	610	460	640	305	235	1770	1151	65	2750	1513	55	4440	2220	50	6840	3420	50

Disc Brake SB 8.3

Dimensions and technical data



Rev. 03-18
MB-001639 a

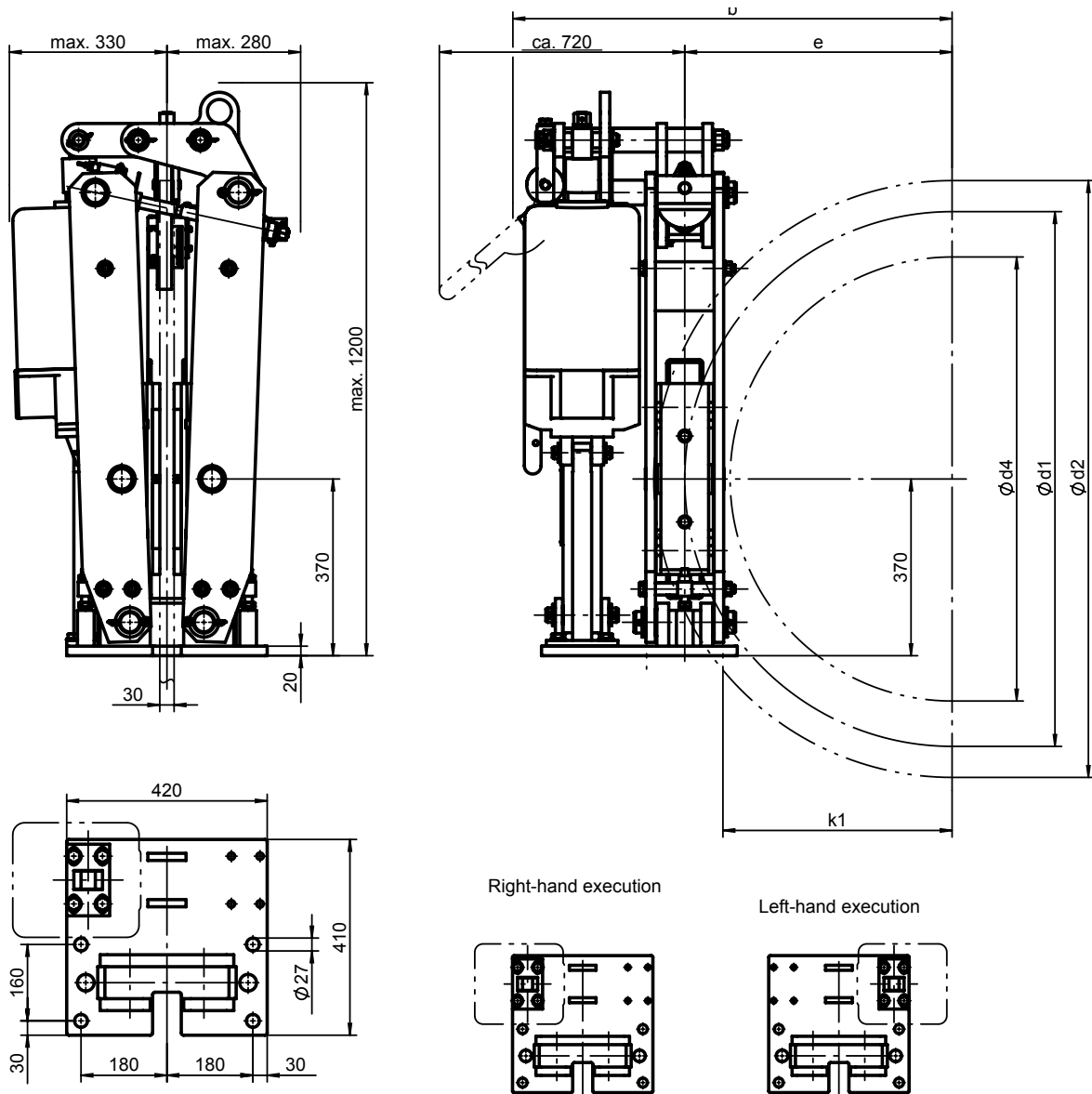

All dimensions in mm
Alterations reserved without notice

*) Average static friction factor of standard material combination

For crane brake layout use safety factors documented in the FEM 1.001, Section 1

The friction coefficient is subject to fluctuations depending on operational-, material- and ambient-conditions! This must be considered during the selection!

Weight without thruster: ca. 290 kg			Thruster type			Ed 201/6 (weight: 39 kg) Ed 201/12 (weight: 39 kg)			Ed 301/6 (weight: 40 kg) Ed 301/12 (weight: 40 kg)		
			Contact force in N			25735			39150		
Disc-Ø d2	Friction-Ø d1	Max. hub-Ø d4	b _{max.}	e	k ₁	*M _{Brmax.} (Nm) at μ = 0,4	*M _{Brmin.} (Nm) at μ = 0,4	*M _{Brmin.} (% from M _{Brmax.})	*M _{Brmax.} (Nm) at μ = 0,4	*M _{Brmin.} (Nm) at μ = 0,4	*M _{Brmin.} (% from M _{Brmax.})
630	500	310	610	250	170	5145	2573	50	7830	3915	50
710	580	390	650	290	210	5970	2985	50	9085	4543	50
800	670	480	695	335	255	6895	3448	50	10490	5245	50
900	770	580	745	385	305	7925	3963	50	12060	6030	50
1000	870	680	795	435	355	8955	4478	50	13625	6813	50
1250	1120	930	920	560	480	11530	5765	50	17540	8770	50

Hydraulic Caliper Disc Brakes SF Series

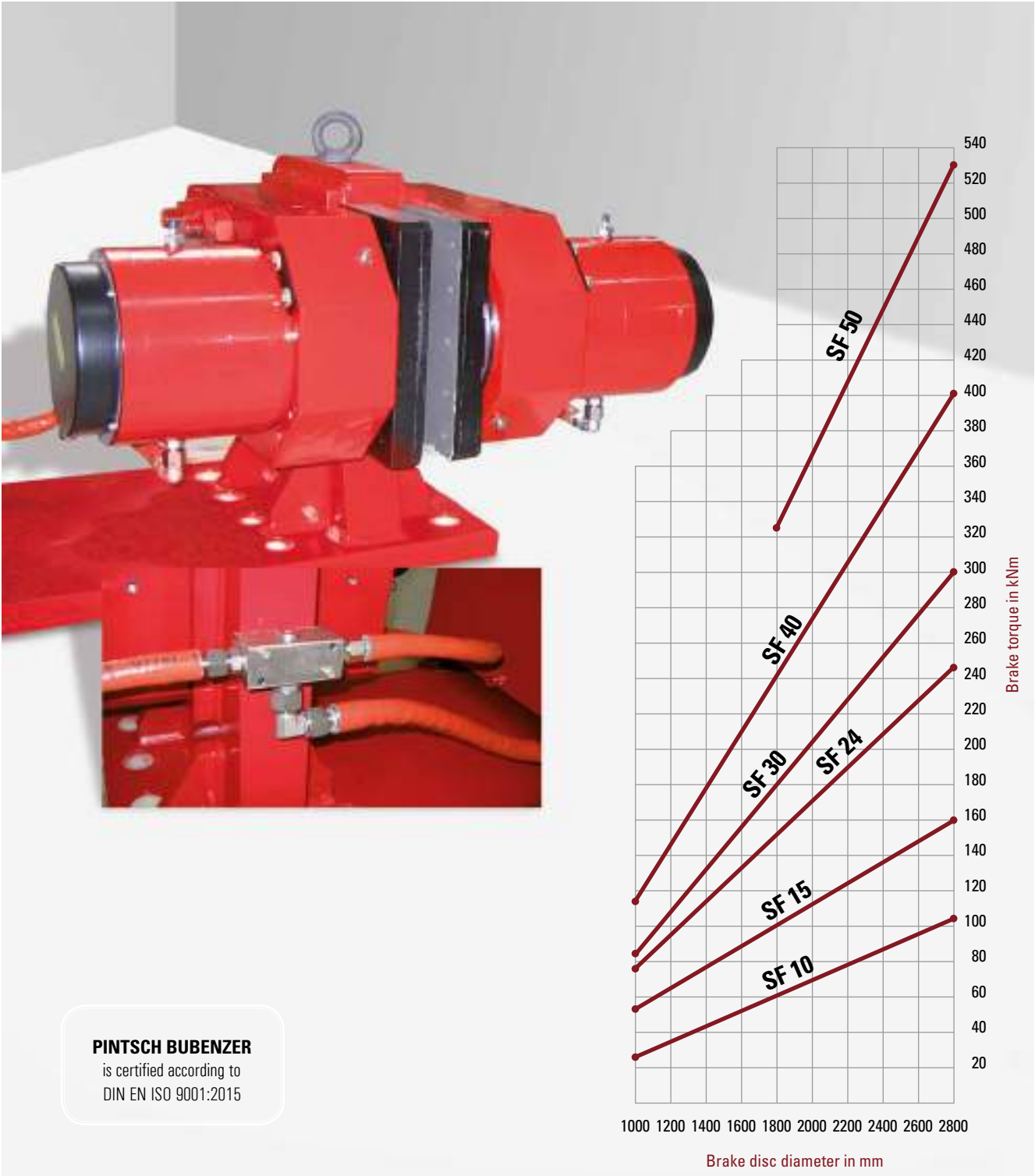

PINTSCH BUBENZER
is certified according to
DIN EN ISO 9001:2015



Reliable



High Performance



Robust Design



Easy Maintenance

Description SF



Main Features - Steel Mill Execution

Two identical caliper halves, ready for operation, with spring packs set to nominal force and limit switch for release control (heat resistant)
Up to 2 mm airgap between linings and brake disc
Easy, manual pad wear compensation
Organic, non-asbestos linings
Special seals for flame-proof liquids
Viton seals

Hydraulic power unit - Steel Mill Execution

Dead man's circuit
Stainless steel tank
Non flammable oil
Oil temperature switch
Automatic emergency release system
Stainless steel cover

Options

Heat resistant wiring of limit switches
Limit switch wear control (special execution)
Heat resistant piping
Completely piped supports for one or more calipers
Hydraulic power units
Cleaning pad

Applications

The high capacity of these brakes makes them particularly suitable as secondary emergency brakes on main hoists (ladle cranes)
Other applications are possible in material handling, requiring power and compact design in either direction of rotation, particularly in replacing band brakes
Use of the brakes for applications with high duty cycles should be specifically indicated during technical selection procedure

Operating Restrictions

Brakes of this range are tested both mechanically and hydraulically and are set to nominal force. This setting can only be changed by the manufacturer. Operating conditions other than described in this brochure require the manufacturer's approval and may influence the function of the caliper and its components



Please Note

We supply a detailed operating manual with every order. Nevertheless, we would point out that brakes are only as safe as the servicing and maintenance performed while they are in operation. The guarantee for the correct functioning of our brakes is therefore only valid if the user adheres to the German DIN standard 15434 part 2 (drum and disc brakes, servicing and maintenance in operation), or to comparable standards in his own country.



PINTSCH BUBENZER Service

This includes the verification of the brake selection, if required. A detailed questionnaire is provided for this purpose. Installation and commissioning on site is possible by PINTSCH BUBENZER service engineers. Drawings as DWG/DXF files for your engineering department are available upon request.

Disc Brake SF

Dimensions and technical data



Rev. 04-18

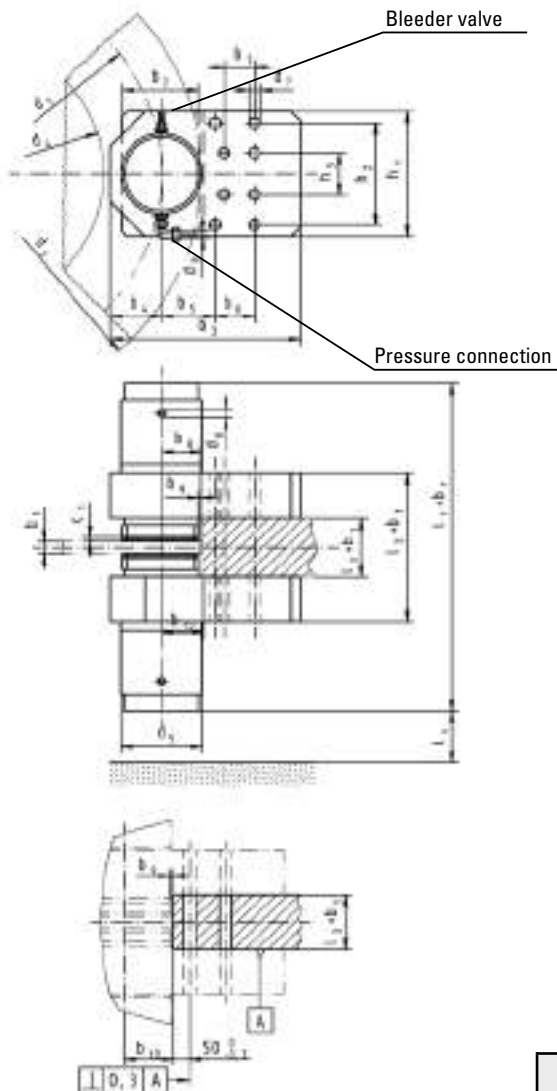

*) Average friction factor of standard material combination

All dimensions in mm. Alterations reserved without notice.

Brake torque M_{Br} in Nm = F_A (kN) x μ x d_1 (mm)

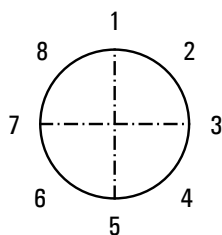

Please indicate required mounting position.

Type SF	10	15	24	30	40
b ₂	165	165	195	280	300
b ₃	410	410	480	640	720
b ₄	110	110	130	155	175
b ₅	115	115	130	200	220
b ₆	85	85	100	110	125
b ₇	60	60	70	110	125
b ₈	85	85	100	140	160
b ₉	5	5	5	5	10
b ₁₀	90	90	105	150	170
c ₁	10	10	10	10	10
d ₅	175	175	225	280	310
d ₆	G1/2"	G1/2"	G1/2"	G1/2"	G1/2"
d ₇	25	25	31	38	50
d ₈	12	12	12	12	12
h ₁	270	270	300	400	480
h ₂	220	220	230	300	375
h ₃	90	90	70	100	125
l ₁	655	680	815	945	985
l ₂	300	300	350	402	506
l ₃	100	100	110	130	110
l _{4min}	110	110	130	180	200
Bolt \emptyset	M24	M24	M30	M36	M48
Bolt material	10.9	10.9	10.9	10.9	10.9
Tighten. torque, Nm	1050	1050	2100	3500	6400
Contact force F_A kN	100	150	240	300	400
Op. pressure bar	140	180	180	210	210
Max. pressure bar	200	200	200	240	240
Release stroke mm	2	2	2	2	2
Oil volume l	0,023	0,023	0,035	0,050	0,052
Pad surface cm ²	398	398	533	1050	1360
Theor. friction μ^*	0,40	0,40	0,40	0,40	0,40
Weight (kg)	200	210	368	750	1180

Data per caliper half

Brake disc data					
	SF10	SF15	SF24	SF30	SF40
d ₁ =	d ₂ -170 mm	d ₂ -170 mm	d ₂ -200 mm	d ₂ -290 mm	d ₂ -320 mm
d ₄ =	d ₂ -420 mm	d ₂ -420 mm	d ₂ -490 mm	d ₂ -620 mm	d ₂ -700 mm

d₂ = Brake disc diameter in mm
d₁ = Friction diameter in mm
d₄ = Max. permissible drum or hub diameter in mm
b₁ = Disc thickness in mm (min. 30)

Disc Brake SF 50

Dimensions and technical data



Rev. 03-18
MB-001011 c

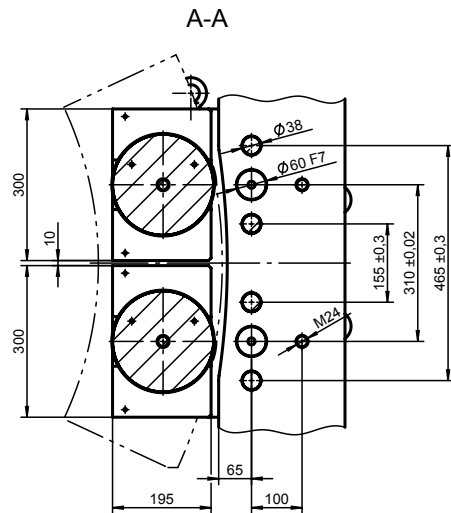
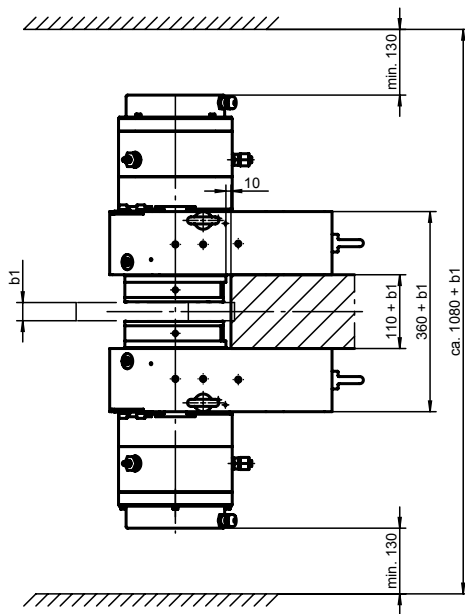
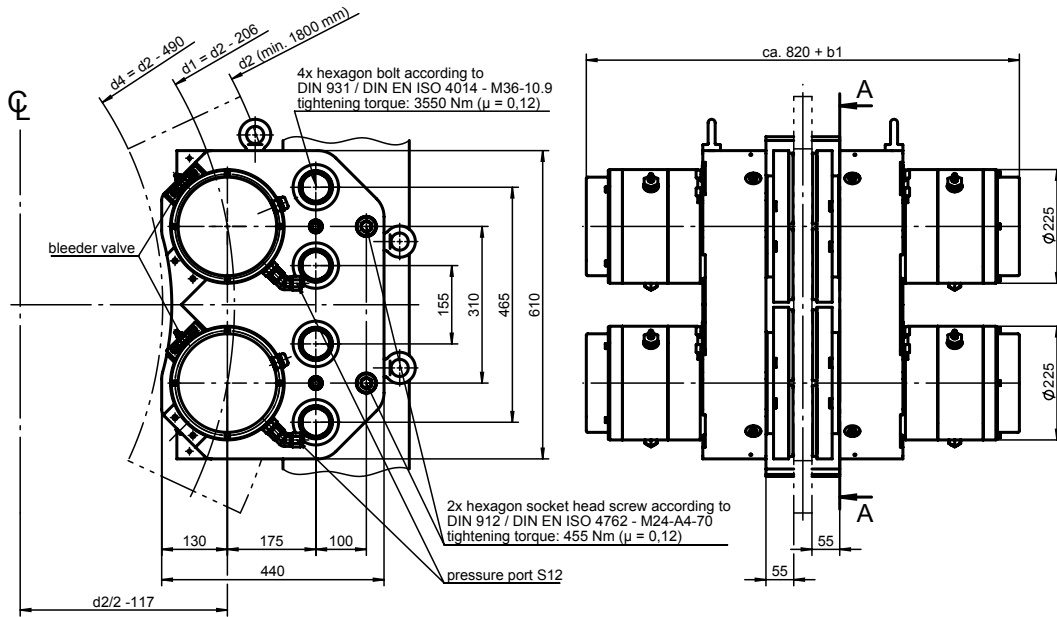

Brake Torque M_{Br} in Nm = F_A (kN) x μ x d1 (mm)

*) Theor. friction factor of standard material combination

All dimensions in mm
Alterations reserved without notice

Type SF 50			
Data per caliper half	Contact force F_A	kN	510
	Operating pressure p	bar	200
	Max. pressure $p_{max.}$	bar	220
	Release stroke	mm	2
	Oil volume	l	0,07
	Pad surface	cm ²	1040
	Theor. friction factor	μ^*	0,40
	Weight (without bracket)	kg	ca. 730

d_2 = Brake disc diameter in mm
 d_1 = Friction diameter in mm
 d_4 = Max. permissible drum or hub diameter in mm
 b_1 = Brake disc thickness in mm (min. 30)

Disc Brake SF

Hydraulic power unit for one and more calipers (example)



Rev. 03-09

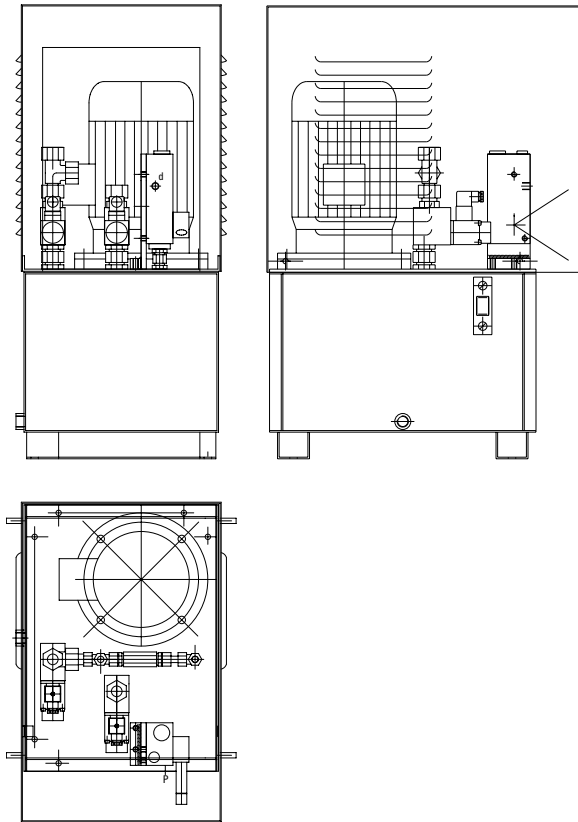

Example:	
Standard configuration	
up to 8	SF10/SF15
up to 4	SF24
Motor:	4 kW
Pump:	12,3 l/min
Pressure:	210 bar
Tank:	40 l
Weight:	115 kg

The flow diagram shows the general arrangement of the hydraulic power unit, including handpump and dead man circuit for emergency manual release of the brakes.

The two solenoid valves are switched in parallel (redundancy). After the nominal pressure is reached, the idler valve switches into idle running.

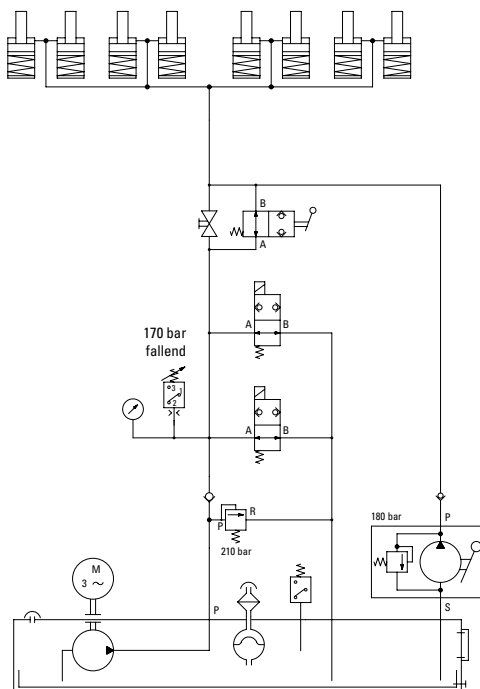

All dimensions in mm
Alterations reserved without notice



With every order we supply a complete hydraulic and electric diagram according to the order specification.

Piping Samples

Disc brakes SF and BSC



Rev. 09-02

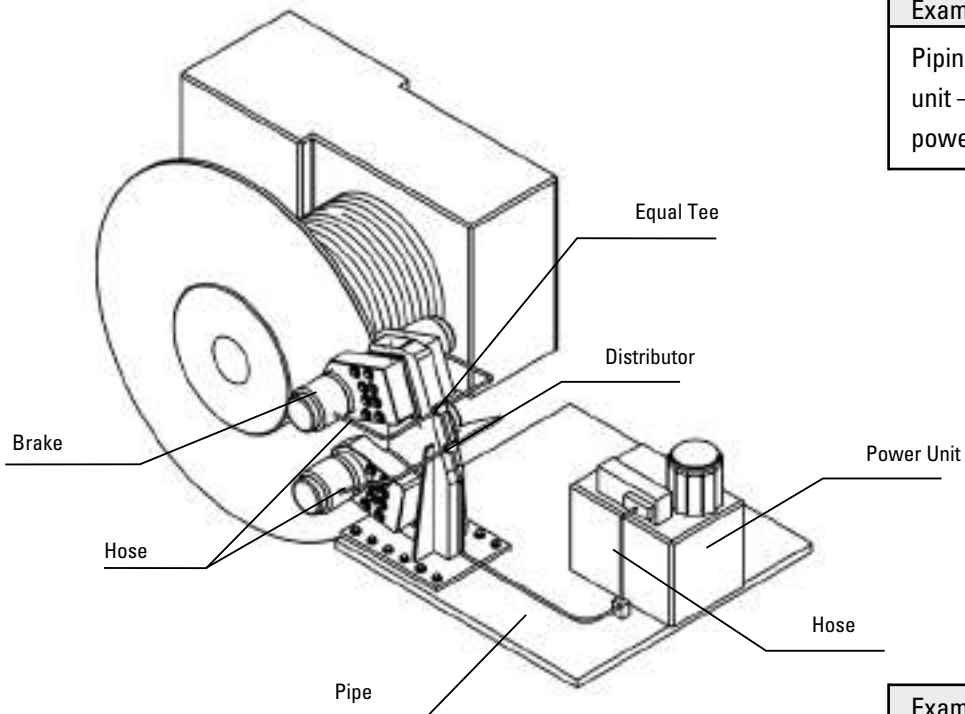

Example:

Piping of one brake unit – one hydraulic power unit

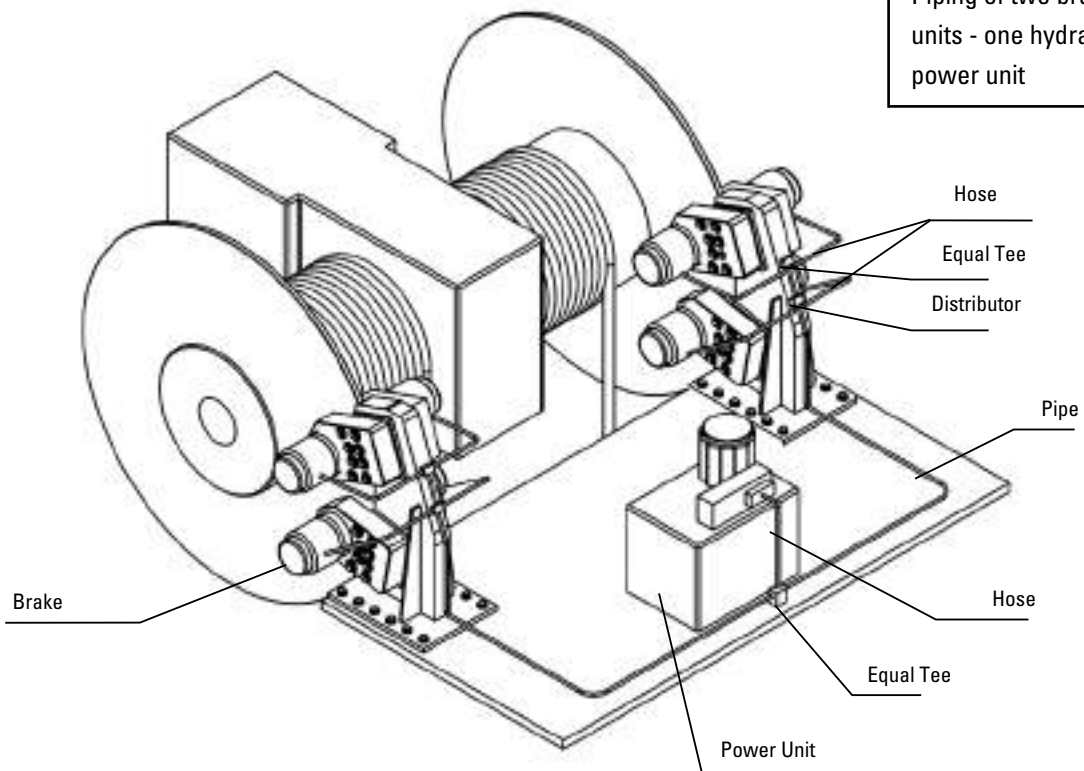

Example:

Piping of two brake units - one hydraulic power unit



Attention: For operating two brake units with one power unit please note, that the power unit should be installed between the brakes in the centre to achieve almost equal pipe length on both sides (equal apply time of brakes).

Spring Set Brakes SFB Series



PINTSCH BUBENZER
is certified according to
DIN EN ISO 9001:2015



Reliable



High Performance



Robust



Easy Maintenance



Compact



Tried and Trusted

Description SFB Series



Main Features

Spring applied safety brake
Electromechanically released
Protection-class IP67
Double wear reserve by single air gap adjustment
High work capacity
High wear resistance because of high abrasion resistance
Functional without cover
Emergency release screws

Applications

Gantry, trolley and hoisting applications
Electrical drives for ship winches and deck machinery
Jack up systems at offshore systems
Dynamic and static use at general industrial applications

Certificates

ABS, DNV, LR, GL, RMROS, BV

Options

Special brake torque:
Lower brake torque = type SFB
Higher brake torque = type SFB-SH
Holding brake torques available on request
Micro- or proximity switches:
• Monitoring the function on/off
• Maximum air gap (wear-monitoring)
Lateral junction box
Tacho preparation with all mounting parts
Cover bore
Shaft sealing
Special voltage
Anti condensation heater
Radial cable outlet
Special flange

Electrical equipment

One-way, bridge and switching rectifier
Protective element
Brake control unit = BCU 2001
Brake control and monitoring system = BCMS-4



Please Note

We supply a detailed operating manual with every order. Nevertheless, we would point out that brakes are only as safe as the servicing and maintenance performed while they are in operation. The guarantee for the correct functioning of our brakes is only valid if the user adheres to the German DIN standard 15434 part 2 (drum and disc brakes, servicing and maintenance in operation), or to comparable standards in his own country.



PINTSCH BUBENZER Service

This includes the verification of the brake selection, if required. A detailed questionnaire is provided for this purpose. Installation and commissioning on-site by PINTSCH BUBENZER service engineers is possible. Drawings as DWG/DXF files for your engineering department are available upon request.

Spring Set Brake SFB

Electromagnetic Two Disc, Spring Set Brake



Rev. 05-08

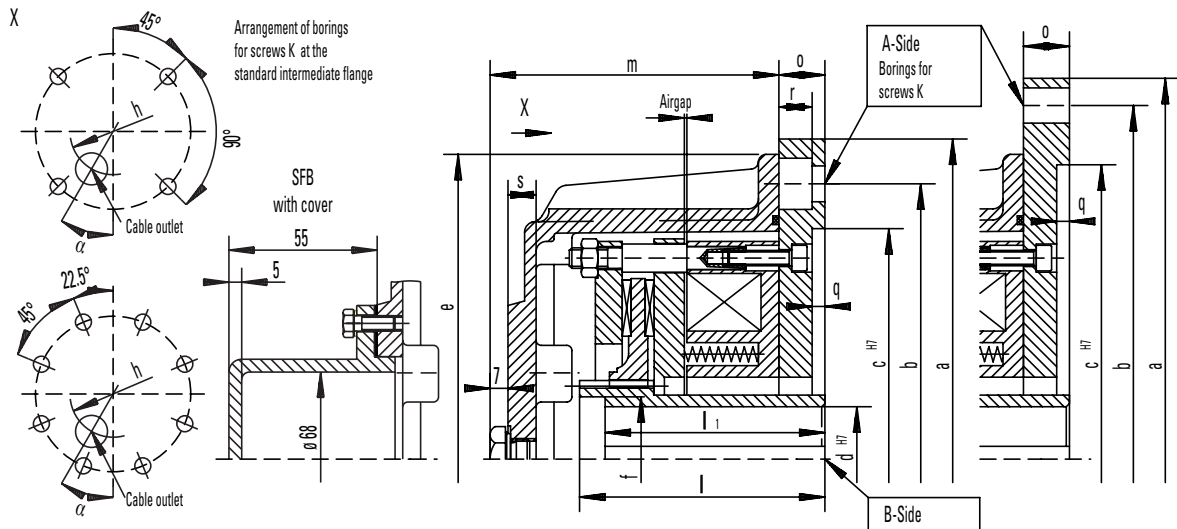

Keyways for keys acc. to DIN6885 Bl.1, width accuracy P9. Protection IP67

Alterations reserved without notice

Brake size		SFB 6.3	SFB 10	SFB 16	SFB 25	SFB 40	SFB 63	SFB 100	SFB 160	SFB 250			
Brake torque M2 dynamic acc. to DIN VDE 0580	Nm	63	100	160	250	400	630	1000	1600	2500			
		54	80	130	210	330	520	830	1300	2100			
		45	63	100	180	260	400	660	1050	1650			
Mass moment of inertia	kgm ²	0.0017	0.0037	0.0048	0.0068	0.0175	0.036	0.050	0.128	0.140			
Mass (weight)	kg	19	28	42	55	74	106	168	242	306			
max. speed	min ⁻¹	6000	6000	6000	5500	4700	4000	3600	3200	2800			
Coil b. 20° C	Nominal voltage	V DC	110	110	110	110	110	110	110	110			
	Nominal power	W	99	128	158	196	220	307	344	435			
	Nominal current	A	0.90	1.16	1.44	1.78	2.0	2.79	3.13	3.95			
Air gap, brake OFF		min. mm	0.3	0.3	0.3	0.4	0.4	0.6	0.4	0.4			
		max. mm	0.9	1.2	1.2	1.3	1.4	1.8	2.3	2.5			
Diameter mm	B-Side	d Rough boring	26	26	36	36	36	36	36	46	46		
		d ^{H7} Preferential boring	28	28	38	38	48	60	60	65	65		
			32	32	42	42	55	65	65	70	70		
			38	38	48	48	60	75	75	75	75		
					55	55				80	80		
	d ^{H7} maximal	40	40	55	55	60	75	75	110	110			
Length mm	e	238	260	280	318	400	440	446	540	556			
	f						95	95	128	128			
	h	150	180	202	214	244	292	330	394	440			
	l	96	96	117	117	142	148	148	191	191			
	l ¹	96	96	117	117	142	142	142	171	171			
	m	115	118	137	143	169	171	183	211	232			
s	11	11	11	12	14	15	15	15	15				
A	α °	15	15	30	22.5	30	30	30	30	45			
Suitable standard Intermediate flange		A250	A300	A300-1	A350	A400-1	A450-1	A450-1	A550-1	A660			
		A300	A350	A350	A400	A450	A550	A550	A660	A800			
				A400	A450	A550	A660	A660	A800				
				A450									
Dimensions of standard intermediate flanges													
Standard intermediate flange		A250	A300	A300-1	A350	A400	A400-1	A450	A450-1	A550	A550-1	A660	A800
Diameter mm	a	250	300	300	350	400	400	450	450	550	550	660	800
	b	215	265	265	300	350	350	400	400	500	500	600	740
	c ^{H7}	180	230	230	250	300	300	350	350	450	450	550	680
Length mm	o	18	18	18	20	22	22	24	24	24	24	30	30
	q	5	5	5	6	6	6	6	6	6	6	7	7
	r	13		13			17.5		17.5		17.5		
	Screws	k	4xM12	4xM12	4xM12	4xM16	4xM16	4xM16	4xM12	8xM16	8xM16	8xM16	8xM20

Spring Set Brake SFB

Electromagnetic Two Disc, Spring Set Brake



Rev. 05-08

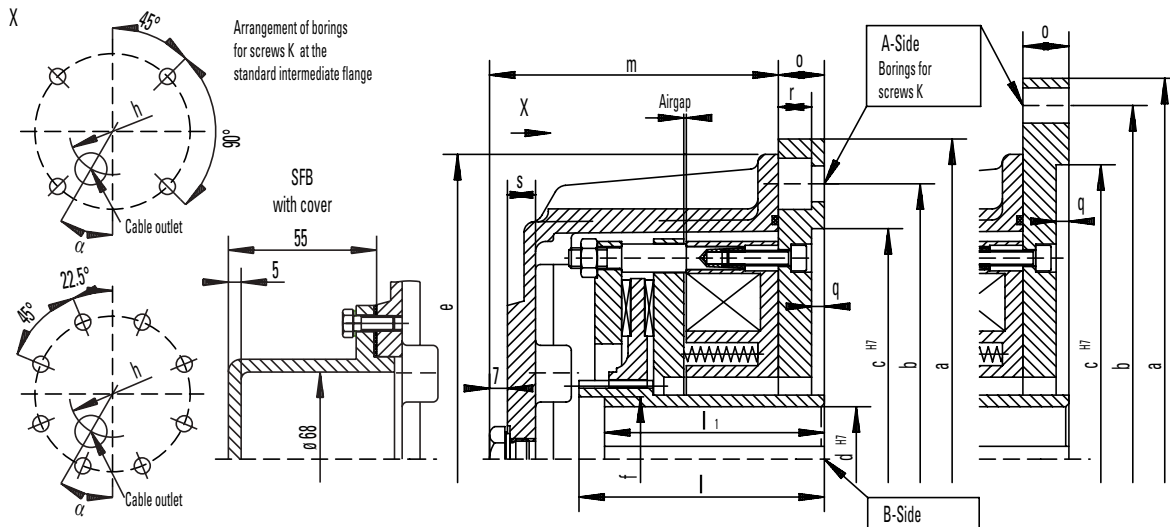

Brake size		SFB 400	SFB 630	SFB 1000	
Brake torque M2 dynamic acc. to DIN VDE 0580	Nm	4000	6300	10000	
		3350	5250	8500	
		2650	4200	7000	
Mass moment of inertia	kgm ²	0.325	0.375	1.007	
Mass (weight)	kg	357	500	750	
max. speed	min ⁻¹	2500	2200	2000	
Coil b. 20° C	Nominal voltage	V DC	110	110	110
	Nominal power	W	553	671	980
	Nominal current	A	5.03	6.10	8.91
Air gap, brake OFF		min. mm	0.4	0.7	0.7
		max. mm	2.5	2.8	3.1
Diameter mm	B-Side	d Rough boring	46	58	68
		d ^{H7} Preferential boring	65	100	125
			70		
			75		
			80		
			90		
d ^{H7} maximal	110	125	140		
Length mm	e	660	700	795	
	f	128	140	155	
	h	520	570	620	
	l	191	237	282	
	l ¹	171	210	255	
	m	272	310	360	
	s	15	15	15	
A	α°	30	30	30	
Suitable standard intermediate flange		A660-1	A800	A800-1	
		A800			
		Dimensions of standard intermediate flange			
Standard intermediate flange		A660-1	A800	A800-1	
Diameter mm	a	660	800	800	
	b	600	740	740	
	c ^{H7}	550	680	680	
Length mm	o	30	30	30	
	q	7	7	7	
	r	21.5		21.5	
Screws k		8xM20	8xM20	8xM20	

Keyways for keys acc. to DIN6885 Bl.1, width accuracy P9. Protection IP67

Alterations reserved without notice

Spring Set Brake SFB-SH

Electromagnetic Two Disc, Spring Set Brake
Increased brake torque



Rev. 05-08

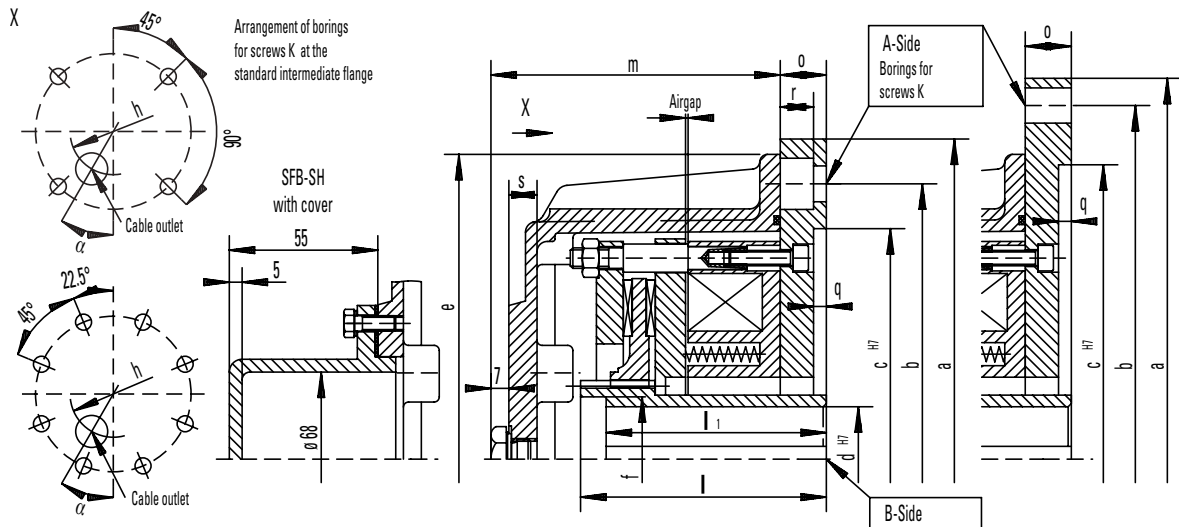

Keyways for keys acc. to DIN6885 Bl.1,
width accuracy P9. Protection IP67

Alterations reserved without notice

Brake size		SFB 6.3-SH	SFB 10-SH	SFB 16-SH	SFB 25-SH	SFB 40-SH	SFB 63-SH	SFB 100-SH	SFB 160-SH	SFB 250-SH			
Brake torque M2 dynamic acc. to DIN VDE 0580	Nm	80	130	210	350	550	800	1300	2100	3300			
		75	120	190	310	490	750	1200	1900	3000			
		69	110	180	275	440	690	1100	1750	2750			
Mass moment of inertia	kgm ²	0.0017	0.0037	0.0048	0.0068	0.0175	0.036	0.050	0.128	0.140			
Mass (weight)	kg	19	28	42	55	74	106	168	242	306			
max. speed	min ⁻¹	6000	6000	6000	5500	4700	4000	3600	3200	2800			
Coil b. 20° C	Nominal voltage	V DC	110	110	110	110	110	110	110	110			
	Nominal power	W	99	128	158	196	220	307	344	435	495		
	Nominal current	A	0.90	1.16	1.44	1.78	2.0	2.79	3.13	3.95	4.50		
Air gap, brake OFF		min. mm	0.3	0.3	0.3	0.4	0.4	0.6	0.4	0.4			
		max. mm	0.9	1.2	1.2	1.3	1.4	1.8	1.8	2.3	2.5		
Diameter mm	B-Side	d Rough boring	26	26	36	36	36	36	36	46	46		
		d H7 Preferential boring	28	28	38	38	48	60	60	65	65		
			32	32	42	42	55	65	65	70	70		
			38	38	48	48	60	75	75	75	75		
					55	55				80	80		
	d H7 maximal	40	40	55	55	60	75	75	110	110			
Length mm	e	238	260	280	318	400	440	446	540	556			
	f						95	95	128	128			
	h	150	180	202	214	244	292	330	394	440			
	l	96	96	117	117	142	148	148	191	191			
	l ¹	96	96	117	117	142	142	142	171	171			
	m	115	118	137	143	169	171	183	211	232			
s	11	11	11	12	14	15	15	15	15				
A	α °	15	15	30	22.5	30	30	30	30	45			
Suitable standard intermediate flange		A250	A300	A300-1	A350	A400-1	A450-1	A450-1	A550-1	A660			
		A300	A350	A350	A400	A450	A550	A550	A660	A800			
				A400	A450	A550	A660	A660	A800				
				A450									
Dimensions of standard intermediate flange													
Standard intermediate flange		A250	A300	A300-1	A350	A400	A400-1	A450	A450-1	A550	A550-1	A660	A800
Diameter mm	a	250	300	300	350	400	400	450	450	550	550	660	800
	b	215	265	265	300	350	350	400	400	500	500	600	740
	c H7	180	230	230	250	300	300	350	350	450	450	550	680
Length mm	o	18	18	18	20	22	22	24	24	24	24	30	30
	q	5	5	5	6	6	6	6	6	6	6	7	7
	r	13		13			17.5		17.5		17.5		
Screws		k	4xM12	4xM12	4xM12	4xM16	4xM16	4xM16	8xM16	8xM16	8xM16	8xM16	8xM20

Spring Set Brake SFB-SH

Electromagnetic Two Disc, Spring Set Brake
Increased brake torque



Rev. 05-08

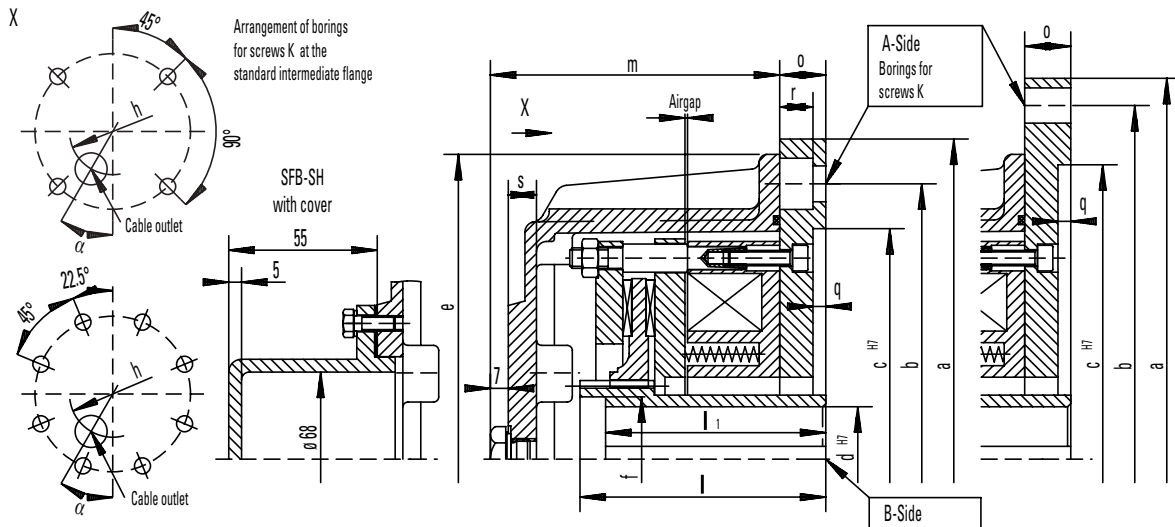

Brake size		SFB 400-SH	SFB 630-SH	SFB 1000-SH	
Brake torque M2 dynamic acc. to DIN VDE 0580	Nm	5200	8000	13000	
		4800	7500		
		4400	6900		
Mass moment of inertia	kgm ²	0.325	0.375	1.007	
Mass (weight)	kg	357	500	750	
max. speed	min ⁻¹	2500	2200	2000	
Coil b. 20° C	Nominal voltage	V DC	110	110	110
	Nominal power	W	553	671	980
	Nominal current	A	5.03	6.10	8.91
Air gap, brake OFF		min. mm	0.4	0.7	0.7
		max. mm	2.5	2.8	3.1
Diameter mm	B-Side	d Rough boring	46	58	68
		d ^{H7} Preferential boring	65	100	125
			70		
			75		
			80		
			90		
d ^{H7} maximal	110	125	140		
Length mm	e	660	700	795	
	f	128	140	155	
	h	520	570	620	
	l	191	237	282	
	l ¹	171	210	255	
	m	272	310	360	
	s	15	15	15	
A	α °	30	30	30	
Suitable standard intermediate flange		A660-1	A800	A800-1	
		A800			
Dimensions of standard intermediate flange					
Standard intermediate flange		A660-1	A800	A800-1	
Diameter mm	a	660	800	800	
	b	600	740	740	
	c ^{H7}	550	680	680	
Length mm	o	30	30	30	
	q	7	7	7	
	r	21.5		21.5	
Screws		k	8xM20	8xM20	

Keyways for keys acc. to DIN6885 Bl.1,
width accuracy P9. Protection IP67

Alterations reserved without notice

Spring Set Brake KFB



PINTSCH BUBENZER
is certified according to
DIN EN ISO 9001:2015



Reliable



High Performance



Robust



Easy Maintenance



Compact



Tried and Trusted

Description KFB



Main Features

Spring applied safety brake
Electromechanically released
Protection-class IP67 – seawater protected
High wear reserve by multiple air gap adjustment
Small construction at high work capacity
High availability caused by high durability
Functional without cover
Emergency release screws

Applications

Gantry, trolley and hoisting application
Dynamic and static use at general industrial applications
General engineering
Steel mills
Wind energy systems
Coal mining

Certificates

ABS, ATEX

Options

Special brake torque
Handlever
Micro or proximity switch: <ul style="list-style-type: none">• Monitoring the function on/off• Maximum air gap (wear-monitoring)
Lateral junction box
Tacho preparation with all mounting parts
Cover bore
Shaft sealing
Special voltage
Anti condensation heater
Radial cable outlet
Special flange

Electrical equipment

One-way, bridge and switching rectifier
Protective element
Brake control unit = BCU 2001
Brake control and monitoring system = BCMS-4



Please Note

We supply a detailed operating manual with every order. Nevertheless, we would point out that brakes are only as safe as the servicing and maintenance performed while they are in operation. The guarantee for the correct functioning of our brakes is only valid if the user adheres to the German DIN standard 15434 part 2 (drum and disc brakes, servicing and maintenance in operation), or to comparable standards in his own country.



PINTSCH BUBENZER Service

This includes the verification of the brake selection, if required. A detailed questionnaire is provided for this purpose. Installation and commissioning on-site by PINTSCH BUBENZER service engineers is possible. Drawings as DWG/DXF files for your engineering department are available upon request.

Spring Set Brake KFB

Electromagnetic Two Disc, Spring Set Brake



Rev. 10-09

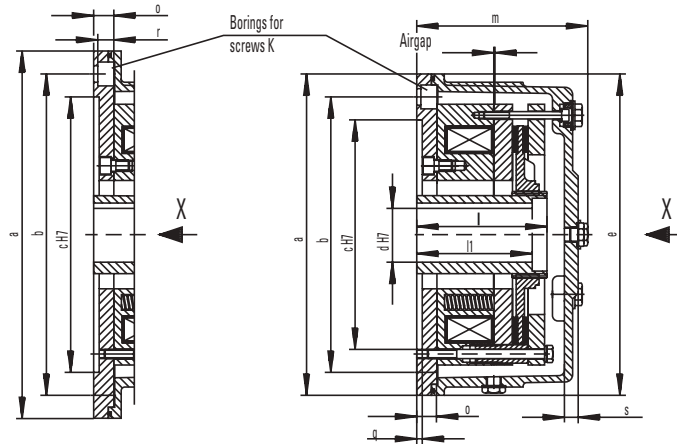
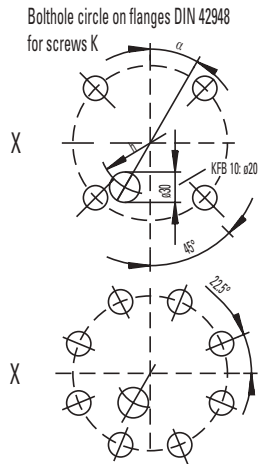

* The larger dimension belongs to the larger assigned brake.

Alterations reserved without notice.

Brake size		KFB 5	KFB 10	KFB 16	KFB 25	KFB 30	KFB 40	KFB 63	KFB 100	KFB 160	
Brake torque M2 dynamic acc. to DIN VDE 0580 Nm		50	100	160	250	300	400	630	1000	1600	
Mass moment of inertia kgm ²		0.0010	0.0017	0.0037	0.0048	0.0055	0.0068	0.0175	0.036	0.050	
Mass (weight) kg		13	19	28	42	50	55	74	106	168	
max. speed min ⁻¹		6000	6000	6000	6000	6000	5500	4700	4000	3600	
Coil b. 20° C	Nominal voltage V DC	110	110	110	110	110	110	110	110	110	
	Nominal power W	79	93	128	158	133	196	220	307	344	
	Nominal current A	0.72	0.84	1.16	1.44	1.2	1.78	2.0	2.79	3.13	
Air gap, OFF norm. mm		0.3	0.3	0.3	0.3	0.3	0.3	0.4	0.4	0.4	
max. mm		0.8	1.0	1.0	1.2	0.8	1.2	1.3	1.6	1.8	
Diameter mm	B-Side	d pilot bore	8	26	26	36	26	36	36	36	36
		d H7 preferential bore	15	28	28	38	32	38	48	60	60
			20	32	32	42	38	42	55	65	65
			25	38	38	48	42	48	60	75	75
					55	45	55				
Length mm	e	160/200	200/250	253/303	300/350	250/300	303/350	350/400	400/450	450/550	
	f										
	h	93	106	144	194	144	194	214	264	314	
	l	110	110	96	117	137	117	142	148	155	
	l ¹	110	110	96	117	137	117	142	142	142	
	m	145	154	141	165	175	175	187	196	218	
	s	13	15	15	15	15	15	15	15	17	
A	α °	22.5	30	30	30	67.5	30	30	30	30	
Suitable standards flanges		A160	A200	A250	A300	A250	A300	A350	A400	A450	
		A200	A250	A300	A350	A300	A350	A400	A450	A550	
		Dimensions of standards flanges									
Size of standards flanges		A160	A200	A250	A300	A350	A400	A450	A550		
Diameter mm	a	160	200	250	300	350	400	450	550		
	b	130	165	215	265	300	350	400	500		
	c H7	110	130	180	230	250	300	350	450		
Length mm	o	18	18	18/20*	20/22*	22	22/24*	24/29*	24/29*		
	q	5	5	5	5	6	6	6	6		
	r	11	11	13	13	17.5	17.5	17.5	17.5		
	k	4xM8	4xM10	4xM12	4xM12	4xM16	4xM16	8xM16	8xM16		

Notes



Horizontal lines for writing notes.

Accessories

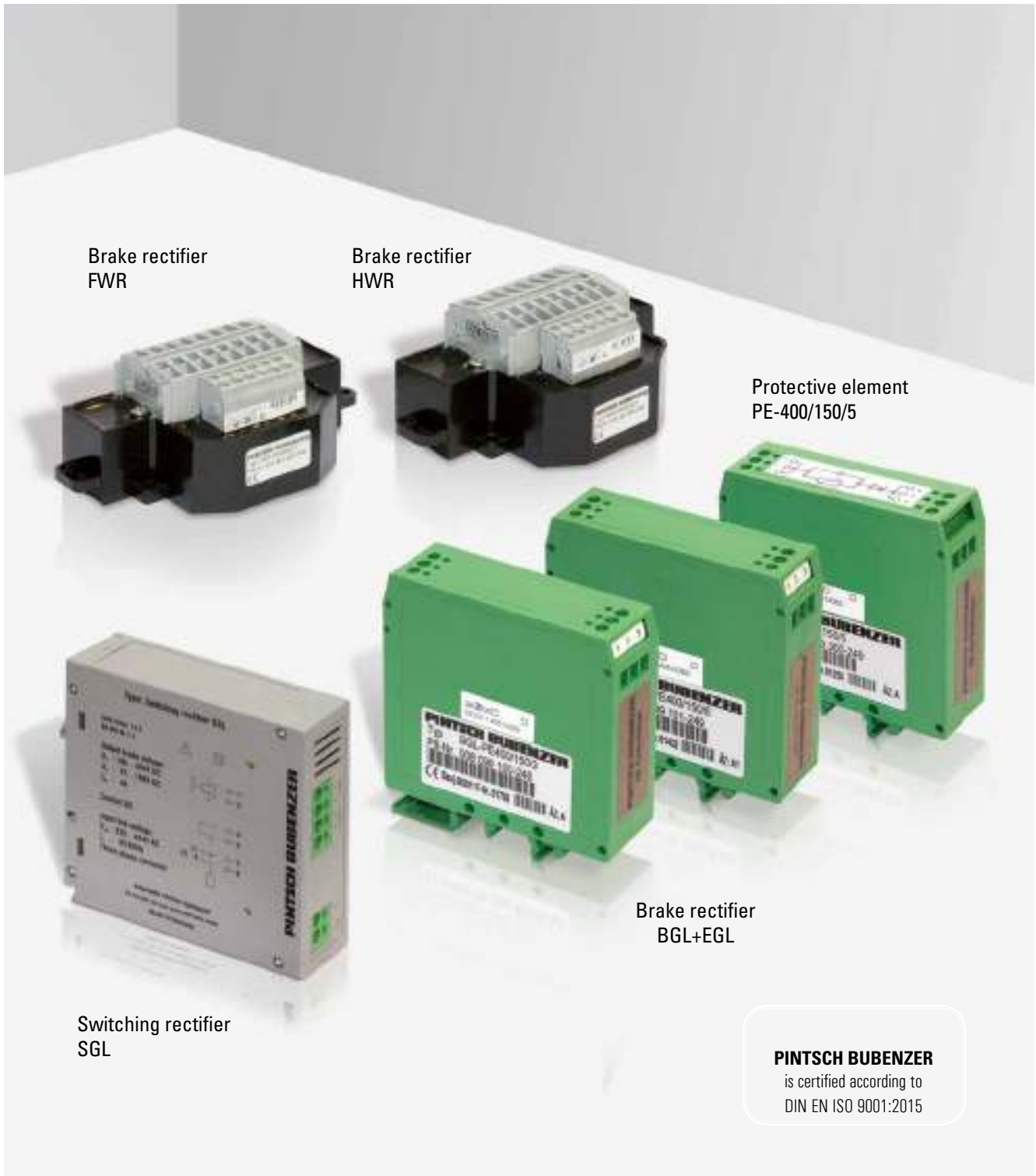

Brake rectifier
FWR

Brake rectifier
HWR

Protective element
PE-400/150/5

Brake rectifier
BGL+EGL

Switching rectifier
SGL

PINTSCH BUBENZER
is certified according to
DIN EN ISO 9001:2015



Reliable



High Performance



Robust



Easy Maintenance



Compact



Tried and Trusted

Description Accessories



Main Features

EMC compatibility
Top-hat rail mounted
Combinable with Brake Control Unit BCU2001
Integrated protective element
Integrated spark quench element

Specific Features for the rectifiers BGL and EGL

Prepared for switching AC and DC circuits simultaneously
Installation in cabinet

Specific Features for the protective element PE 400/150/5

To be connected parallel to the output of the rectifiers BGL, EGL and SGL to increase the interruption capacity

Specific Features for the rectifiers FWR and HWR

Prepared for switching AC and DC circuits simultaneously
Installation in junction box

Specific Features of the switching rectifier SGL

Prepared for switching AC and DC circuits simultaneously
Switches from bridge rectification to half-wave rectification
Four time settings 0,5 s, 1 s, 1,5 s, 2 s adjustable
Applying brakes at elevated temperatures
Accelerated brake release (Overexcitation with AC power supply voltage = 2 x DC coil voltage)
Accelerated brake effect (Standard excitation with AC power supply voltage = DC coil voltage)



Please Note

We supply a detailed operating manual with every order. Nevertheless, we would point out that brakes are only as safe as the servicing and maintenance performed while they are in operation. The guarantee for the correct functioning of our brakes is only valid if the user adheres to the German DIN standard 15434 part 2 (drum and disc brakes, servicing and maintenance in operation), or to comparable standards in his own country.



PINTSCH BUBENZER Service

This includes the verification of the brake selection, if required. A detailed questionnaire is provided for this purpose. Installation and commissioning on-site by PINTSCH BUBENZER service engineers is possible. Drawings as DWG/DXF files for your engineering department are available upon request.

BGL-PE400/150/3 - EGL-PE400/150/5

Principal circuit diagram



Rev. 03-09

Bridge rectification with module BGL

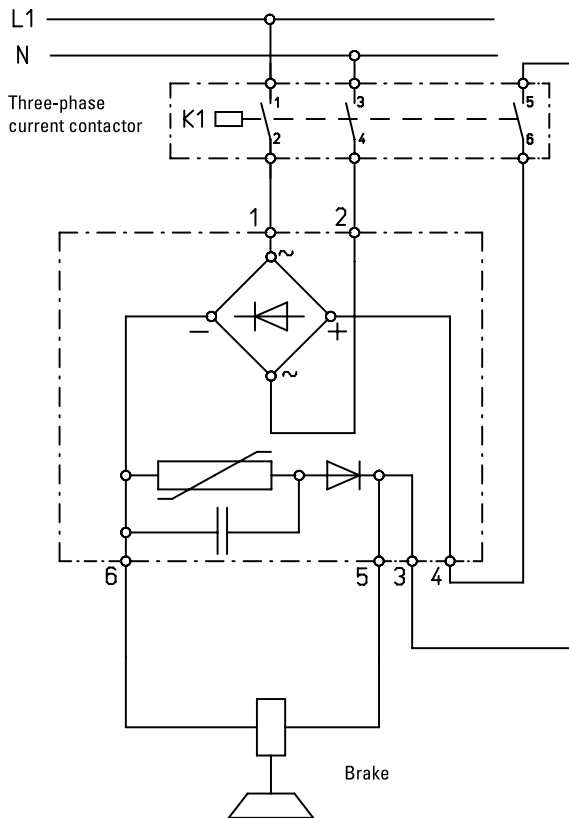

Half-wave rectification with module EGL

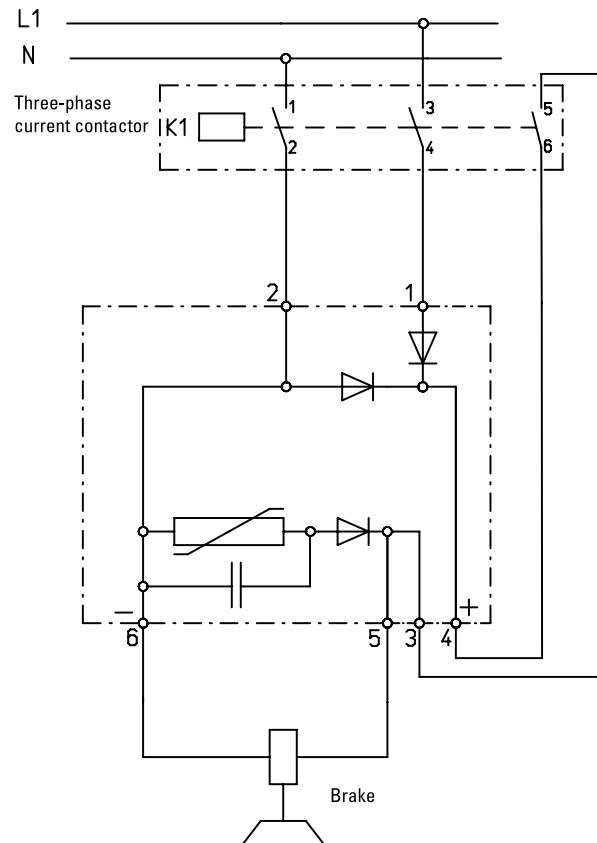

Technical data

Brake rectifier BGL-PE400/150/3

AC line voltage:	AC 460V; 50/60 Hz
Permissible rated coil voltages:	DC 24V...390V
Maximum brake current:	2,5A
Maximum continuous output of the internal protective circuit:	3W
Disconnection peak at maximum coil current:	≤450V
Ambient temperature:	-40° C ... +50° C
Protection class:	IP 20

Brake rectifier EGL-PE400/150/5

AC line voltage:	AC 460V; 50/60 Hz
Permissible rated coil voltages:	DC 24V...220V
Maximum brake current:	5A
Maximum continuous output of the internal protective circuit:	5W
Disconnection peak at maximum coil current:	≤450V
Ambient temperature:	-40° C ... +50° C
Protection class:	IP 20

Full wave rectifier FWR-PE400/150/3

Principal circuit diagram



Rev. 10-10

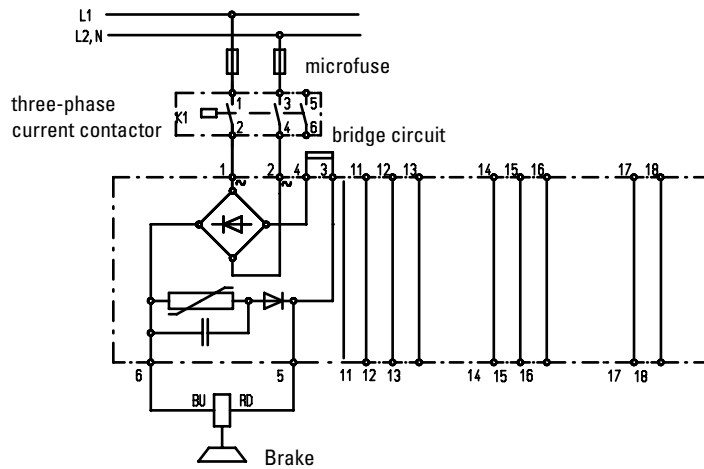

load diagram

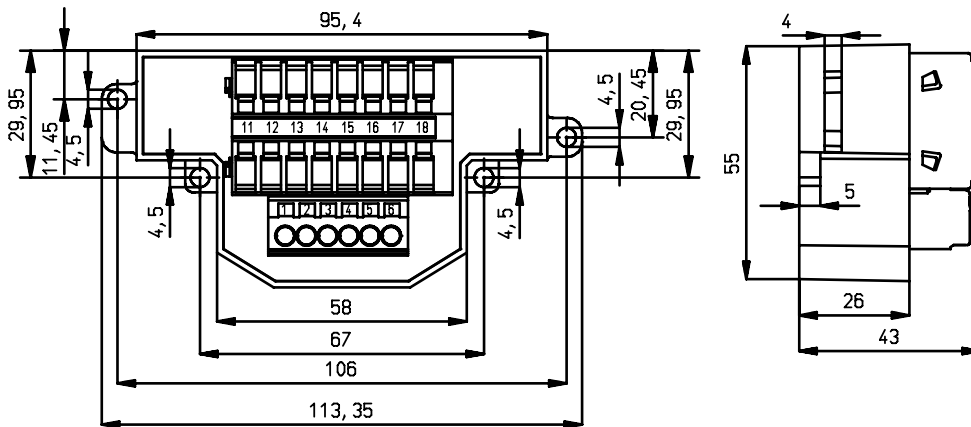
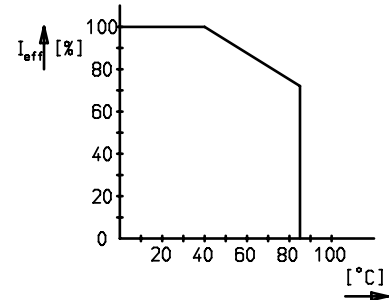

Technical data

Coil voltage of the connected brake	DC 24V ... 390V
Max. voltage of supplying alternating current network	AC 460V - 50/60 Hz
Max. Output current I_{eff} at $T_A = < 50^\circ\text{C}$	2,5 A
Max. Output current I_{eff} at max. T_A 85°C	1,8 A
Protection fuse in the AC input voltage line to the rectifier (In the selection of fuse is permissible on the $I^2 t$ limit load integral to eight)	FF 4A microfuse switching capacity H
Permitted limit integral $I^2 t$	700A ² s (t < 10ms)
Max. energy absorption of a shut-off	150 J
Max. continuous power of the internal protective circuit (average value)	3W
Shut-off peak at max. coil current	< 450V
Ambiente temperature T_A	-40° C ... +85° C
Permissible cross section of connection wire	0,2 ... 2,5 mm AWG 24 ... 14
Weight	0,3 kg
Protection class	IP 65 components seal / IP20 terminals
Mark of conformity	CE / RoHS conform

Half wave rectifier HWR-PE400/150/5

Principal circuit diagram



Rev. 10-10

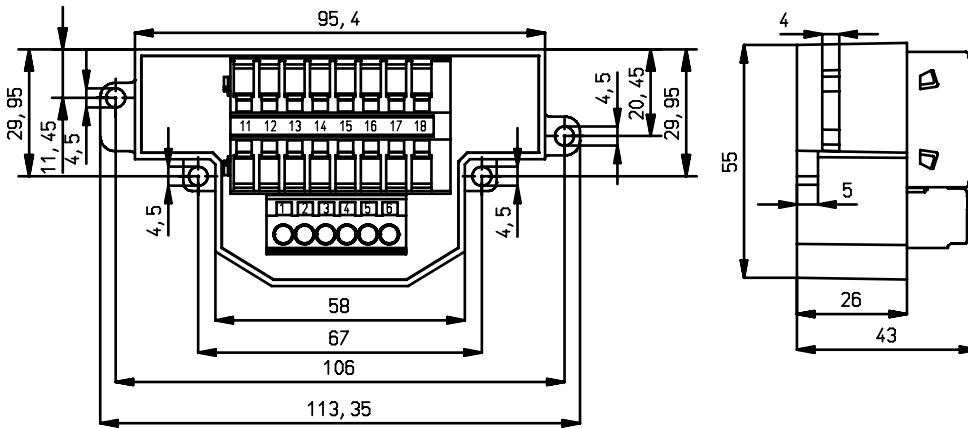
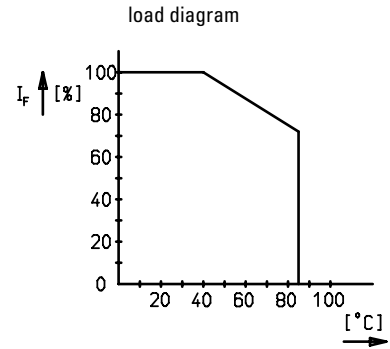
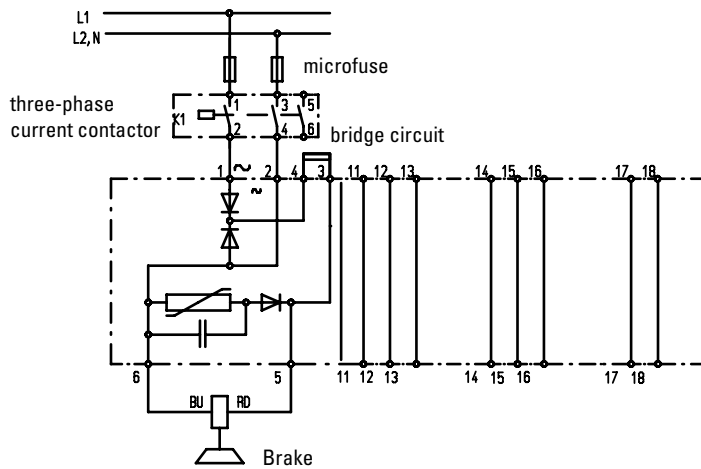

Technical data

Coil voltage of the connected brake	DC 24V ... 240V
Max. voltage of supplying alternating current network	AC 550V - 50/60 Hz
Max. Output current I_{eff} at $T_A = < 50^\circ\text{C}$	5 A
Max. Output current I_{eff} at max. T_A 85°C	3,6 A
Protection fuse in the AC input voltage line to the rectifier (In the selection of fuse is permissible on the $I^2 t$ limit load integral to eight)	FF 4A microfuse switching capacity H
Permitted limit integral $I^2 t$	700A ² s (t <10ms)
Max. energy absorption of a shut-off	150 J
Max. continuous power of the internal protective circuit (average value)	5W
Shut-off peak at max. coil current	< 450V
Ambiente temperature T_A	-40° C ... +85° C
Permissible cross section of connection wire	0,2 ... 2,5 mm AWG 24 ... 14
Weight	0,3 kg
Protection class	IP 65 components seal / IP20 terminals
Mark of conformity	CE / RoHS conform

Switching rectifier SGL

Principal circuit diagram



Rev. 03-09

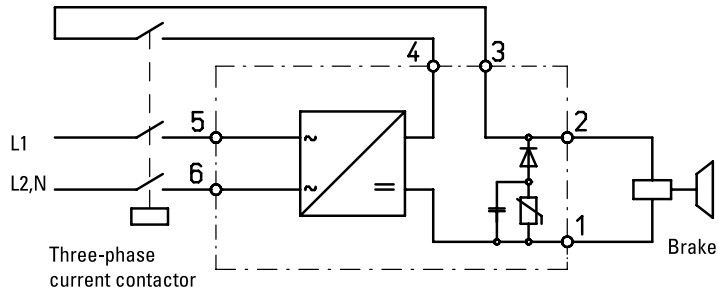

Switching rectification with module SGL

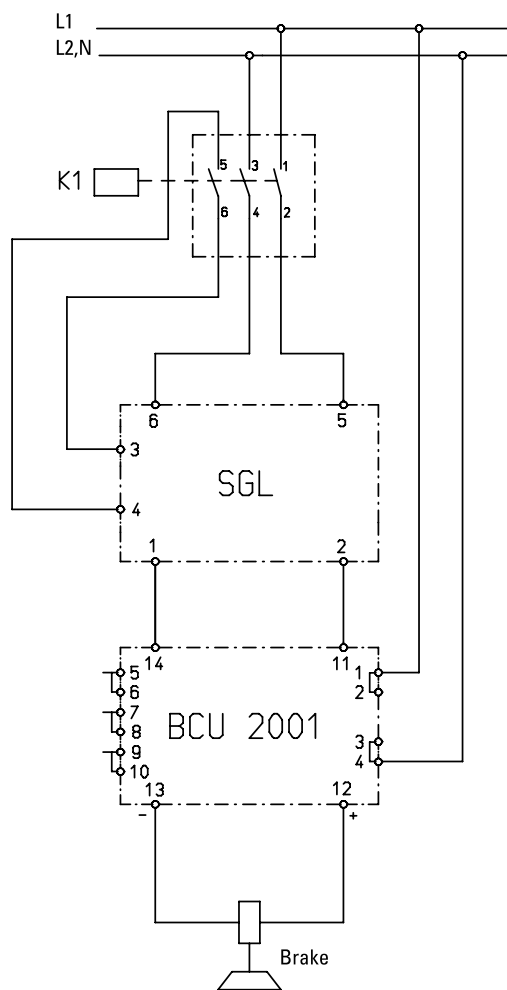

Switching rectification with module SGL combined with the Brake Control Unit BCU2001

Technical data

AC line voltage:	AC 220V...484V; 50/60 Hz
Maximum brake current for 2 s:	8A
Maximum continuous output of the internal protective circuit:	5 W
Permanent brake current:	4A
Time settings by DIP switch:	0,5 s, 1 s, 1,5 s, 2,0 s
Ambient temperature:	-40° C ... +50° C
Protection class:	IP 20

Protective element PE-400/150/5

Principal circuit diagram



Rev. 03-09

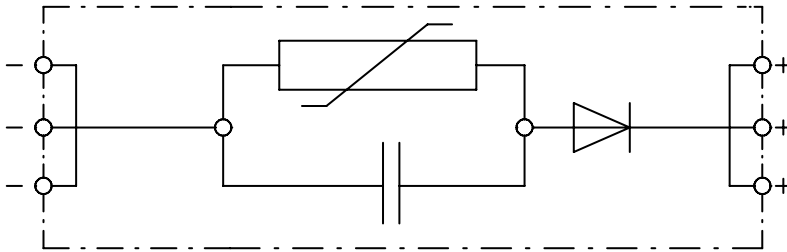

Protective element
PE-400/150/5

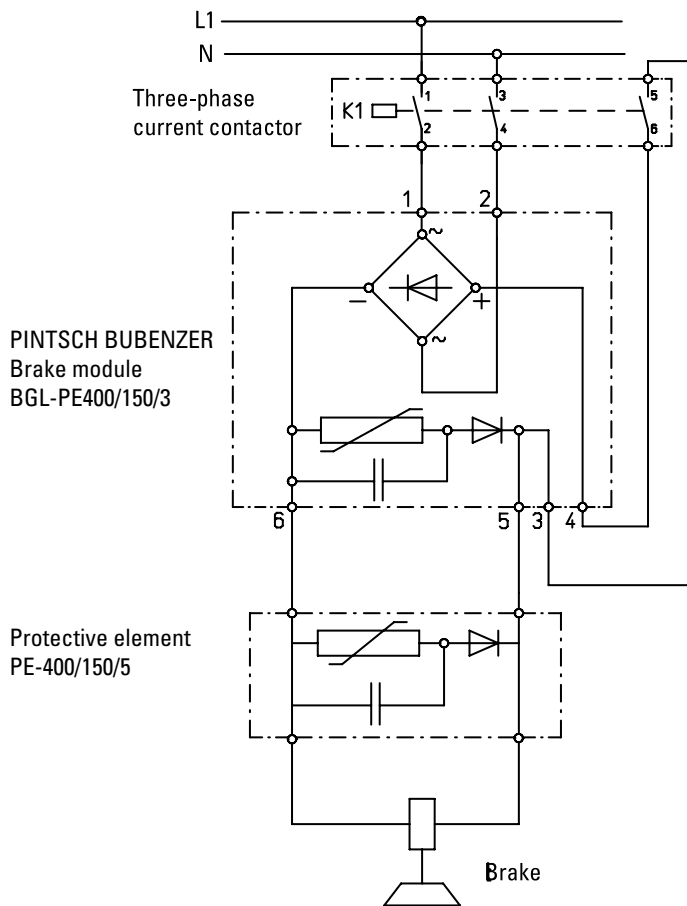

Bridge rectification with
module BGL combined
with the protective element
PE-400/150/5

Technical data

Maximum brake voltage:	DC 400V
Maximum brake current:	5A
Maximum continuous output of the internal protective circuit:	5W
Disconnection peak at maximum coil current:	≤ 450V
Ambient temperature:	-40° C ... +50° C
Protection class:	IP 20

Notes



A series of horizontal lines providing space for handwritten notes.

Brake Control Unit BCU2001



PINTSCH BUBENZER
is certified according to
DIN EN ISO 9001:2015



Reliable



High Performance



Robust



Easy Maintenance



Compact



Tried and Trusted

Description Brake Control Unit BCU2001



Main Features

EMC compatibility
Maximum air gap (wear) indication by LED
Maximum air gap indication by relay contact
Function on/off indication by LED
Function on/off indication by relay contact
No sensors on the brake
No sensor wiring to the brake
Perfect retrofit equipment
Directly connectable with PLC systems
AC and DC auxiliary power supplies applicable
Top-hat rail mounted

Applications

Container cranes
Ship winches
Automatic racking systems
Conveyor belts
General electrical drives

Options

Combinable with the switching rectifier SGL in overexcitation mode
Combinable with bridge rectifier BGL-PE400/150/3
Combinable with half-wave rectifier EGL-PE400/150/3

Method

The Brake Control Unit BCU 2001 records characteristic current and voltage variations, which are induced by movements of the armature disk in the magnetic field of the brake coil. In an interference free and reliable manner it evaluates the signal levels in terms of the control state (applied or released) and the maximum air gap (maximum wear)

Important requirements

AC and DC circuit to be switched simultaneously
AC circuit may not be switched alone



Please Note

We supply a detailed operating manual with every order. Nevertheless, we would point out that brakes are only as safe as the servicing and maintenance performed while they are in operation. The guarantee for the correct functioning of our brakes is only valid if the user adheres to the German DIN standard 15434 part 2 (drum and disc brakes, servicing and maintenance in operation), or to comparable standards in his own country.



PINTSCH BUBENZER Service

This includes the verification of the brake selection, if required. A detailed questionnaire is provided for this purpose. Installation and commissioning on-site by PINTSCH BUBENZER service engineers is possible. Drawings as DWG/DXF files for your engineering department are available upon request.

Brake Control Unit BCU2001

Principal circuit diagram



Rev. 03-09

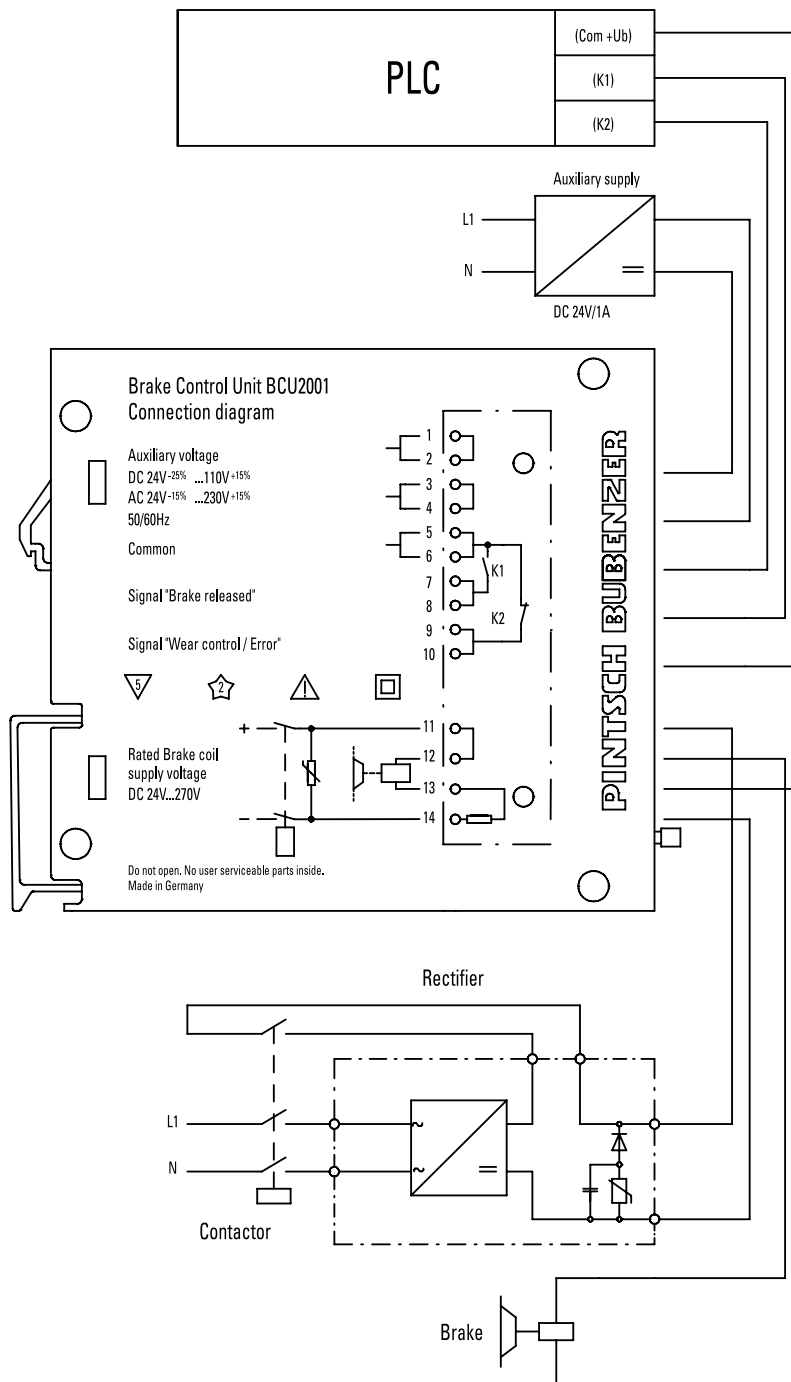

Technical data

Permissible coil voltages:	DC 24V ... 396V
Ambient temperature:	-40° C ... +50° C
Protection class:	IP 20
Permissible auxiliary power supplies:	AC 24 V -15% ... AC 230 V +15% DC 24 V -25% ... DC 110 V +15%

Brake Control Unit BCMS-4



PINTSCH BUBENZER
is certified according to
DIN EN ISO 9001:2015



Reliable



High Performance



Robust



Easy Maintenance



Compact



Tried and Trusted

Description Brake Control Unit BCMS-4



Main Features

■	Plug and play – minimal configuration and implementation effort
■	No micro- or proximity switches required for the brake (much lower amount of wiring)
■	Components such as contactors, power rectifier, suppressor to be omitted (space and cost savings)
■	Through the use of plug-in terminals a prior installation of the connecting cables is possible (saves time)
■	Normal maintenance intervals are not required on our brakes (extreme reduction of maintenance costs)
■	Due to the 4-channel version up to four spring-loaded brakes can be operated simultaneously
■	Certified safety through professional association
■	In conjunction with a superior safety PLC operation by security classification DIN EN ISO 13849-1 PL d, Cat 3 is possible
■	Internal 2-channel safety logic in redundant design
■	Providing I / O diagnostic outputs for integration into PLC
■	Quick releasing and closing of the brakes
■	Overcurrent trip to protect the brakes
■	Wire break recognition
■	Minimize the power dissipation of the brakes by regulation the holding current
■	Internal menu structure

■	Representation of the status wear
■	User interface RS 232 for connection and intervention in the menu structure
■	Manual operation of the menu structure
■	The operating status and diagnostic messages are be visualized and displayed at the unit itself
■	Optimization of the wear allowance
■	„One solution, one source“

Applications

■	Container cranes
■	Ship winches
■	Automatic racking systems
■	Conveyor belts
■	General electrical drives

Method

The BCMS-4 is a micro-controller-based monitoring and switching device for spring applied brakes of the SFB and KFB series. Through measurement and analysis of current and voltage of the outgoing two-wire lines of the individual brakes wear and switching state of each electromagnetic spring-applied brake can be detected in some distant mounting position. There can be up to four brakes operated and evaluated simultaneously. The operation of the brakes is fundamentally with rapid releasing and closing of the brakes.



Please Note

We supply a detailed operating manual with every order. Nevertheless, we would point out that brakes are only as safe as the servicing and maintenance performed while they are in operation. The guarantee for the correct functioning of our brakes is only valid if the user adheres to the German DIN standard 15434 part 2 (drum and disc brakes, servicing and maintenance in operation), or to comparable standards in his own country.



PINTSCH BUBENZER Service

This includes the verification of the brake selection, if required. A detailed questionnaire is provided for this purpose. Installation and commissioning on-site by PINTSCH BUBENZER service engineers is possible. Drawings as DWG/DXF files for your engineering department are available upon request.

Brake Control Unit BCMS-4

Principal circuit diagram



Rev. 11-11

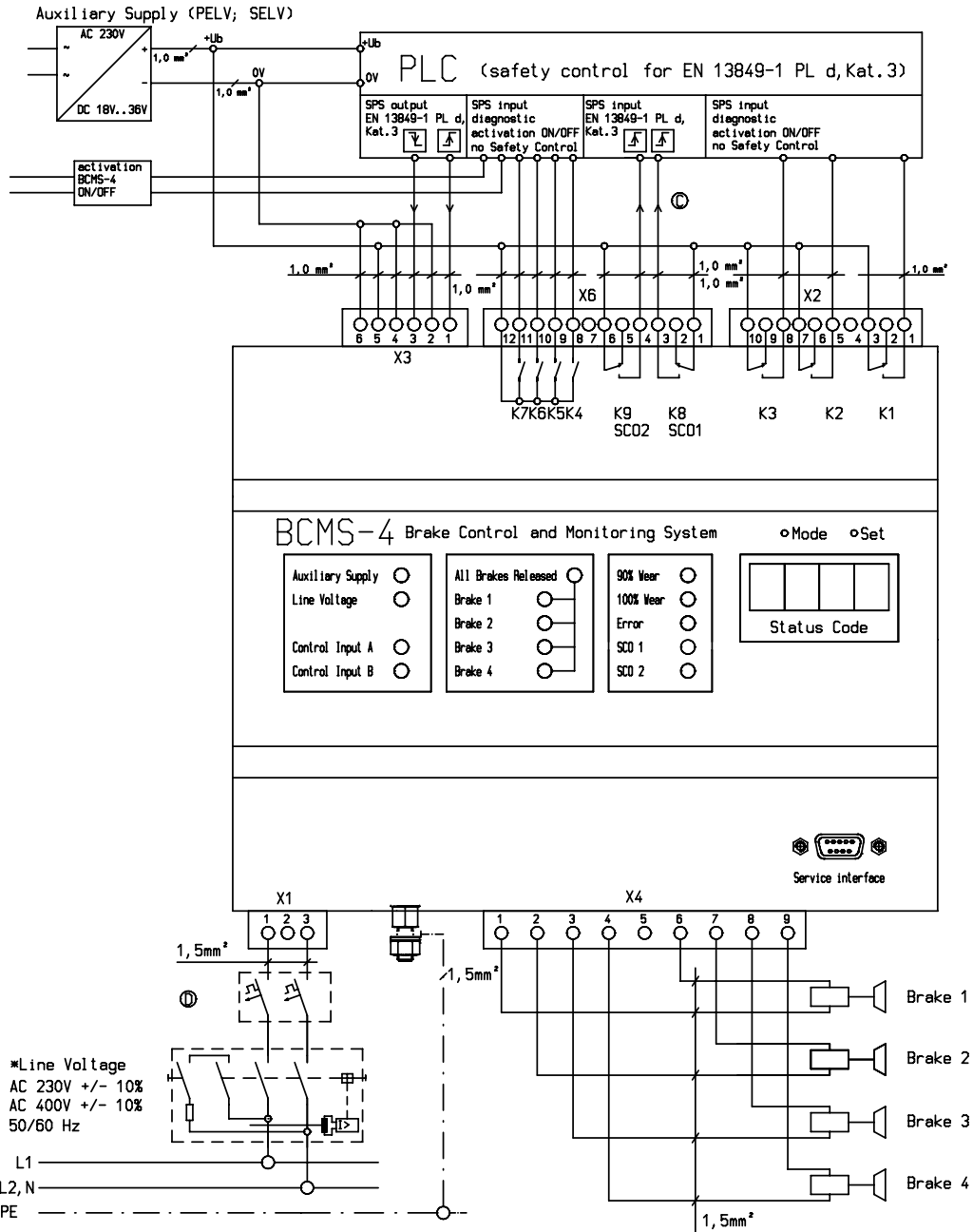

Technical data

Permissible auxiliary power supplies:	AC 230V +/- 10%; 50/60 Hz AC 400V +/- 10%; 50/60 Hz
Ambient temperature:	-30°C +50°C
Protection class:	IP 20
Permissible coil voltages:	110 V DC and 207 V DC
security rating:	DIN EN ISO 13849-1 PL d, Cat 3
PFHD:	1.16 ⁻⁷

Disc Brake SB 17 MX Series

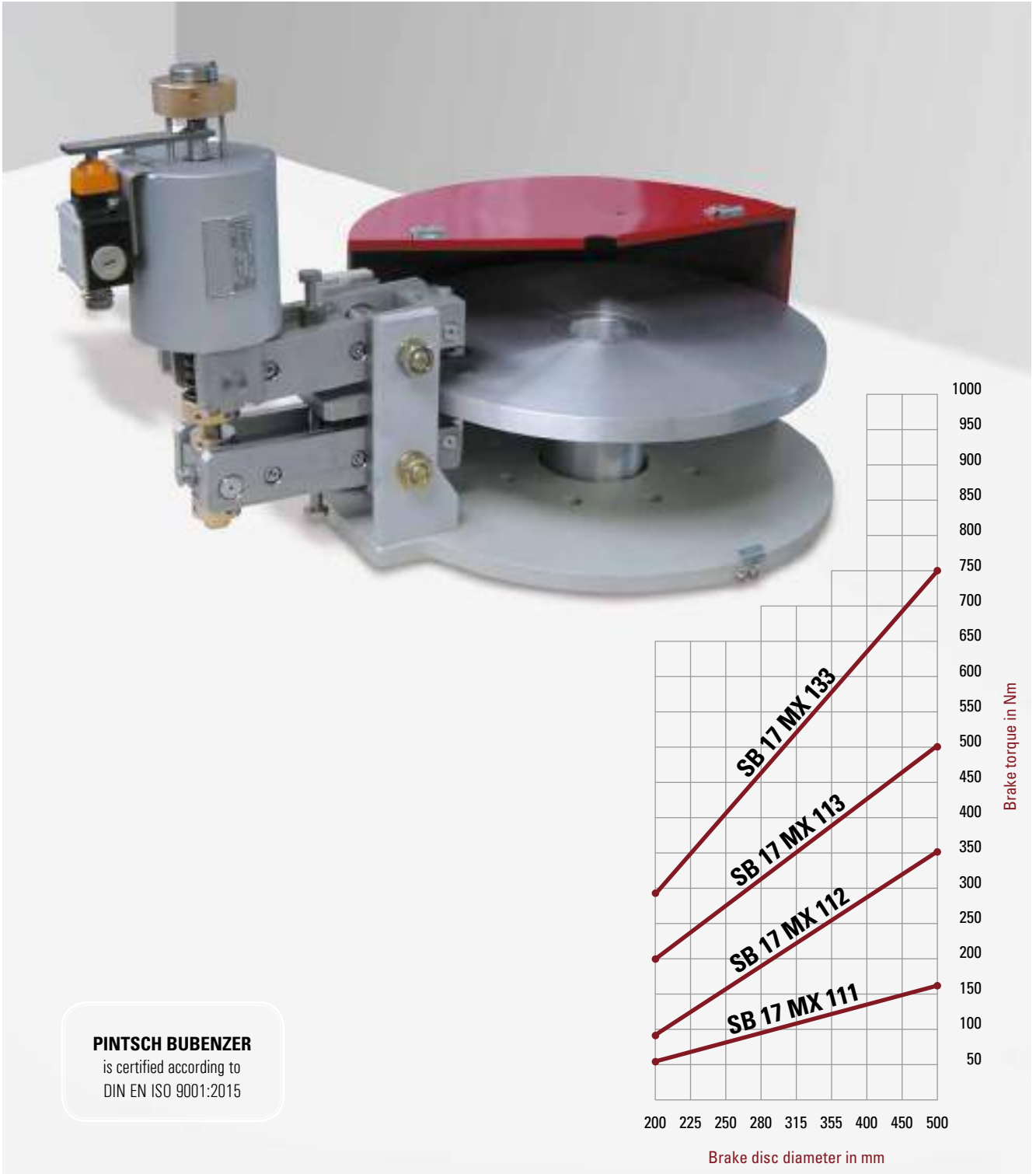

PINTSCH BUBENZER
is certified according to
DIN EN ISO 9001:2015



Reliable



High Performance



Low Maintenance



Compact

Description SB 17 MX



Main Features

Electromagnetic release
High performance by overforcing of electromagnet (magnet IP54)
Internal rectifier / economizer unit, direct connection to 380-480 V AC, 3 Ph., 50-60 Hz
Adjustable brake torque
Simple, manual wear compensation
Organic, non-asbestos linings
Manual release and limit switch release control as a standard
Stainless steel brake body

Ordering Example

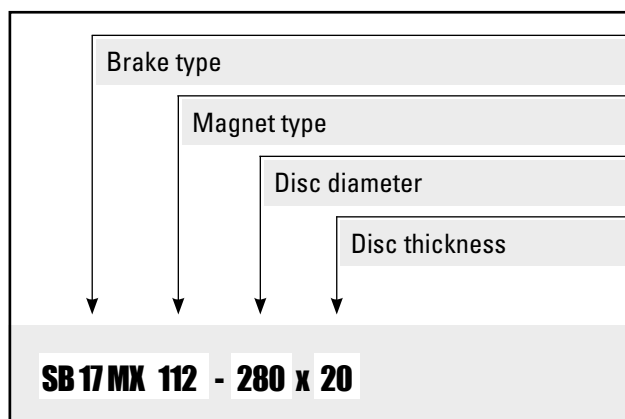

Options

Limit switch wear control
Sintered linings
Hydraulic damping unit for continuously adjustable apply time of 1-8 seconds
Motor connection flange incl. protective cover
Brake discs with hubs or couplings

Applications

The capacity of these brakes makes them particularly suitable as service brakes e.g. on crane gantries, slewing drives or smaller hoists.
In combination with the hydraulic damping unit, a soft and smooth braking is possible.
Very compact and easy to install as a motor mounted version

Magnets, Technical Data

Magnet Type	Inrush (W)	Holding (W)
111	100	100
112	360	100
113	360	100
133	360	100



Please Note

We supply a detailed operating manual with every order. Nevertheless, we would point out that brakes are only as safe as the servicing and maintenance performed while they are in operation. The guarantee for the correct functioning of our brakes is only valid if the user adheres to the German DIN standard 15434 part 2 (drum and disc brakes, servicing and maintenance in operation), or to comparable standards in his own country.



PINTSCH BUBENZER Service

This includes the verification of the brake selection, if required. A detailed questionnaire is provided for this purpose. Installation and commissioning on-site by PINTSCH BUBENZER service engineers is possible. Drawings as DWG/DXF files for your engineering department are available upon request.

Disc Brake SB 17 MX

Dimensions and technical data



Rev. 03-18
MB-001674 a

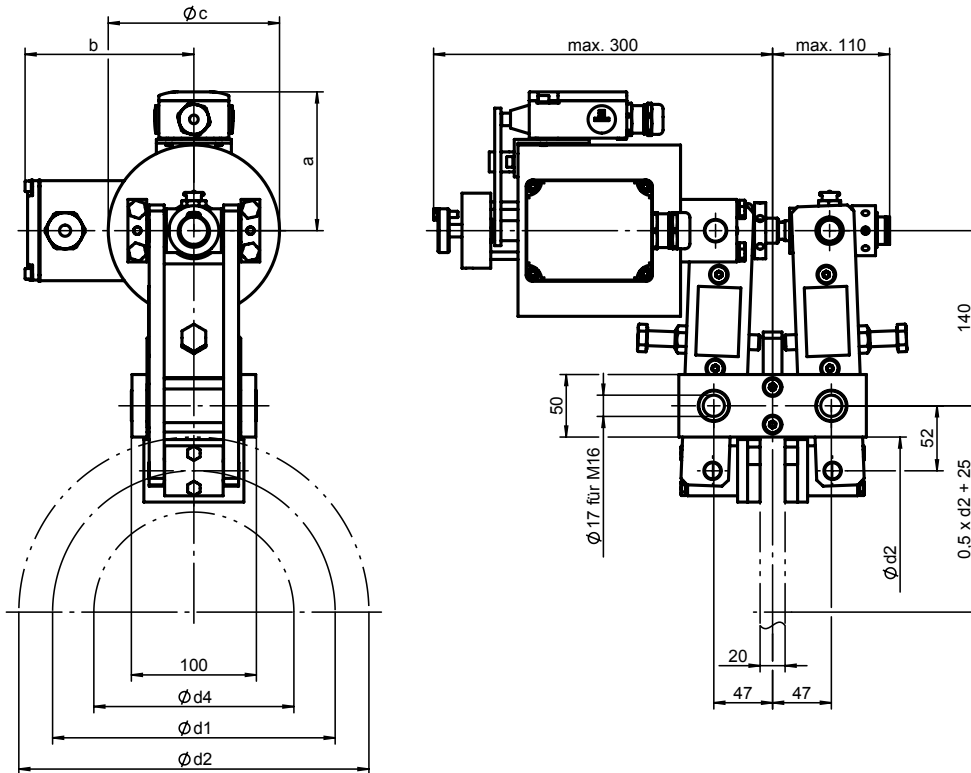

Magnet dimensions			Lining	
Type	a ca.	b ca.	Øc	b ₂
111	102	121	114	40
112	102	121	114	40
113	102	121	114	50
133	112	135	137	50

*) Average static coefficient of friction for standard material combination

The coefficient of friction is subject to fluctuations depending on operational-, material- and ambient-conditions! This must be considered during the selection!

For crane brake layout use safety factors documented in the FEM 1.001, Section 1

All dimensions in mm
Alterations reserved without notice

Weight with magnet: max. 24 kg		Magnet type	111	112	113	133
		Contact force in N	1100	2150	3150	4200
Disc-Ø d ₂	Friction-Ø d ₁	Max. hub-Ø d ₄	Brake torque M _{Br} in NM Friction factor μ = 0,4*			
200	146	80	60	130		
225	171	105	70	150		
250	196	130	85	170	250	
280	226	160	100	195	285	375
315	261	195	115	225	330	440
355	301	235			375	500
400	346	280			435	580
450	396	330				665
500	446	380				750

Disc Brake SB 17 MXs

with hydraulic damping unit – Dimensions and technical data



Rev. 03-18
MB-001676a

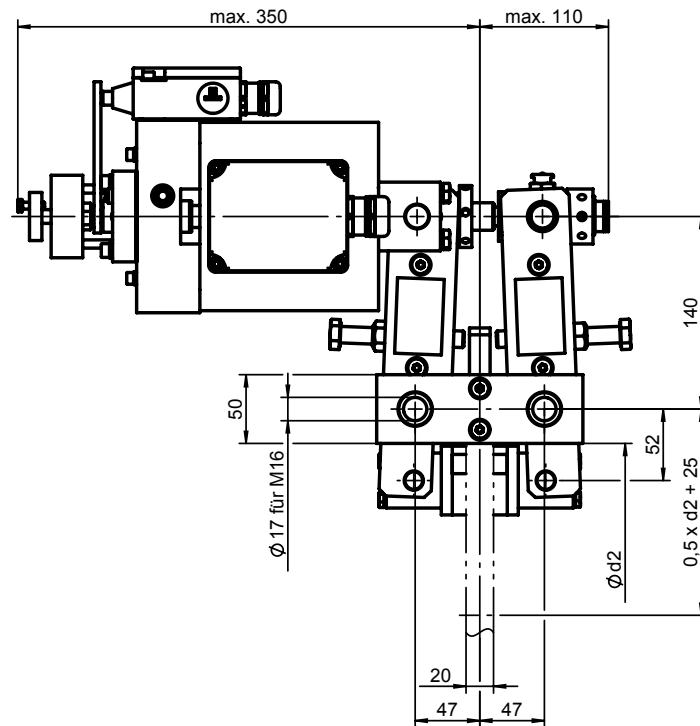
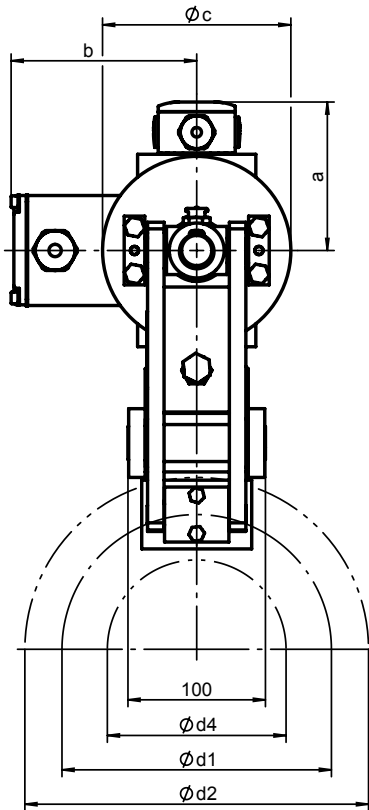

Magnet dimensions			Lining	
Type	a ca.	b ca.	Øc	b ₂
112	108	121	114	40
113	108	121	114	50
133	108	135	137	50

Apply time adjustable 1...8 seconds

*) Average static coefficient of friction for standard material combination

The coefficient of friction is subject to fluctuations depending on operational-, material- and ambient-conditions! This must be considered during the selection!

For crane brake layout use safety factors documented in the FEM 1.001, Section 1

All dimensions in mm
Alterations reserved without notice

Weight with magnet: max. 26 kg		Magnet type	112	113	133
		Contact force in N	1100	2150	3150
Disc-Ø d ₂	Friction-Ø d ₁	Max. hub-Ø d ₄	Brake torque M _{Br} in NM Friction factor μ = 0,4*		
200	146	80	58		
225	171	105	68	102	
250	196	130	78	117	235
280	226	160	90	135	270
315	261	195	104	155	310
355	301	235		180	360
400	346	280		207	415
450	396	330			475
500	446	380			535

Disc Brake SB 17 MX

Connecting diagram internal rectifier/economizer



Rev. 07-14

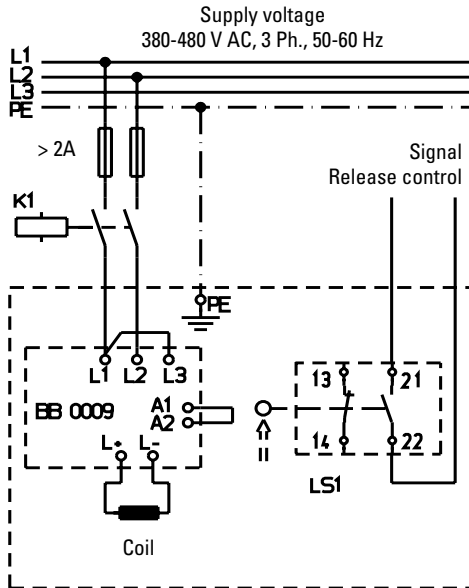

SB 17 MX 111

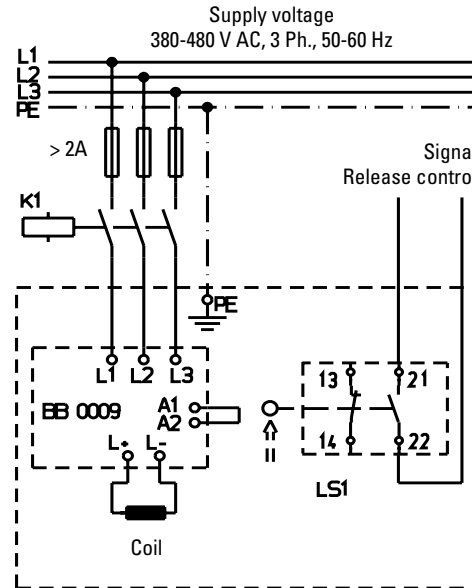

SB 17 MX 112/113/133

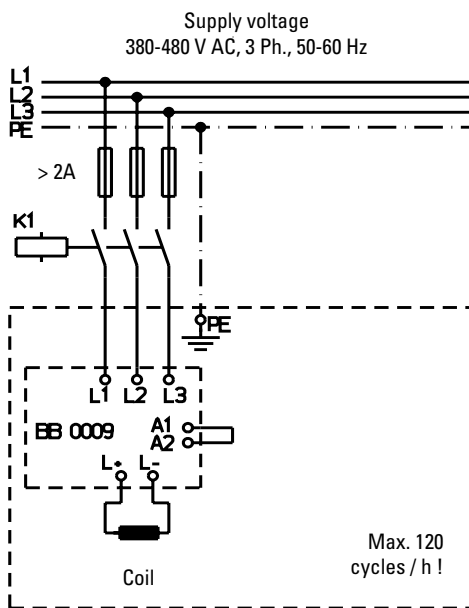

SB 17 MX without limit switch release control

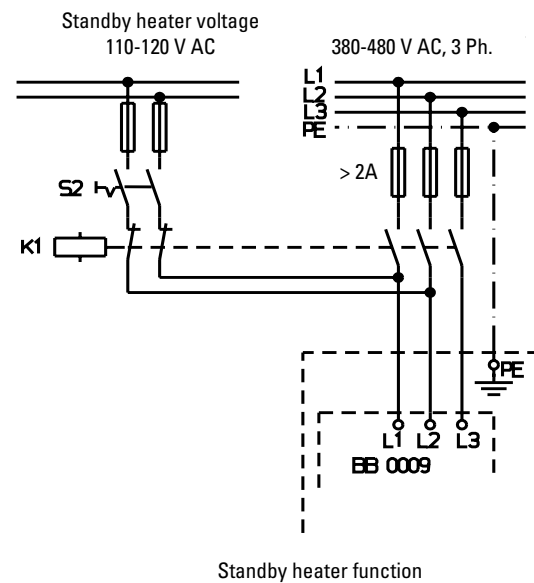

Standby heater function

Alterations reserved without notice

Supply voltage	Coil voltage
380-415 V AC	180 V DC
440-480 V AC	205 V DC

PINTSCH BUBENZER scope of supply:
SB 17 MX, coil
Rectifier / economizer BB0009 (built-in)
Limit switch LS1

Disc Brake SB 17 MX

Installation example, motor mounted version



Rev. 12-06

Brake mountable in each 45° steps

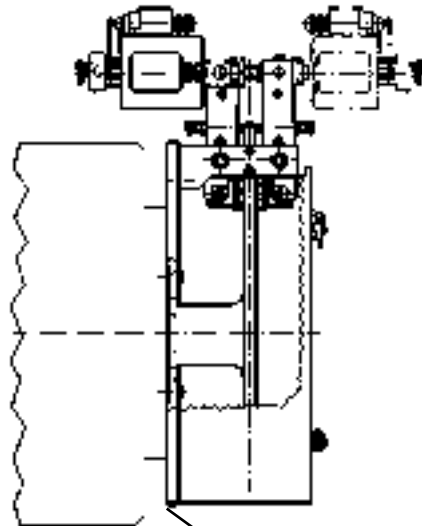
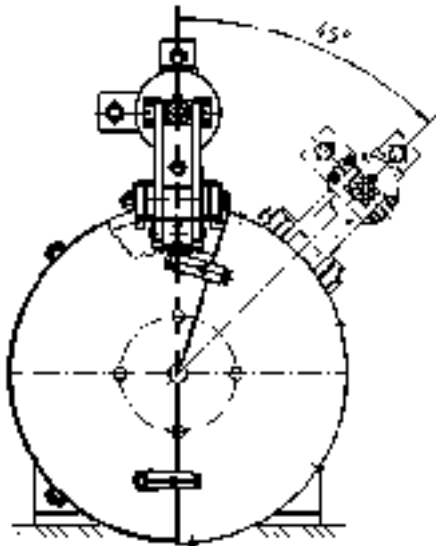

With cover IP00

Connection flange
Motor - Brake

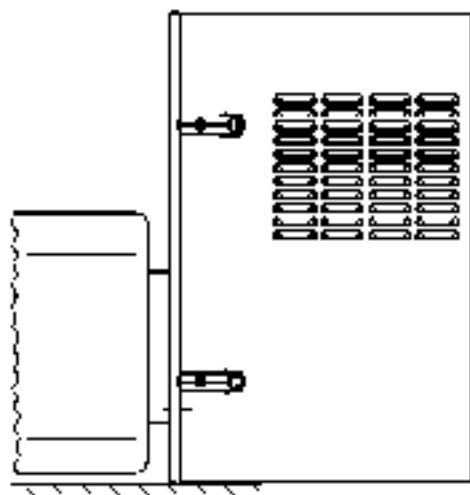
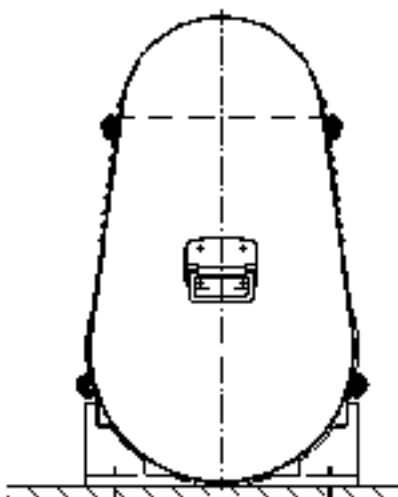

With cover IP22



When placing order, please indicate motor type.

Drum Brakes



PINTSCH BUBENZER
is certified according to
DIN EN ISO 9001:2015



Acc. to DIN 15435



Reliable



High Performance



Robust Design



Tried and Trusted

Description Drum Brakes



Main Features - Steel Mill Execution

Adherence to DIN 15435 standard
Stepless adjustable brake spring enclosed in a square tube with directly readable torque scale
Self-lubricating bushings mean brakes are easy to service, no greasing necessary
Even brake shoe release by adjustable lever stops
Up to size 400: Levers and base plate of nodular cast iron
From size 500: Levers and base plate welded steel
Thrusters for high ambient temperatures in steel mills
Spring split pins in the shoe pins for an easy and quick change of brake linings/shoes
Special shoe clamping

Options

Heavy-duty designed automatic wear compensator (dust-proof)
Heat resistant wiring of limit switches
Limit switch release control (special execution)
Limit switch wear control (special execution)
Limit switch manual release (special execution)
Manual release lever with or without stop
Monitoring systems (e.g. VSR)
Brake discs with hubs or couplings

Thrusters, Technical Data

Thruster Type	Power (W)	Curr. (A) at 400 V	Weight (kg)
Ed 23/5	165	0,5	10
Ed 30/5	200	0,5	14
Ed 50/6	210	0,5	23
Ed 80/6	330	1,2	24
Ed 121/6	330	1,2	39
Ed 201/6	450	1,3	39
Ed 301/6	550	1,4	40

Data supplied by thruster manufacturer, please take higher start current into consideration, fuses to be minimum 2A



Please Note

We supply a detailed operating manual with every order. Nevertheless, we would point out that brakes are only as safe as the servicing and maintenance performed while they are in operation. The guarantee for the correct functioning of our brakes is therefore only valid if the user adheres to the German DIN standard 15434 part 2 (drum and disc brakes, servicing and maintenance in operation), or to comparable standards in his own country.



PINTSCH BUBENZER Service

This includes the verification of the brake selection, if required. A detailed questionnaire is provided for this purpose. Installation and commissioning on site is possible by PINTSCH BUBENZER service engineers. Drawings as DWG/DXF files for your engineering department are available upon request.

Drum Brake Type EBN

Dimensions (DIN 15435) and technical data



Rev. 03-18
MB-001517 c

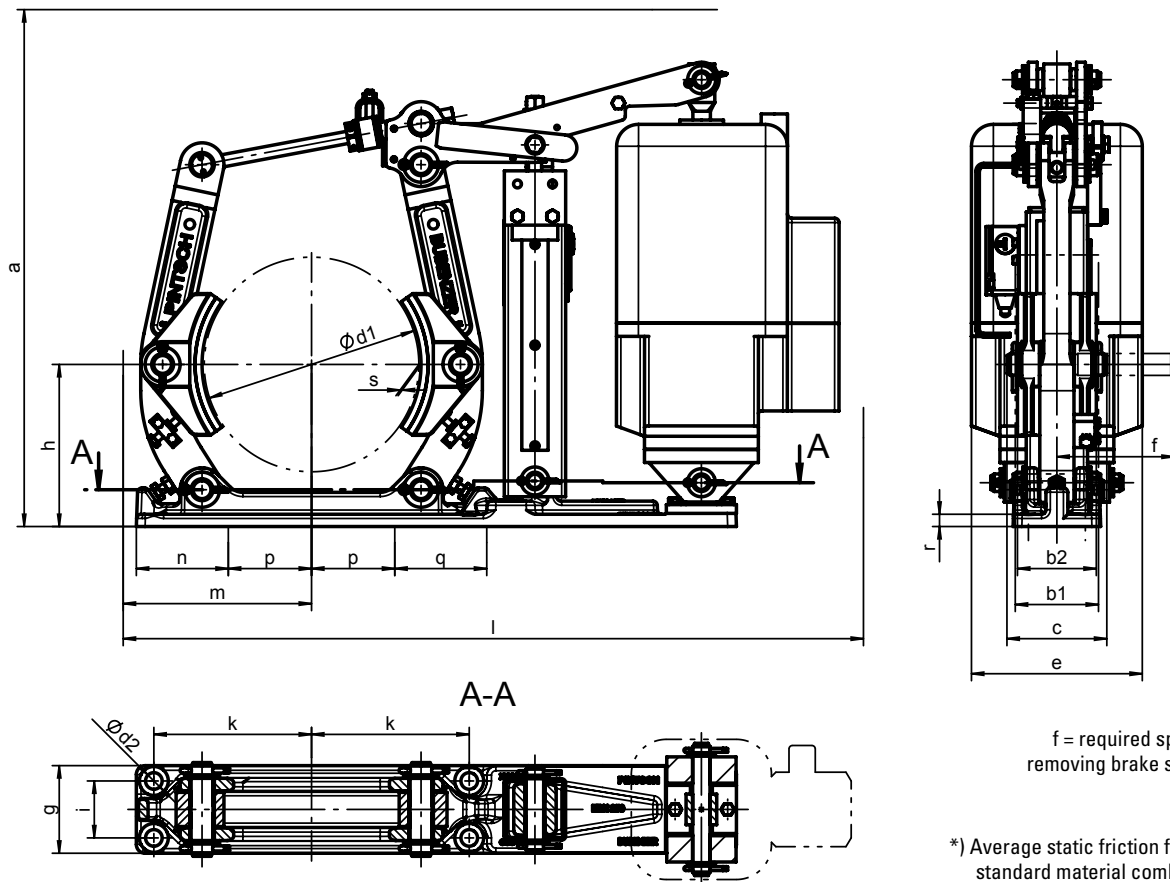

f = required space for removing brake shoe pin

*) Average static friction factor of standard material combination

All dimensions in mm
Alterations reserved without notice

The friction coefficient is subject to fluctuations depending on operational, material- and ambient-conditions! This must be considered during the selection!

Brake type	Thruuster type	*M _{Brmax.} (Nm) at $\mu = 0,4$	*M _{Brmin.} (Nm) at $\mu = 0,4^*$	*M _{Brmin.} (% from M _{Brmax.})	a _{max.}	b ₁	b ₂	c	d ₁	d ₂	e	f ca.	g	h	i	k	l _{max.}	m ca.	n	p	q	r	s ca.	kg ca.
EBN 200-23/5	Ed 23/5	265	172	65	510	75	70	96	200	15	160	115	90	155	55	145	665	185	100	70	100	12	1	40
EBN 200-30/5	Ed 30/5	350	193	55	563	75	70	96	200	15	160	115	90	155	55	145	670	185	100	70	100	12	1	46
EBN 200-50/6	Ed 50/6	545	354	65	573	75	70	96	200	15	195	115	90	155	55	145	710	185	100	70	100	12	1,2	53
EBN 250-23/5	Ed 23/5	310	217	70	518	95	90	115	250	19	160	135	100	185	65	180	790	215	105	95	105	14	1	46
EBN 250-30/5	Ed 30/5	450	225	50	581	95	90	115	250	19	160	135	100	185	65	180	795	215	105	95	105	14	1	52
EBN 250-50/6	Ed 50/6	705	529	75	590	95	90	115	250	19	195	135	100	185	65	180	835	215	105	95	105	14	1,2	59
EBN 250-80/6	Ed 80/6	1200	600	50	590	95	90	115	250	19	195	135	100	185	65	180	835	215	105	95	105	14	1,2	60
EBN 315-30/5	Ed 30/5	605	424	70	703	118	110	140	315	19	160	165	110	225	80	220	910	270	110	133	240	14	1	82
EBN 315-50/6	Ed 50/6	1000	600	60	705	118	110	140	315	19	195	165	110	225	80	220	990	270	110	133	240	14	1,2	89
EBN 315-80/6	Ed 80/6	1750	1313	75	705	118	110	140	315	19	195	165	110	225	80	220	990	270	110	133	240	14	1,2	90
EBN 315-121/6	Ed 121/6	2500	1250	50	705	118	110	140	315	19	240	165	110	225	80	220	980	270	110	133	240	14	1,2	102
EBN 400-50/6	Ed 50/6	1125	731	65	705	150	140	167	400	23	195	195	140	270	100	270	1095	315	135	165	280	15	1,4	105
EBN 400-80/6	Ed 80/6	1700	935	55	710	150	140	167	400	23	195	195	140	270	100	270	1095	315	135	165	280	15	1,4	106
EBN 400-121/6	Ed 121/6	2700	1755	65	710	150	140	167	400	23	240	195	140	270	100	270	1085	315	135	165	280	15	1,4	118
EBN 400-201/6	Ed 201/6	4000	2000	50	796	150	140	167	400	23	240	195	140	270	100	270	1085	315	135	165	280	15	1,4	121
EBN 500-50/6	Ed 50/6	1150	748	65	851	190	180	210	500	22	195	245	170	330	130	325	1280	390	155	210	315	20	1,5	161
EBN 500-80/6	Ed 80/6	1740	870	50	851	190	180	210	500	22	195	245	170	330	130	325	1280	390	155	210	315	20	1,5	162
EBN 500-121/6	Ed 121/6	3100	1705	55	851	190	180	210	500	22	240	245	170	330	130	325	1270	390	155	210	315	20	1,5	174
EBN 500-201/6	Ed 201/6	5120	2560	50	851	190	180	210	500	22	240	245	170	330	130	325	1270	390	155	210	315	20	1,5	177
EBN 630-121/6	Ed 121/6	3050	1525	50	995	236	225	250	630	27	240	300	220	410	170	400	1335	470	165	280	330	25	1,8	271
EBN 630-201/6	Ed 201/6	4950	2475	50	1015	236	225	250	630	27	240	300	220	410	170	400	1335	470	165	280	330	25	1,8	274
EBN 630-301/6	Ed 301/6	6025	3012	50	1015	236	225	250	630	27	240	300	220	410	170	400	1335	470	165	280	330	25	1,8	266
EBN 710-121/6	Ed 121/6	3450	1725	50	1110	265	255	280	710	27	240	335	240	460	190	450	1495	520	250	250	450	25	1,8	346
EBN 710-201/6	Ed 201/6	5600	2800	50	1110	265	255	280	710	27	240	335	240	460	190	450	1495	520	250	250	450	25	1,8	349
EBN 710-301/6	Ed 301/6	6920	3460	50	1110	265	255	280	710	27	240	335	240	460	190	450	1495	520	250	250	450	25	1,8	341

Enclosures

For drum brakes type EBN – Dimensions and executions



Rev. 04-18

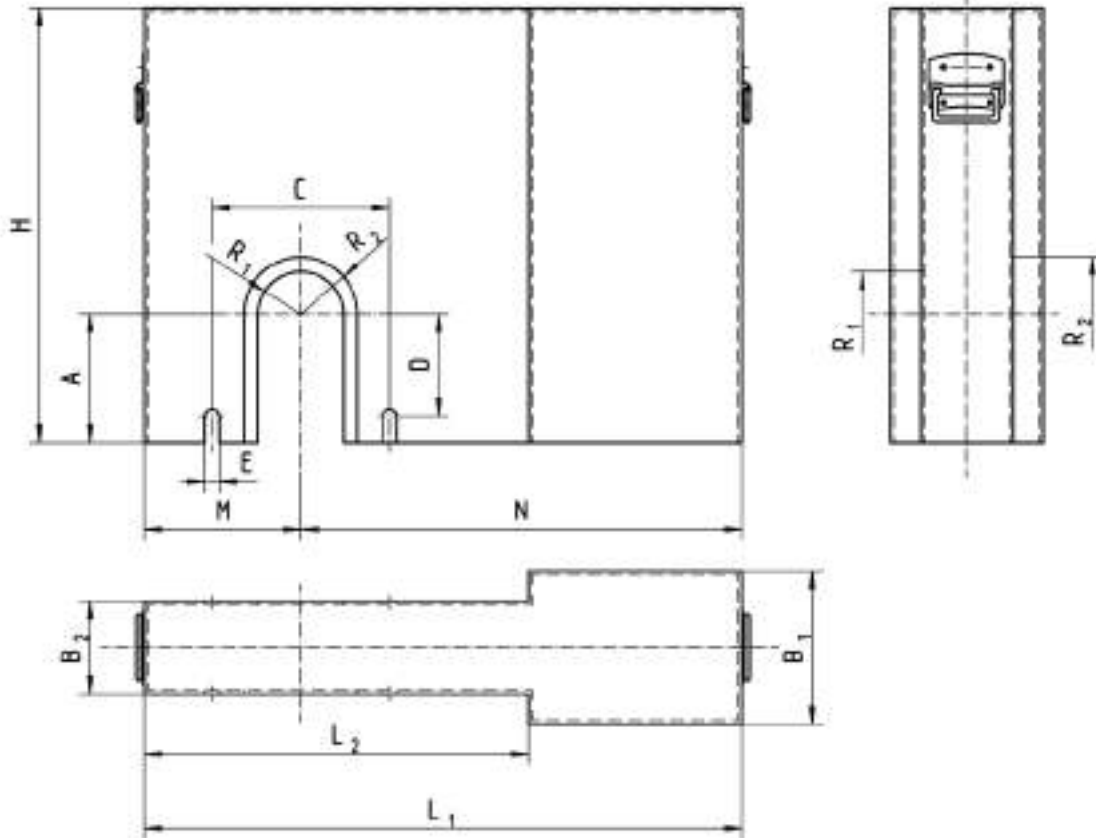

Plate thickness = 1,5 mm
 All enclosures are provided with handles
 Other dimensions upon request

All dimensions in mm
 Alterations reserved without notice

Brake type	A	B ₁	B ₂	C	D	E	H	L ₁	L ₂	M	N	R _{max.}
EBN 200-23/5	150	180	130	200	118	10	530	690	460	195	495	90
EBN 200-30/5	150	180	130	200	118	10	530	690	460	195	495	90
EBN 200-50/6	150	215	130	200	118	10	580	730	440	195	535	90
EBN 250-23/5	180	180	130	250	143	10	530	810	560	220	590	110
EBN 250-30/5	180	180	130	250	143	10	610	810	560	220	590	110
EBN 250-50/6	180	215	130	250	143	10	610	840	540	220	620	110
EBN 250-80/6	180	215	130	250	143	10	610	840	540	220	620	110



When ordering please advise: Brake type, Dimension "R₁ and R₂".

Enclosures

For drum brakes type EBN – Dimensions and executions



Rev. 04-18

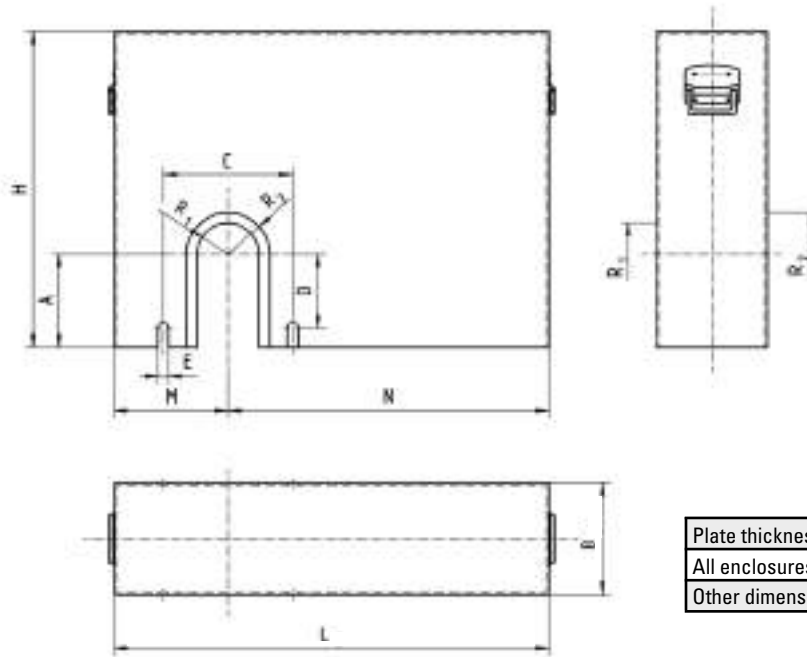

Plate thickness = 1,5 mm
 All enclosures are provided with handles
 Other dimensions upon request

All dimensions in mm
 Alterations reserved without notice

Brake type	A	B	C	D	E	H	L	M	N	R _{max.}
EBN 200-23/5	150	180	200	118	10	530	690	195	495	90
EBN 200-30/5	150	215	200	118	10	530	690	195	495	90
EBN 200-50/6	150	215	200	118	10	580	730	195	535	90
EBN 250-23/5	180	180	250	143	10	530	810	220	590	110
EBN 250-30/5	180	180	250	143	10	610	810	220	590	110
EBN 250-50/6	180	215	250	143	10	610	840	220	620	110
EBN 250-80/6	180	215	250	143	10	610	840	220	620	110
EBN 315-30/5	220	180	315	179	12	700	920	280	640	140
EBN 315-50/6	220	215	315	179	12	700	1000	280	720	140
EBN 315-80/6	220	215	315	179	12	700	1000	280	720	140
EBN 315-121/6	220	260	315	179	12	830	1000	280	720	140
EBN 400-50/6	260	215	400	205	12	710	1100	320	780	180
EBN 400-80/6	260	215	400	205	12	710	1100	320	780	180
EBN 400-121/6	260	260	400	205	12	830	1100	320	780	180
EBN 400-201/6	260	260	400	205	12	830	1100	320	780	180
EBN 500-50/6	320	280	500	260	12	900	1280	400	880	230
EBN 500-80/6	320	280	500	260	12	900	1280	400	880	230
EBN 500-121/6	320	280	500	260	12	900	1280	400	880	230
EBN 500-201/6	320	280	500	260	12	900	1280	400	880	230
EBN 630-121/6	400	280	630	325	14	1080	1350	470	880	290
EBN 630-201/6	400	280	630	325	14	1080	1350	470	880	290
EBN 630-301/6	400	280	630	325	14	1080	1350	470	880	290
EBN 710-121/6	450	320	710	370	14	1150	1530	530	1000	330
EBN 710-201/6	450	320	710	370	14	1150	1530	530	1000	330
EBN 710-301/6	450	320	710	370	14	1150	1530	530	1000	330



When ordering please advise: Brake type, Dimension "R₁ and R₂".

Flexible Coupling Type K

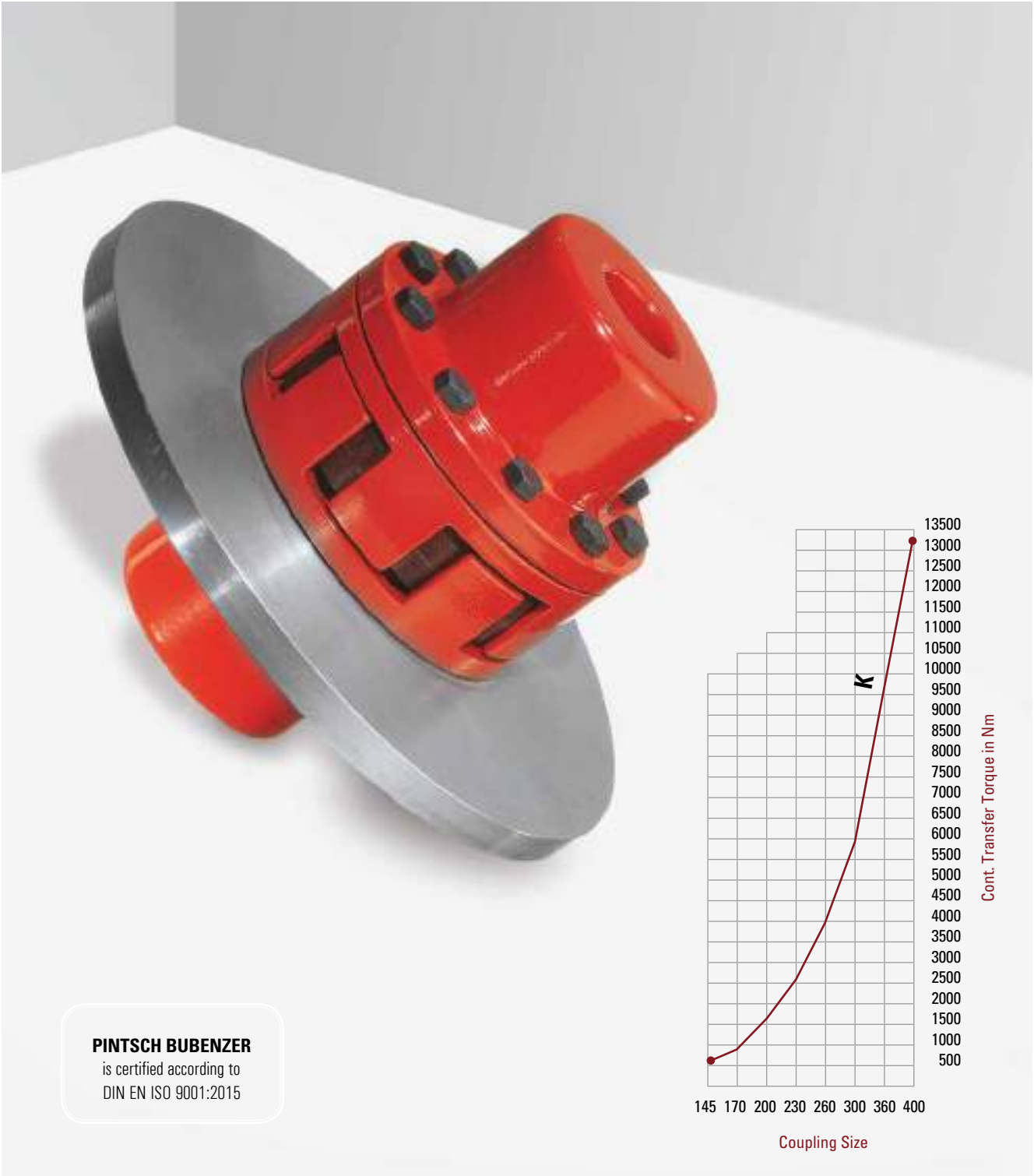

PINTSCH BUBENZER
is certified according to
DIN EN ISO 9001:2015



Torsionally Elastic



Tried and Trusted



High Performance



Robust



Easy Maintenance

Description Coupling Type K



Main Features

Steel coupling, torsionally elastic and puncture-proof
Transmission of torque via elastic intermediate ring
Replacement of the elastic intermediate ring or the brake disc without disturbing any equipment
Arrangement of the brake disc on the load side to allow the brake torque to be maintained when the motor is disengaged
Extensive selection of coupling sizes and brake disc diameters to satisfy most braking and drive requirements

Options

Coupling hubs finish bored and keywayed acc. to DIN 6885
Coupling hubs unbored
Coupling hubs pilot bored
Coupling dynamically balanced according to ISO 1940 Grade: G 2.5; G 6.3
Coupling hubs in special lengths
Coupling hubs in special material
Test certificate DIN EN 10204-3.1

Ordering Example

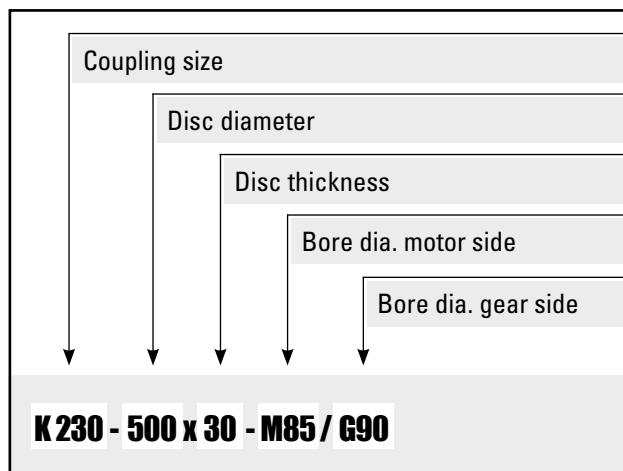

Applications

These couplings are for use in application with high dynamic loads
Damping of peak torques and vibrations as well as electrical insulation between motor and gearbox are further reasons for the use of this coupling type
The standard material of the elastic intermediate ring Polyurethane (Vulkollan) is suitable for a temperature range of -35°C up to +80°C. For a short time -40°C up to +100°C



Please Note

We supply a detailed operating manual with every order. Couplings are rotating parts and as such a cover must be fitted for the prevention of accidents.



PINTSCH BUBENZER Service

This includes the verification of the coupling selection, if required. A detailed questionnaire is provided for this purpose. Installation, commissioning and alignment by a laser system on site is possible by PINTSCH BUBENZER service engineers. Drawings as DWG/DXF files for your engineering department are available upon request.

Flexible Coupling Type K

Dimensions and technical data



Rev. 03-18
MB-001161 d

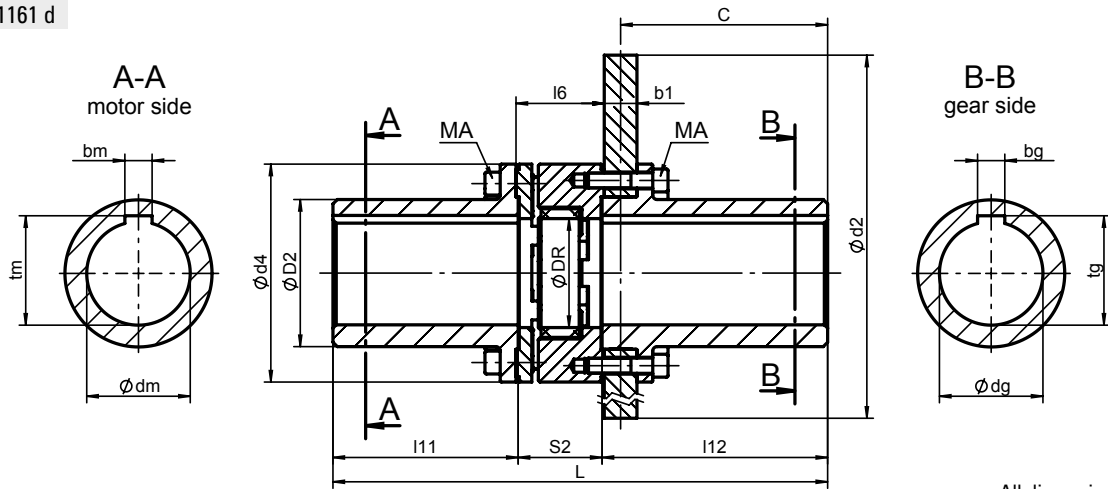

All dimensions in mm
Alterations reserved without notice

Coupling K (size = d_4)		145	170	200	230	260	300	360	400
$M_{Bmax.}$	Nm	1800	2850	4950	7740	11940	17550	29100	40050
T_{KN} (VK60D)	Nm	600	950	1650	2580	3980	5850	9700	13350
$n_{max.}$ at max. disc- \emptyset	min ⁻¹	3800	3400	3000	2700	2400	2200	1750	1750
d_m max. + d_g max.	mm	65	75	95	110	125	140	160	160
D_2	mm	92	110	135	160	180	200	225	225
D_R	mm	66	90	100	115	150	162	215	250
L	mm	344,5	374,5	454	458,5	518,5	535,5	627,5	627,5
l_{11}	mm	110	140	170	170	210	210	250	250
l_{12}	mm	166,5	166,5	207	207,5	212,5	212,5	252,5	252,5
l_6	mm	71 +2,5	71 +3	81 +3	86 +3,5	101 +4	118 +4	130 +4	130 +4
S_2	mm	68	68	77	81	96	113	125	125
C ($b_1 = 30$ mm / 40 mm)	mm	150 / -	150 / -	190 / -	190 / -	195 / -	195 / -	235 / 230	235 / 230
M_A (DIN 912-8.8; $\mu=0,12$)	Nm	84	84	132	132	206	410	710	710

Brake disc diameter $d_2 \times b_1$ (mm)	355 x 30	Weight of the coupling with steel brake disc							
	kg	Moment of inertia							
		41							
		0,3973							
	400 x 30		47	54	76				
			0,6219	0,656	0,801				
	450 x 30		55	62	84				
			0,9781	1,016	1,158				
	500 x 30			71	93	116	139		
				1,513	1,655	1,782	2,123		
	560 x 30				105	128	150		
					2,484	2,611	2,960		
	630 x 30					143	168	189	
						3,98	4,330	4,704	
	710 x 30						185	225	
							6,563	6,92	
	800 x 30							250	311
								10,52	11,49
	900 x 30								342
									17,21
	1000 x 30								376
									25,16
									354
									17,69
									389
									25,65

Weights and moments of inertia are not binding, referring to the max. finish bore for the sizes 145 to 300 respectively for a finish bore of 120 mm for the sizes 360 and 400.

Flexible Coupling Type K

Design and permissible misalignments



Rev. 11-16

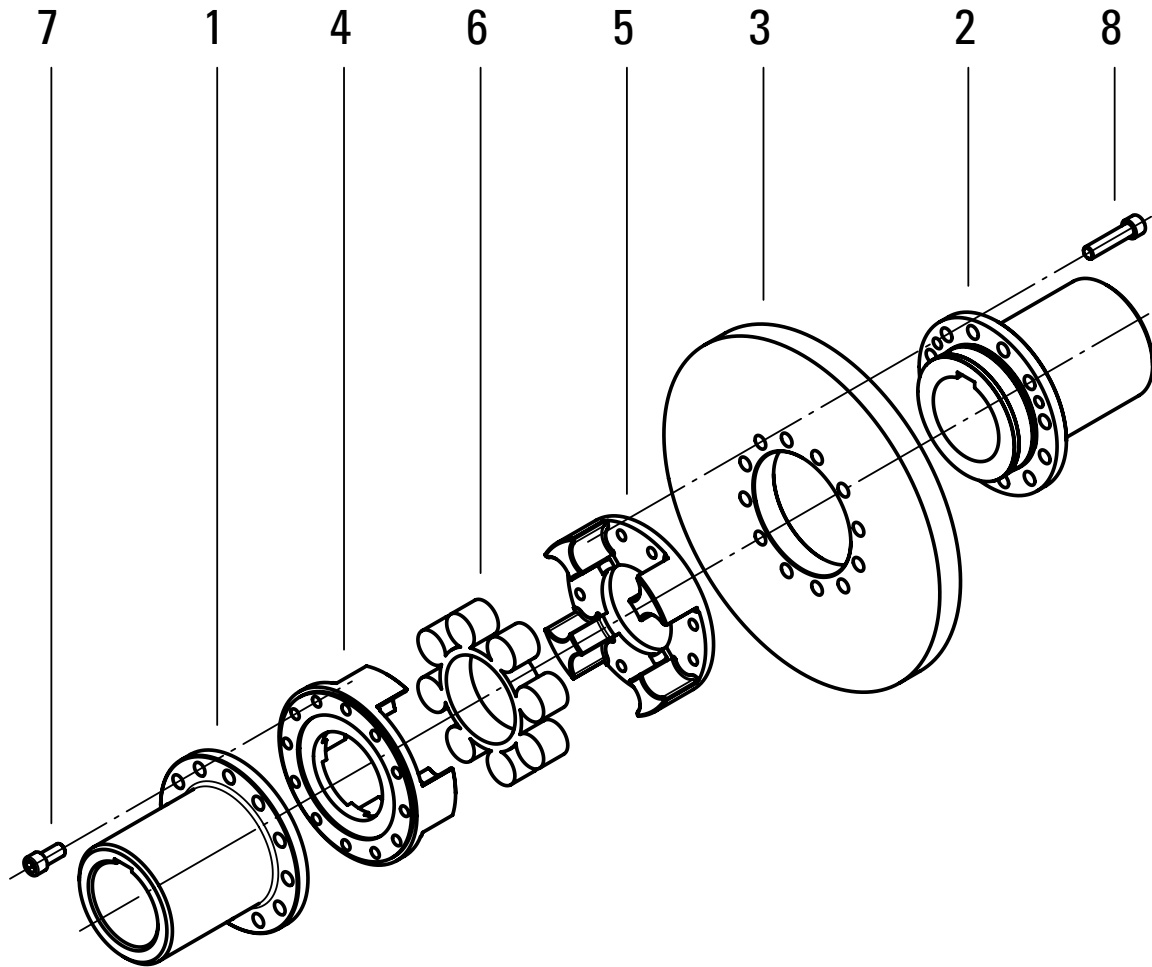

1	Hub, motor side
2	Hub, gear side
3	Brake disc
4	Claw ring, removable
5	Claw ring, removable
6	Elastic intermediate ring
7	Hexagon socket head screw
8	Hexagon socket head screw

Gear Coupling Type KBT

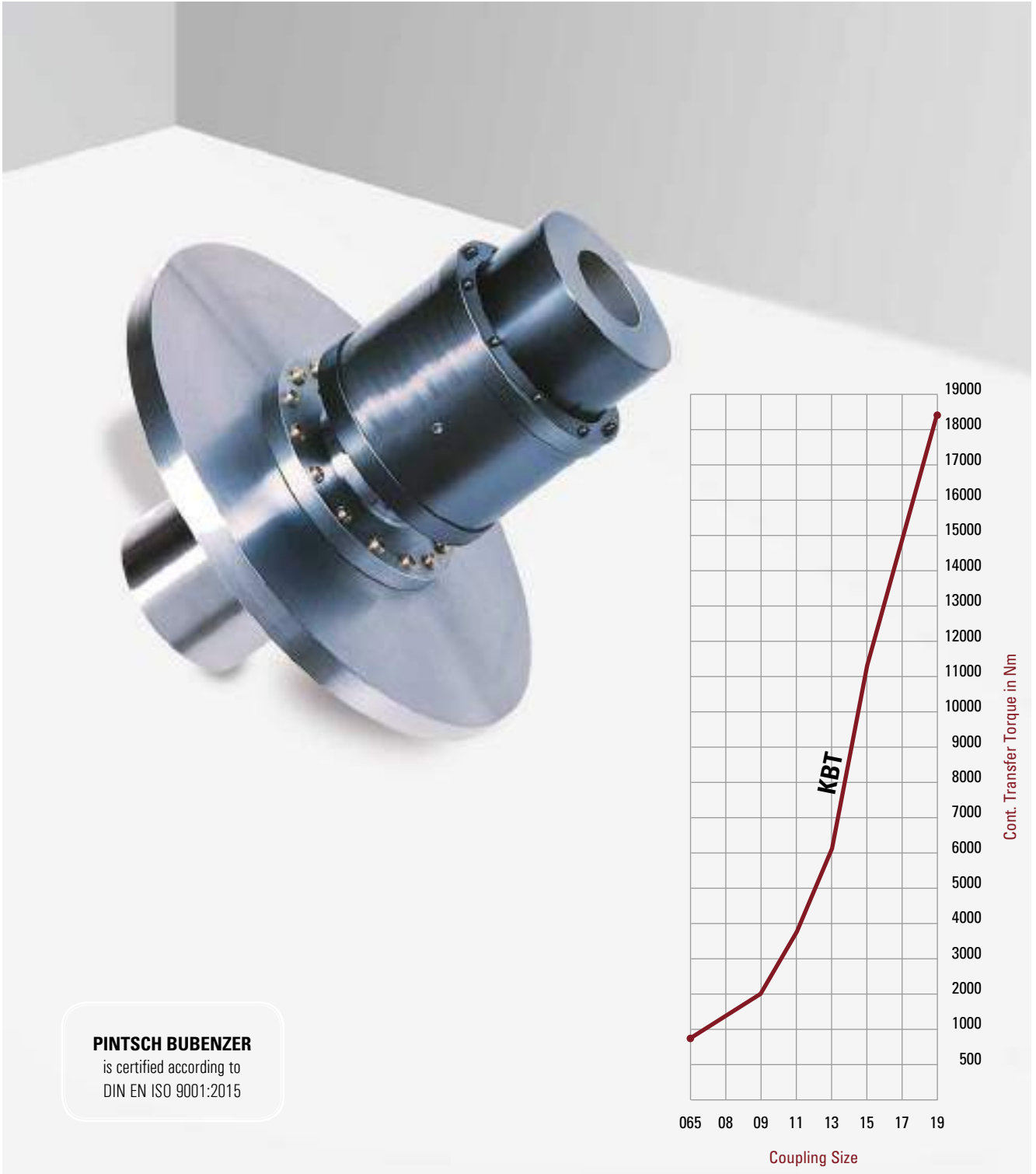

PINTSCH BUBENZER
is certified according to
DIN EN ISO 9001:2015

- 
Torsionally Rigid
- 
Tried and Trusted
- 
High Performance
- 
Robust
- 
Easy Maintenance

Description Coupling Type KBT



Main Features

Steel coupling with special formed teeth
Torque transmission via internal geared sleeve and external geared hubs
Replacement of the brake disc or the seals without disturbing any equipment
High temperature resistance
Low wear
Arrangement of the brake disc on the load side to allow the brake torque to be maintained when the motor is disengaged
Extensive selection of coupling sizes and brake disc diameters to satisfy most braking and drive requirements

Options

Coupling hubs finish bored and keywayed acc. to DIN 6885
Coupling hubs unbored
Coupling hubs pilot bored
Coupling dynamically balanced according to ISO 1940 Grade: G 2.5; G 6.3
Hubs in special dimensions
Hubs in special material
Test certificate DIN EN 10204-3.1

Applications

The design of these couplings makes them particularly suitable in machinery where a torsionally rigid torque transmission is required, especially on frequently varying loads and speeds

Ordering Example

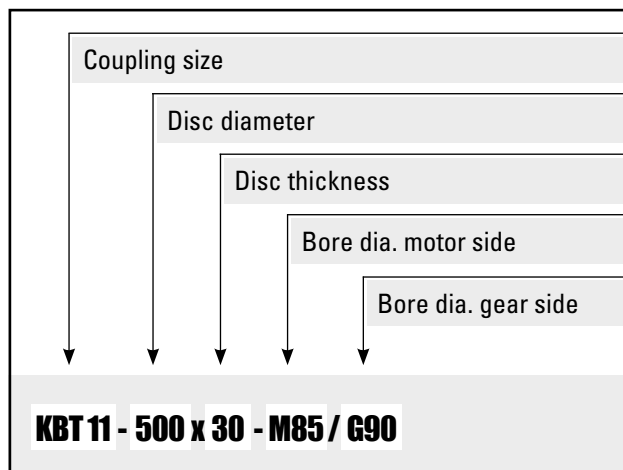

Attention

Special grease for high ambient temperatures!



Please Note

We supply a detailed operating manual with every order. Couplings are rotating parts and as such a cover must be fitted for the prevention of accidents.



PINTSCH BUBENZER Service

This includes the verification of the coupling selection, if required. A detailed questionnaire is provided for this purpose. Installation, commissioning and alignment by a laser system on site is possible by PINTSCH BUBENZER service engineers. Drawings as DWG/DXF files for your engineering department are available upon request.

Gear Coupling Type KBT

Dimensions and technical data



Rev. 09-02

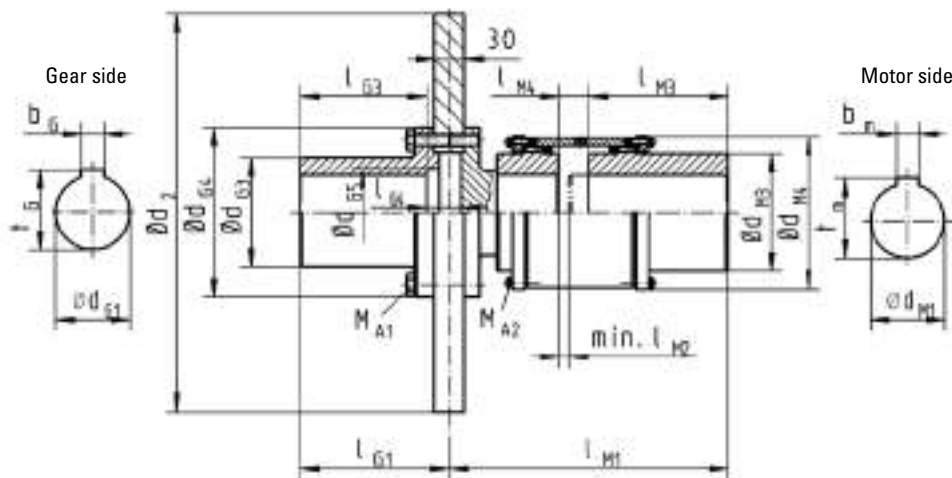

All dimensions in mm
Alterations reserved without notice

Coupling KBT		065	08	09	11	13	15	17	19
MBr max.	Nm	2000	4000	5000	9250	15250	27500	36500	46000
TKN	Nm	800	1600	2000	3700	6100	11000	14600	18400
n _{max} at max. disc Ø	min ⁻¹	3800	3400	2750	2400	2150	2150	1900	1900
dG1 max.	mm	55	75	90	110	120	140	160	195
dG3	mm	85	110	130	160	180	200	225	265
dG4	mm	145	170	200	230	260	300	360	400
dG5	mm	68	88	105	130	140	162	184	225
dM1 max.	mm	70	85	95	110	130	155	175	195
dM3	mm	100	118	130	151	178	213	235	263
dM4	mm	140	154	161	186	216	254	282	317
lG1	mm	150	150	190	190	195	195	235	235
lG3	mm	127	127	167	167	172	172	212	212
lG4	mm	35	35	35	35	35	35	35	35
lM1	mm	215	280	310	325	350	385	425	470
lM2	mm	7	10	10	10	10	10	10	10
lM3	mm	110	140	146	165	170	190	200	220
lM4	mm	12	30	17	19	23	24	29	32
Brake disc diameter d ₂ x b ₁ (mm)	355 x 30	43			Weight of the coupling with				kg
		0,415			Moment of inertia of the coupling with				kgm ²
	400 x 30	49	62	79					
		0,639	0,73	0,752					
	450 x 30	57	70	87					
		0,996	1,09	1,108					
	500 x 30		79	96	119				
			1,585	1,605	1,783				
	560 x 30			108	131	161			
				2,434	2,611	2,915			
630 x 30			123	146	176	229			
			3,802	3,98	4,283	4,955			
710 x 30				166	196	248	310	393	
				6,213	6,516	7,118	8,351	10,23	
800 x 30					221	274	335	418	
					10,11	10,78	11,94	13,83	
900 x 30	Weights and moments of inertia are not binding, referring to the max. finish bore.							367	450
								17,64	19,53

Gear Coupling Type KBT

Design and permissible misalignments



Rev. 05-17

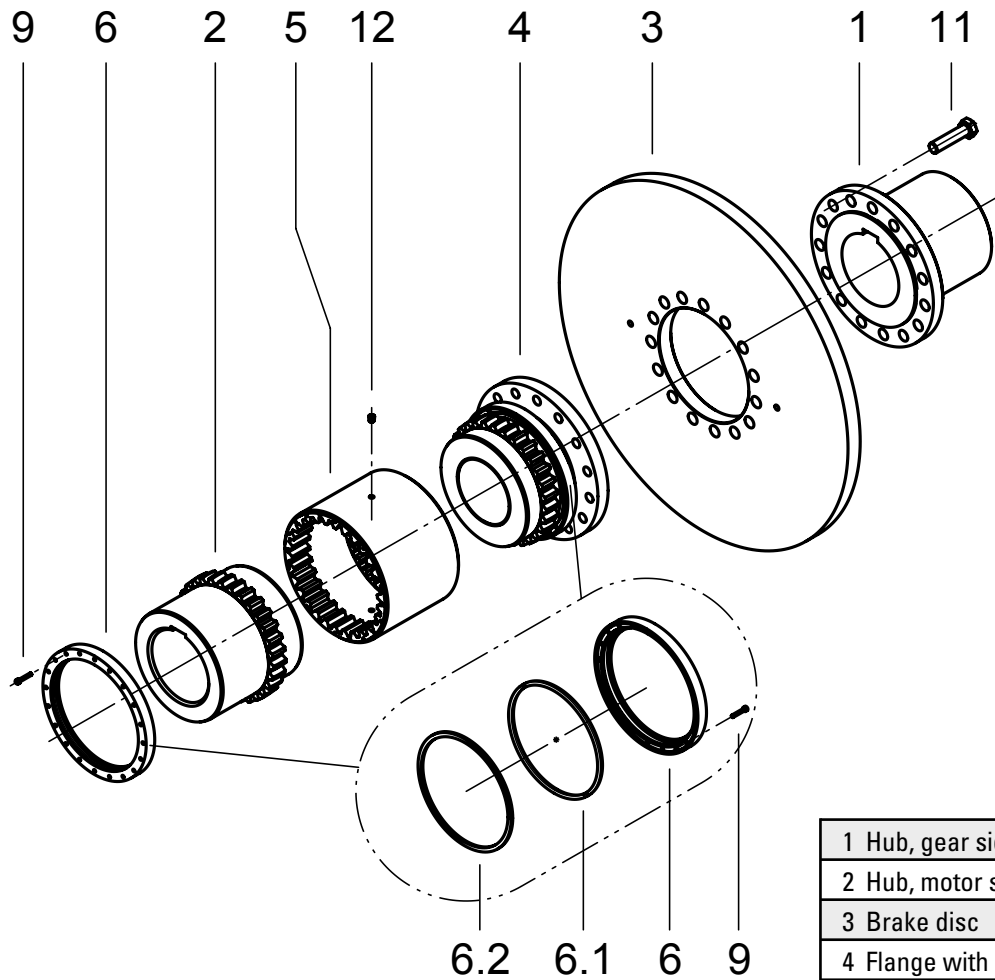

1	Hub, gear side
2	Hub, motor side
3	Brake disc
4	Flange with geared hub
5	Internal geared sleeve
6	Seal carrier with O-ring (6.1) and seal (6.2)
9	Hexagon socket head screw
11	Hexagon bolt
12	Screw plug

Hub with Brake Disc Type N + NX

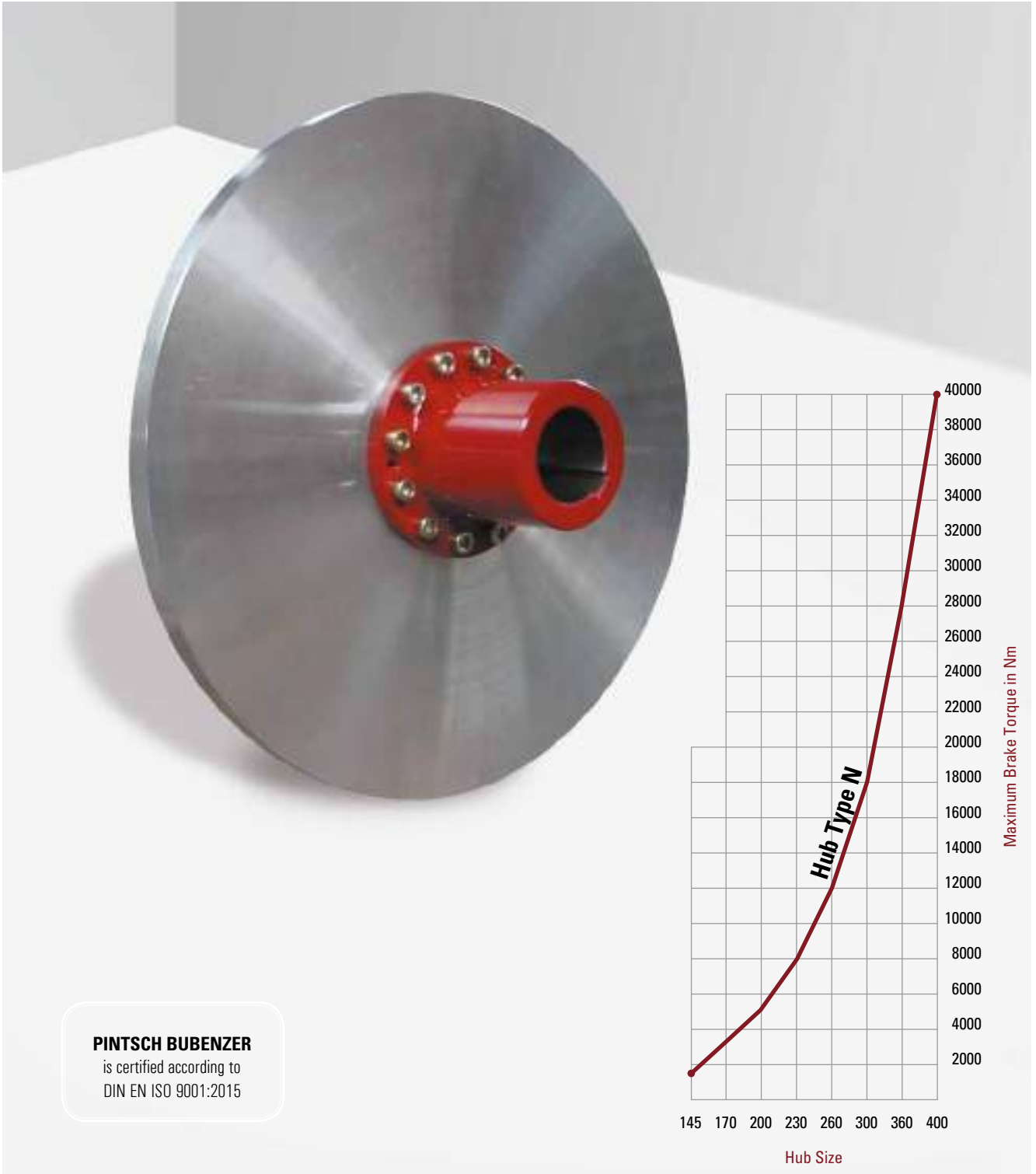

PINTSCH BUBENZER
is certified according to
DIN EN ISO 9001:2015

-  Safe
-  Tried and Trusted
-  Robust
-  Easy Maintenance

Description Hub Type N + NX



Main Features

- Three-piece hub-disc combination for easy exchange of brake disc (type N)
- High accident prevention by fastening ring, no rotating nuts (type N)
- Exchange of brake disc without removing the hub (type N)
- Simple, one-piece construction with 20 mm brake disc thickness for SB17 series brakes (type NX)

Options

- Hubs finish bored and keywayed acc. to DIN 6885
- Hubs unbored
- Hubs pilot bored
- Hubs with brake disc, dynamically balanced according to ISO 1940 Grade: G 2.5; G 6.3
- Hubs in special dimensions
- Hubs in special material
- Test certificate DIN EN 10204-3.1

Ordering Example

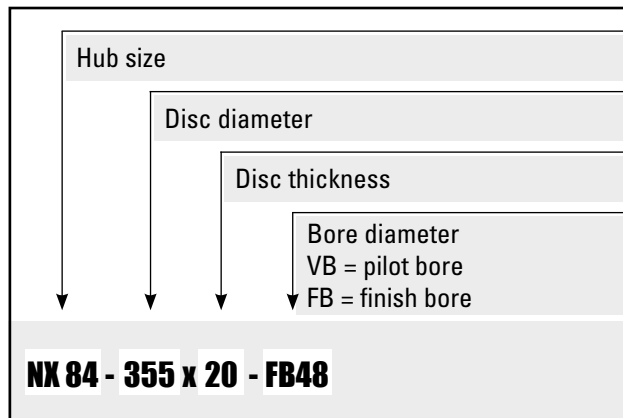

Ordering Example

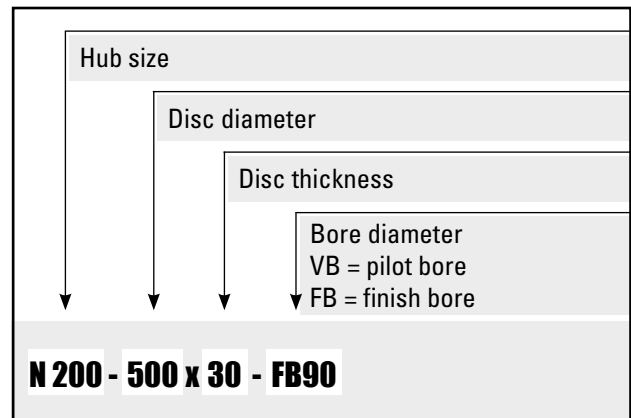

Applications

All drives, where the brake is not located between motor and gearbox, like brake location on the second gear box shaft or at the motor end shaft



Please Note

We supply a detailed operating manual with every order. Hubs with brake discs are rotating parts and as such a cover must be fitted for the prevention of accidents.



PINTSCH BUBENZER Service

This includes the verification of the hub selection, if required. A detailed questionnaire is provided for this purpose. Installation and commissioning on site is possible by PINTSCH BUBENZER service engineers. Drawings as DWG/DXF files for your engineering department are available upon request.

Hub with Brake Disc Type N

Dimensions and technical data



Rev. 12-06

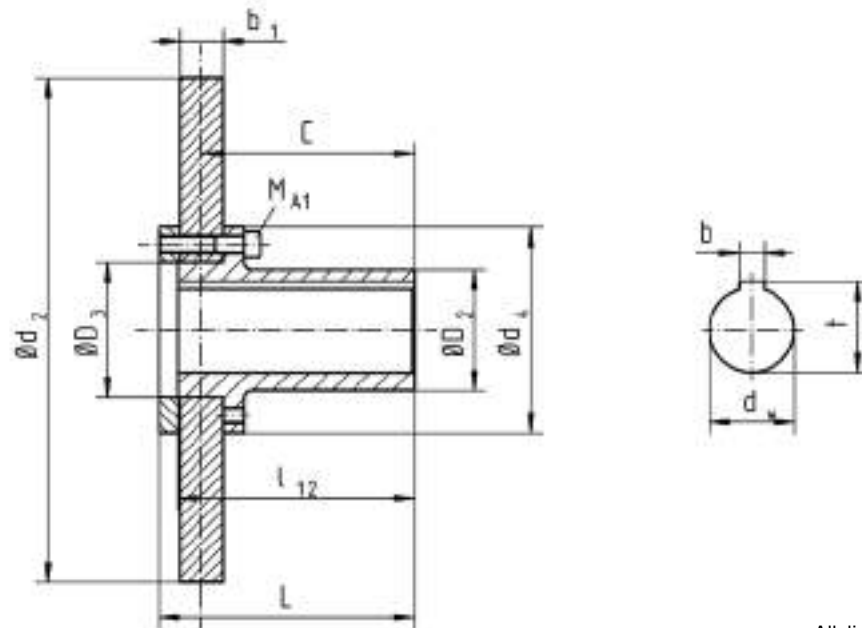

All dimensions in mm
Alterations reserved without notice

Hub N (size = d4)		145	170	200	230	260	300	360	400
MBr max.	Nm	1800	2850	4950	7740	11940	17550	29100	40050
nmax at max. disc Ø	min ⁻¹	3800	3400	3000	2700	2400	2200	1750	1750
dW max.	mm	60	75	95	110	125	140	160	160
D2	mm	85	110	135	160	180	200	225	225
D3	mm	95	120	140	170	200	220	260	300
L	mm	180	180	220	220	230	230	275	275
l12	mm	166,5	166,5	207	207,5	212,5	212,5	252,5	252,5
C	mm	150	150	190	190	195	195	235*	235*
MA	Nm	84	84	132	132	206	410	710	710
Brake disc diameter d2 x b1 (mm)	355 x 30	28			Weight		of the hub with		kg
		0,378			Moment of inertia		brake disc		kgm ²
	400 x 30	35	37	44					
		0,603	0,612	0,653					
	450 x 30	42	45	52					
		0,959	0,973	1,011					
	500 x 30		54	60	67	77			
			1,469	1,506	1,571	1,682			
	560 x 30			72	79	89			
				2,335	2,399	2,51			
	630 x 30				95	105	109		
					3,768	3,879	4,081		
710 x 30					124	128			
					6,112	6,213			
800 x 30	Weights and moments of inertia are not binding, referring to the max. finish bore for the sizes 145 to 300 respectively for a finish bore of 120 mm for the sizes 360 and 400.						153	189	
900 x 30							9,808	10,456	
								221	232
1000 x 30								16,123	16,473
								257	267
							24,075	24,424	

Hub with Brake Disc Type NX

Dimensions and technical data



Rev. 12-06

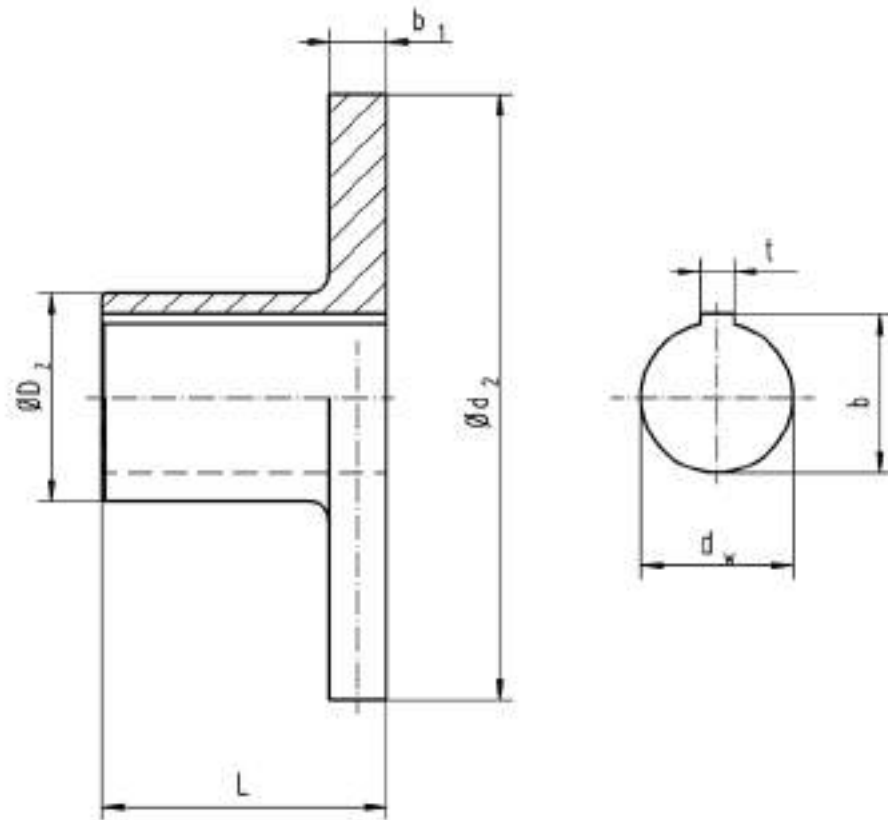

* Higher speeds possible by using sintered linings

All dimensions in mm
Alterations reserved without notice

Hub NX (size = D2)			58	64	74	84	92	100	114	
L mm			80	110	110	110	140	140	140	
dW max. mm			38	42	48	55	60	65	70	
		nmax. min ⁻¹ *	Thermal capacity kW							
Brake disc diameter d ₂ x b ₁ (mm)	200 x 20	3500	344	5,6	6,2	Weight of the hub with brake disc				kg
				0,025	0,026	Moment of inertia				kgm ²
	225 x 20	3300	399	7,0	7,5	8,1	8,6	9,3	10,9	
				0,040	0,040	0,041	0,042	0,045	0,047	
	250 x 20	3000	474	8,5	9,0	9,6	10,1	10,8	12,4	14,0
				0,060	0,061	0,062	0,063	0,066	0,067	0,072
	280 x 20	2675	567	10,5	11,0	11,6	12,2	13,0	14,5	16,2
				0,095	0,096	0,096	0,097	0,100	0,102	0,107
	315 x 20	2380	653	13,2	13,7	14,3	14,9	15,5	17,1	18,7
				0,153	0,153	0,153	0,154	0,157	0,159	0,164
	355x 20	2100	752		17,0	17,6	18,2	18,9	20,5	22,2
					0,246	0,246	0,274	0,250	0,252	0,257
	400 x 20	1875	863		21,0	21,6	22,2	22,8	24,4	26,0
					0,396	0,396	0,397	0,400	0,402	0,407
450 x 20	1650	986			27,0	27,7	28,4	30,0	31,7	
					0,634	0,635	0,637	0,639	0,645	
500 x 20	1500	1100			33,0	33,7	34,4	36,0	37,7	
					0,956	0,966	0,969	0,970	0,976	

Monitoring System VSR2-SB/CMB2-SB

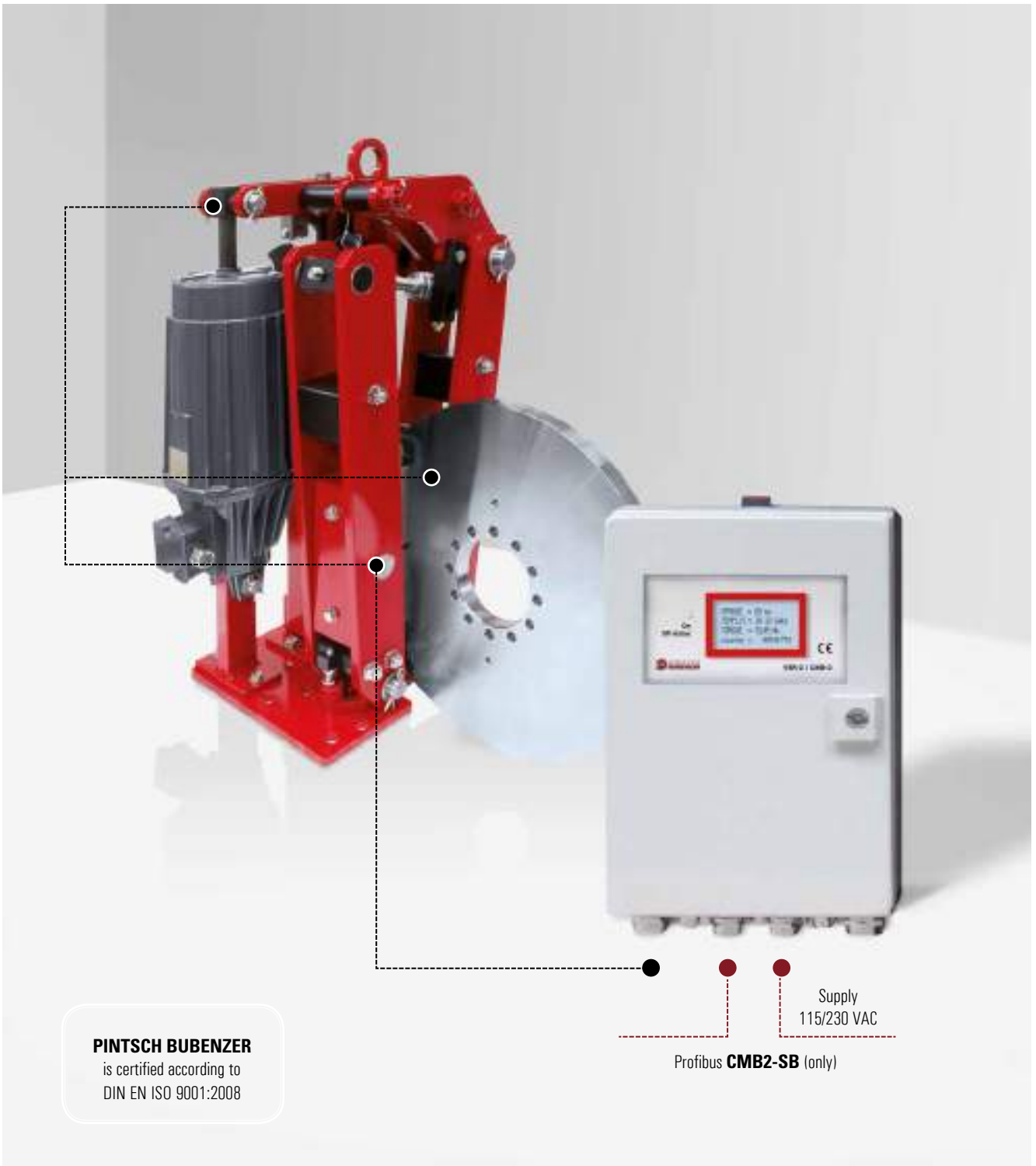

PINTSCH BUBENZER
is certified according to
DIN EN ISO 9001:2008

Supply
115/230 VAC
Profibus **CMB2-SB** (only)

Visual indication of			
thruster stroke < 5 mm > 20 mm < 55 mm	maximum brake pad temperature	air gap difference between disc and pad surface by measuring the temperature difference between pads caused by unilateral pad rubbing	pad thickness < 5 mm

Description VSR2-SB/CMB2-SB



In response to requirements to simplify the maintenance of industrial brakes and at the same time to increase their operational safety, PINTSCH BUBENZER offers a retrofitable, compact electronic status indication system to be integrated into the brake as an additional safety device

Main Features

- Industrial display with 4 rows of 20 characters for indication of measurement data and error messages
- High ambient temperature range – 20°C.....+70°C
- Protection class IP66
- Internal keypad for parameter change
- Up to 5 m cable length from sensor to electronic box. (Option)
- Brake operation cycle counter (up to 100 Mio. Cycles)
- Supply voltage selection switch 115/230 V AC
- One common error relay contact (VSR2-SB only)
- Profibus (CMB2-SB only). All scaled measures signals and error bits are transferred by bus system to the main control PLC. No analogue inputs in control PLC are required
- Option RPM speed sensor available
- Option: Stainless steel electronic box IP66 for outdoor use

Common parts for VSR2-SB and CMB2-SB

- Supply voltage: The electronic unit can be connected directly to 110-240 VAC supply voltage. The internal voltage selector switch must be set by the user to the corresponding position 115 or 230 V
- Temperature sensor: A pair of Pt100 sensors (B) measures the temperature of the each brake pad. If the temperature is too high or if the temperature is unequal from left to right side the unit generates a signal that is displayed in the panel. This reflected to the main control plc if the CMB2-SB unit is added
- Pad wear sensor: If the minimum brake pad thickness is reached, the sensors (A) send a signal to the electronic box
- Display: All measured analogue and digital signals and error messages are shown on the display in English language. Other languages are available on request. The display is readable under direct sunshine and has a LED backlight for use in a dark environment, such as steel mills.
- Keypad: With the internal key pad, the user can adjust parameters such as changing the temperature display from Celsius (°C) to Fahrenheit (°F) or setting of the Profibus address
- Reset button: The LED pushbutton on top of the electronic box indicates a wrong brake adjustment by a flashing red light. After the problem on the brake is solved, the status of the VSR2-SB / CMB2-SB can be reset to normal operation by pushing the button.
- Proximity switch release control: This switch and the optional manual release switch are independent from the VSR2-SB/ CMB2-SB and have to be connected to the control plc

Monitoring System VSR2-SB/CMB2-SB

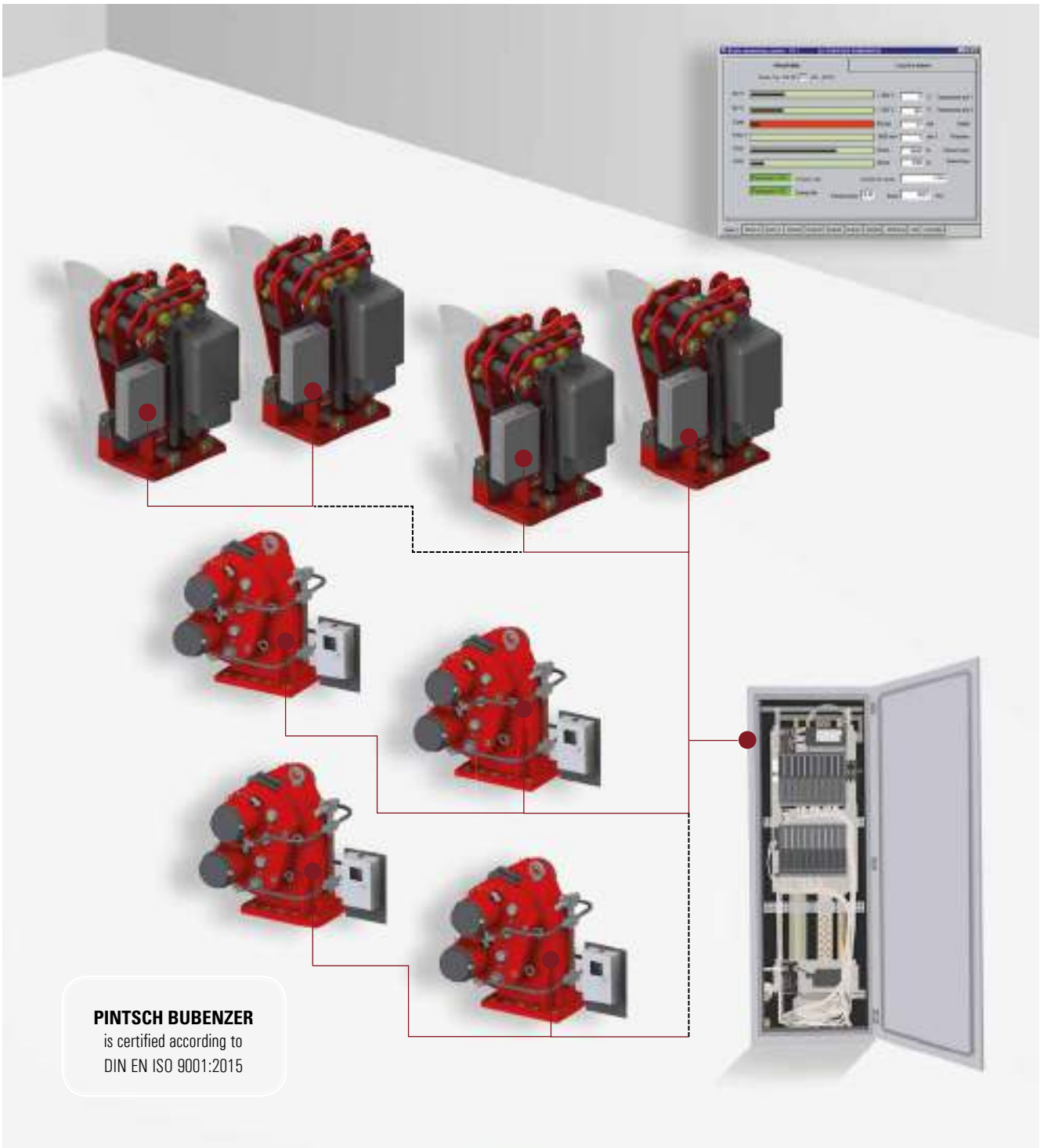

Permanent monitoring of



Thruster Stroke



Contact Force
Brake Force

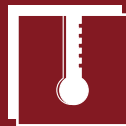

Lining
Temperature



Lining Wear



Disc Speed
(optional)

Description VSR2-SB/CMB2-SB



VSR2-SB parts

Stroke sensor: A digital stroke sensor detects an Eldro reserve stroke <5mm or larger than 15 mm

Relay contact: A dry contact (max 250 V 2 A) is connected to terminals 21/22. It is closed in normal status of the VSR2-SB and open, if the system is in error mode, or switched off

CMB2-SB parts

Stroke sensor: The digital stroke sensor of the VSR-SB is replaced by an analogue sensor that measures the position of the thruster piston rod. The reserve stroke is measured and checked that it is at the perfect position of 10 mm with the brake is completely released. The maximum measurement range is 100 mm. The digital sensor is still available as an option

Force sensor: One load cell pin, located in the brake shoe, measures the contact force in the closed condition of the brake. This signal is used to detect an incorrect or broken spring setting. The signal "contact force" (max. 70 kN) is converted in software to the equivalent torque value in Nm. So the displayed value in Nm can be easily compared with the torque value shown on the spring scale

Disc speed RPM sensor: For this option, a special brake disc with marks is needed. A proximity sensor counts the impulses per time period and the RPM value is calculated

Profibus: All measured data (scaled) and warning signals are transferred by the Profibus-DP port to the main control PLC. No expensive analogue inputs (6 pc per brake) are required in the main PLC. The address of the DP slave can be easily set in the electronic box by a parameter change in the software . Up to 126 brakes can be connected to one Profibus master on the main PLC

Signals from brake to main PLC



Please Note

All these readings are logged by the CMB unit and transmitted for visualization. Visualization of sensor output can be provided by a stand-alone PC system or by combining the CMB with an existing crane operating / visualization system (e.g. via Profibus).

Monitoring System VSR2-SB/CMB2-SB

Dimensions and technical data



Rev. 12-06

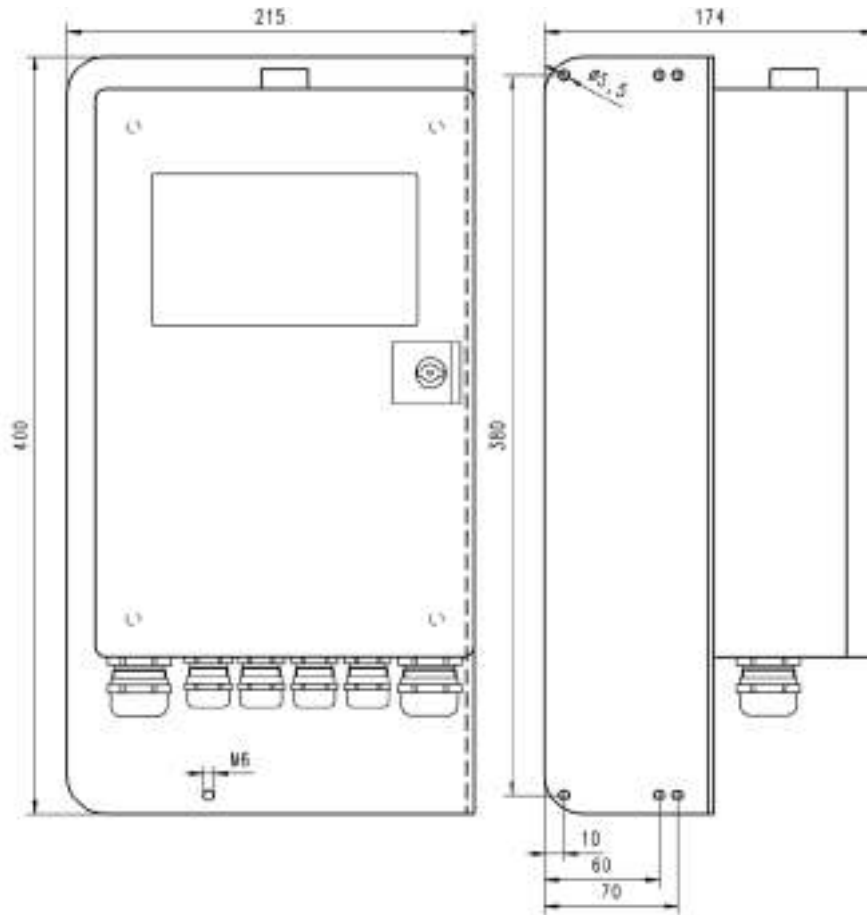

Cable glands wired by PB:

- M25: Padwear1, Padwear2, Stroke, Force
- M12: Temperature 1
- M20: Release, Manual Release
- M20: Speed, Temperature 2
- M12: spare

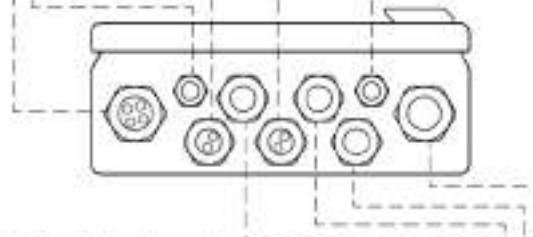

Cable glands for customer:

- M20: Profibus In, max cable diameter 13 mm
- M20: Profibus Out, max cable diameter 13 mm
- M20: Supply voltage, max cable diameter 13 mm
- M25: Signals to crane, max cable diameter 17 mm

Remark: Force, Profibus In and Out only for CME2

Monitoring System VSR2-SB/CMB2-SB

Dimensions and technical data



Rev. 09-02

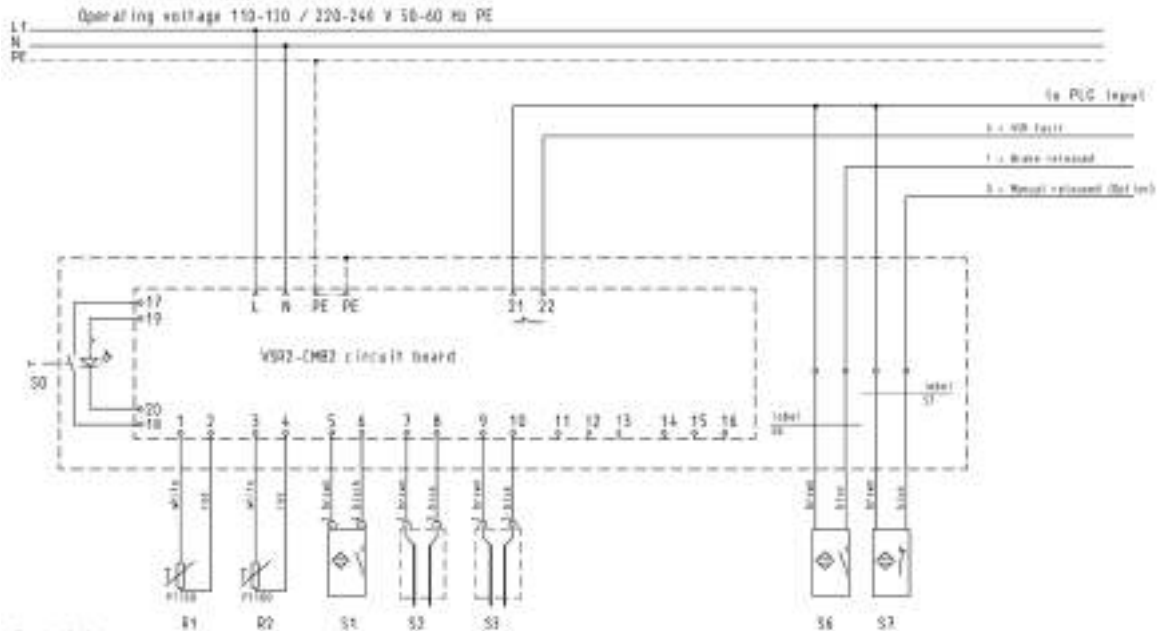

Part list:

- S0 Reset button with LED lamp
- R1 Brake pad 1 temperature sensor
- R2 Brake pad 2 temperature sensor
- S1 Stroke sensor
- S2 Pad 1 wear sensor

- S3 Pad 2 wear sensor
- S6 Proximity switch brake release control 20-240 V AC/DC
- S7 Proximity switch hand release control 20-240 V AC/DC (Option)

VSR2-SB Version

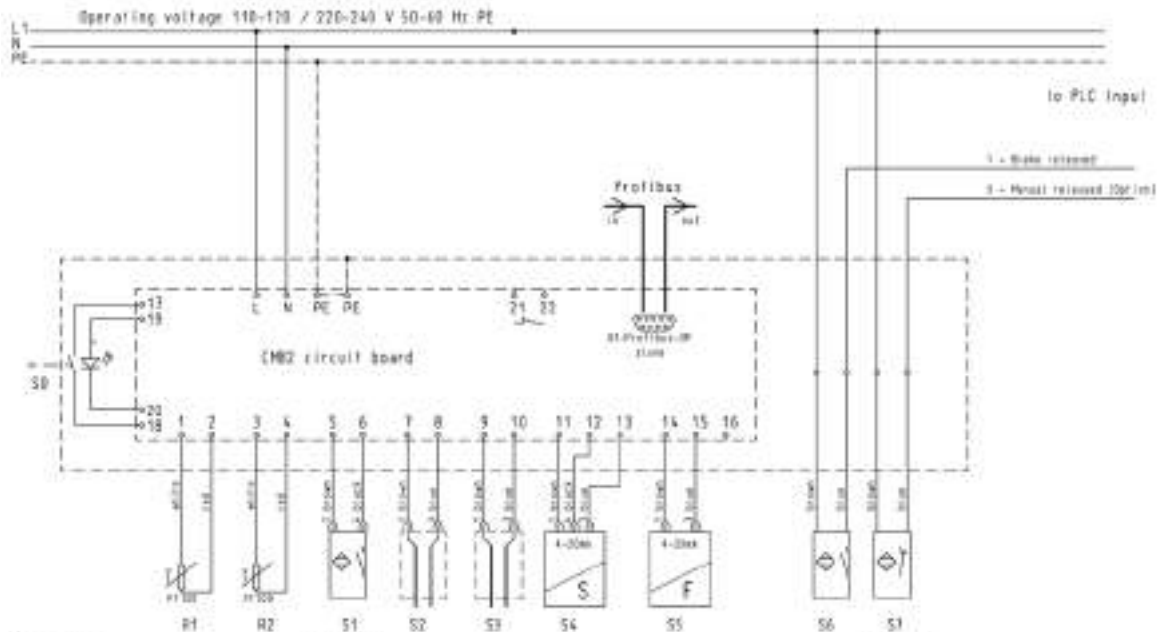

Part list:

- S0 Reset button with LED lamp
- R1 Brake pad 1 temperature sensor
- R2 Brake pad 2 temperature sensor
- S1 Speed sensor (Option)
- S2 Pad 1 wear sensor

- S3 Pad 2 wear sensor
- S4 Analog stroke sensor
- S5 Contact force sensor
- S6 Proximity switch brake release control 20-240 V AC/DC
- S7 Proximity switch hand release control 20-240 V AC/DC

CMB2-SB Version

Brake Control System BB 900

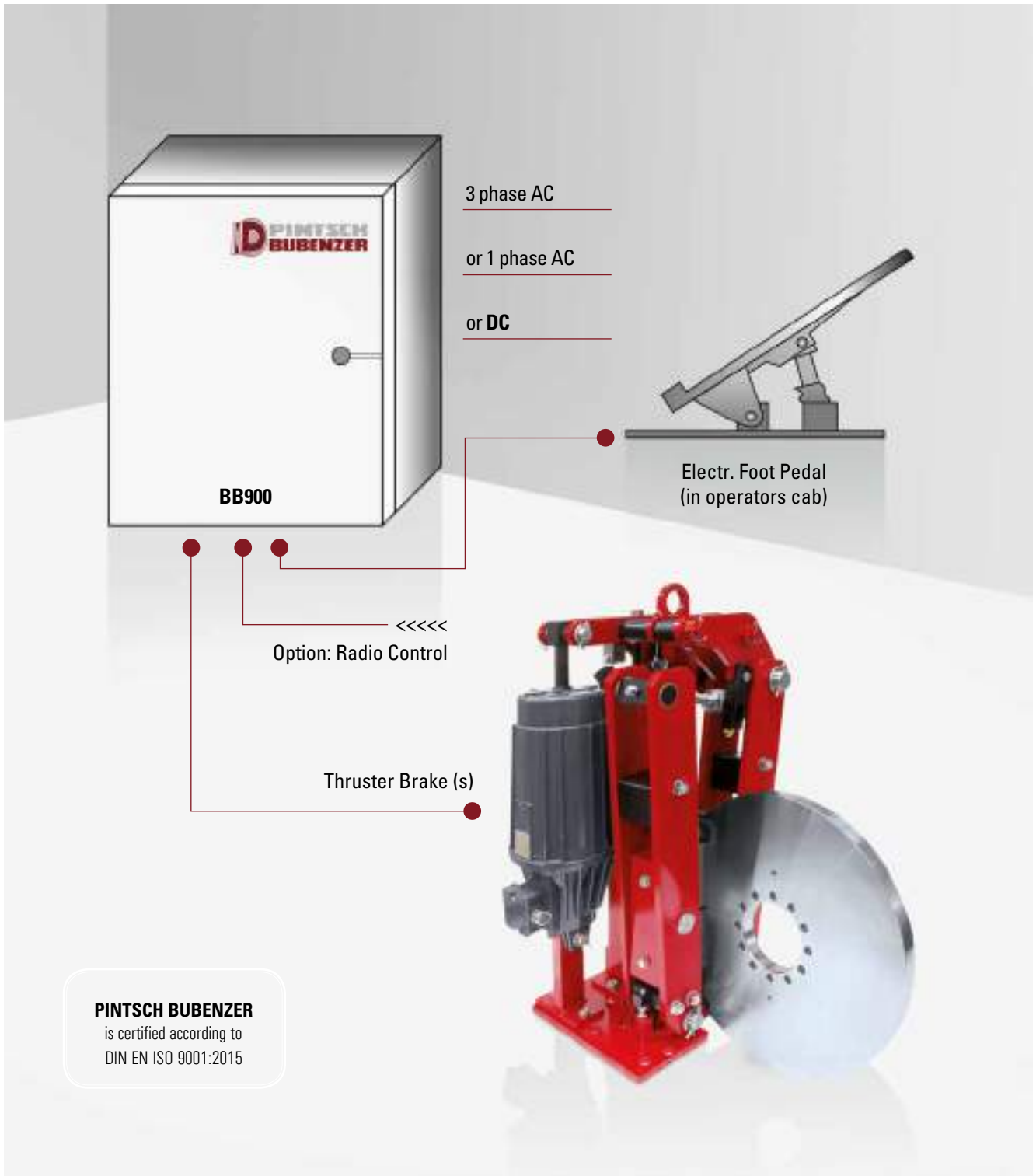

Controlled
Braking



Simple
Installation



Retrofitable



Brake Remains
Failsafe!



Use of AC Thrusters
in DC Systems!

Description BB 900



Version 0

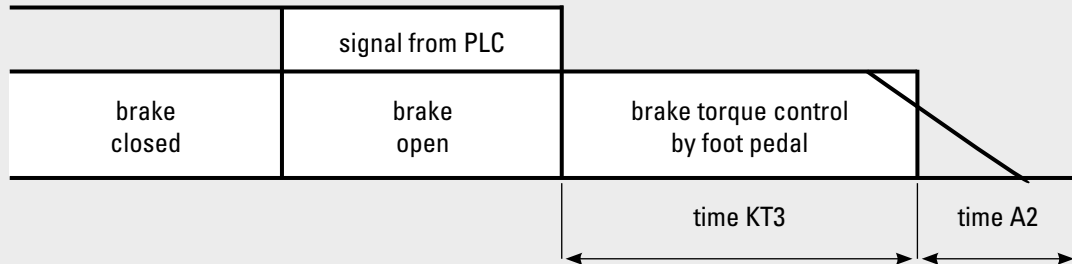

Version 1

Foot pedal with two limit switches. Actuation of the foot pedal switches off the drive motor and allows braking control with the pedal. When the pedal is depressed to the full extent, the brake remains closed until the customer's master switch is actuated once more.

Version 2

Two operating modes, accessed by the customer's selector switch.

1. Direct opening and closing of the brake without time delay.
2. Direct opening of the brake; Closing of the brake with adjustable time delay. During this time delay, braking can be carried out by the foot pedal.

Version 3

Customer's current (4...20 mA) or voltage signal (0...10 V) for the stepless control of the brake torque (without foot pedal)

All frequency converter units as standard with:

Steel enclosure for use under harsh environmental conditions (600x600x210mm).

Main power input filter for filtering out main disturbances.

Filter for reducing voltage spikes of the electro-hydraulic brake thrusters and eliminating EMV problems.

Board for connection of the standard PINTSCH BUBENZER foot pedal with inductive coil.

Ordering Example

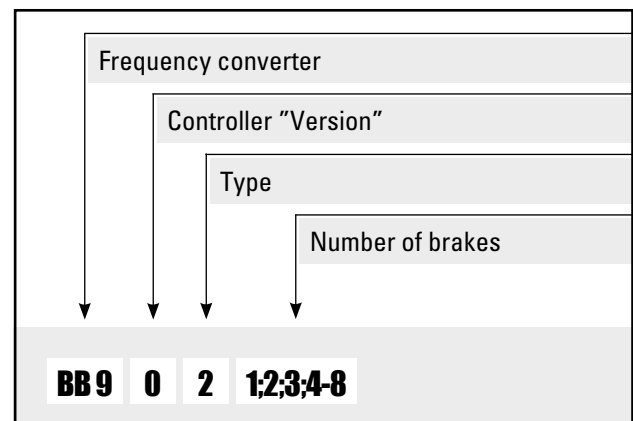

Monitoring System CMB2-SF



Visual indication of

<p>Cylinder stroke < 2,5 mm</p>	<p>Maximum brake pad temperature</p>	<p>Air gap difference between disc and pad surface by measuring the temperature difference between pads caused by unilateral pad rubbing</p>	<p>Contact force</p>
---	---	---	----------------------

Description CMB2-SF



Main Features

Industrial display with 4 rows of 20 characters for indication of measurement data and error messages	Up to 5 m cable length from sensor to electronic box.
High ambient temperature range – 20°C.....+70°C (-4°F.....158°F)	Brake operation cycle counter
Protection class IP66	Supply voltage selection switch 115/230 V AC
Internal keypad for parameter change	Profibus connection. All scaled measure signals and error bits are transferred by bus system to the main control PLC. No expensive analogue inputs in customers PLC are required!

Parts of the system

Supply voltage The electronic unit can be connected directly to 110-240 V AC (50/60 Hz) supply voltage. The internal voltage selector switch must be set by the user to the corresponding position 115 or 230 V	Stroke sensor These analogue sensors (S1, S2) measure the stroke of the piston. If the rated stroke of 2 mm/side increases beyond the maximum value due to pad wear. If the value is higher than 2.5 mm, the customer should readjust the stroke back to 2.0 mm in accordance with the manual. Failure to do so can result in a reduced braking performance. Again a signal bit is set to flag the problem to the control PLC.
Display All measured analogue and digital signals and error messages are shown on the display in English language. Other languages are available on request. The display is readable under direct sunshine (outdoor and container crane applications) and has a LED backlight for use in a dark environment, such as steel mills.	Proximity switch release control These 2 switches (S5 S6) are independent from the CMB2-SF and have to be connected directly to the main control PLC to be active.
Keypad With the internal key pad, the user can adjust parameters such as changing the temperature display from Celsius (°C) to Fahrenheit (°F) or setting of the Profibus address.	Relay contact A dry contact (max 250 V 2 A) is connected to terminals 21/22. It is closed in normal status of the CMB2 and open, if the system is in error mode, or switched off. If no Profibus is available, this contact can be connected to main control PLC input, to give a common error signal.
Reset button The LED pushbutton on top of the electronic box indicates that the brake is outside its normal operating parameters by a flashing red light. When the problem on the brake is solved, the status of the CMB2-SF can be reset by pushing the button. The unit cannot be reset until the adjustments are made and the problem solved.	Profibus All scaled measured data and warning signals are transferred by the Profibus-DP slave port to the main control PLC. No expensive analogue inputs (6 pcs. per brake) are required in PLC. The address of the DP slave can be easily set in the unit by a parameter change in the software. Up to 126 brakes can be connected to one Profibus master.
Pad temperature sensor A pair of Pt100 sensors (R1, R2) measure the temperature of each brake pad. If the temperature is too high, or unequal between left, or right hand side the unit generates a signal that can be sensed by the main control PLC to warn the operator that attention is required.	
Contact force sensor A load cell located in each brake cylinder (S3 S4) measures the contact force of the spring pack. This signal is used to detect a spring failure or malfunction of the hydraulic system.	

Options

Stainless steel electronic box IP66 for outdoor use

Monitoring System CMB2-SF

Dimensions and technical data



Rev. 12-06

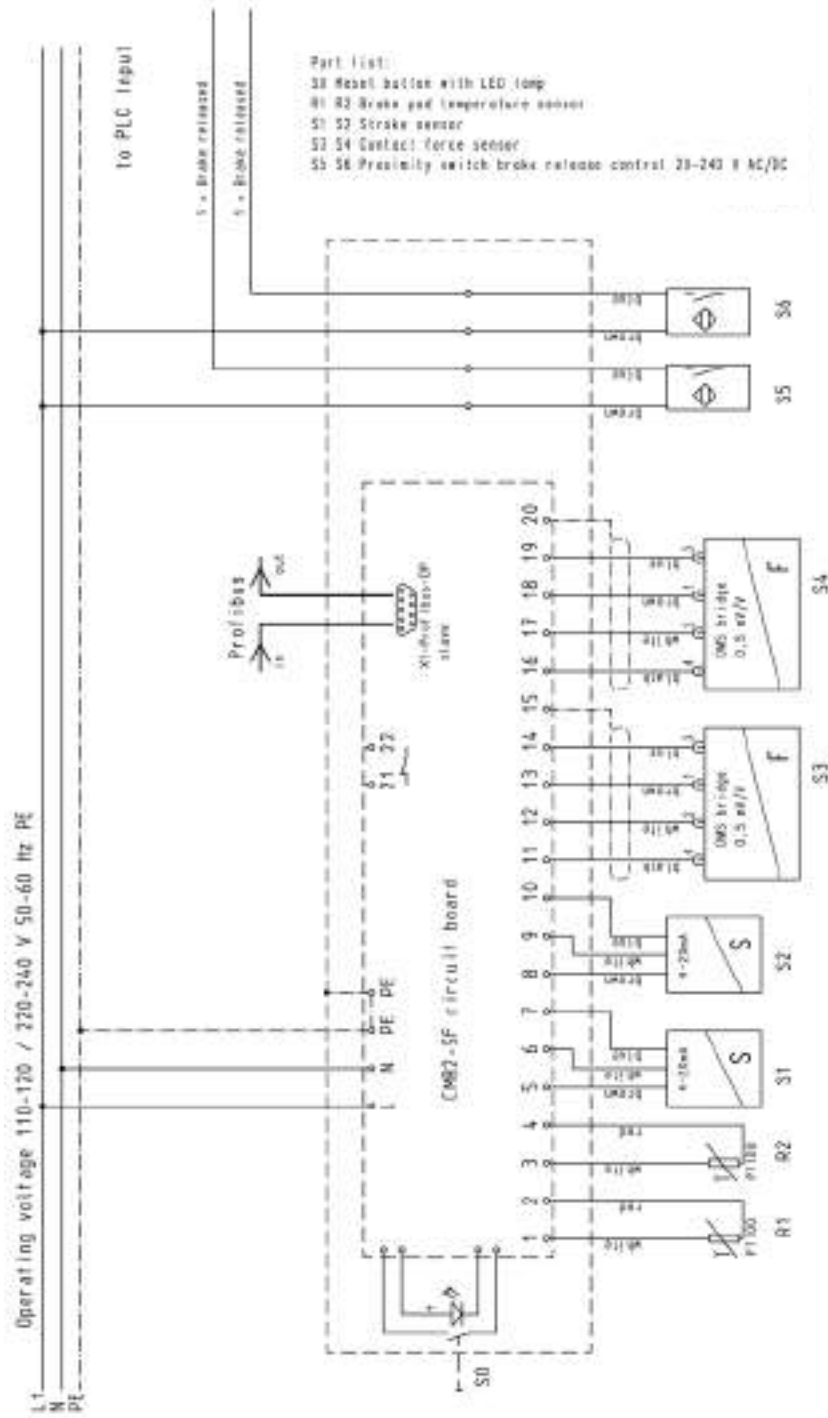

Gas-Hydraulic Buffer PB



PINTSCH BUBENZER
is certified according to
DIN EN ISO 9001:2015

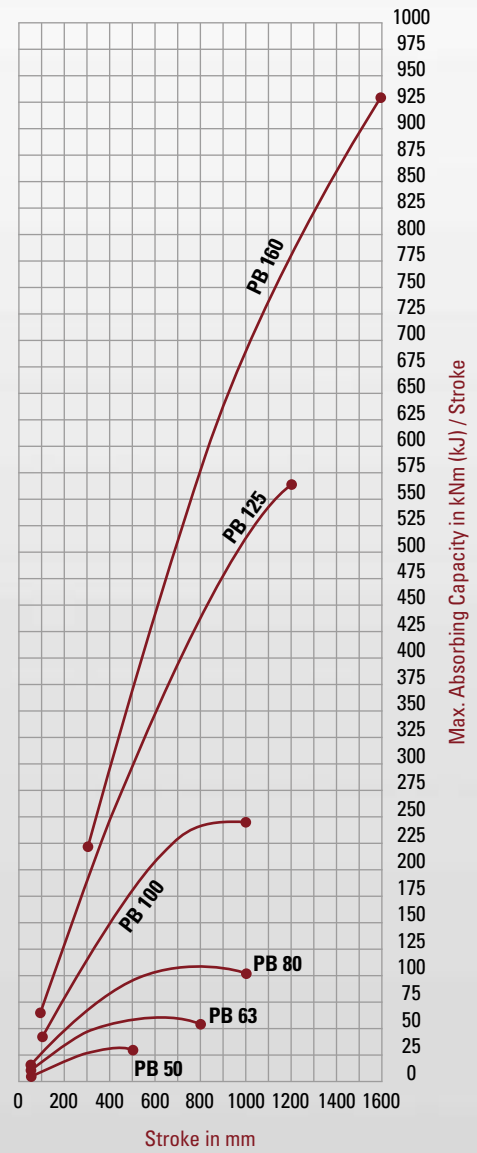

Efficient



Low Maintenance



Reliable



Robust Design

Description PB Buffer



Main Features

- Piston and cylinder of special seamless pipes
- Back mounted or front mounted versions available
- Piston rod IONIT-OX coated (plasma nitriding process)
- Impact speed sensitive damping
- Low maintenance

Options

- Special mounting flanges on request
- Special high and low temperature design
- Safety wire rope
- Protection bellows
- Special design on request
- Seawater resistant paint on request

Ordering Example

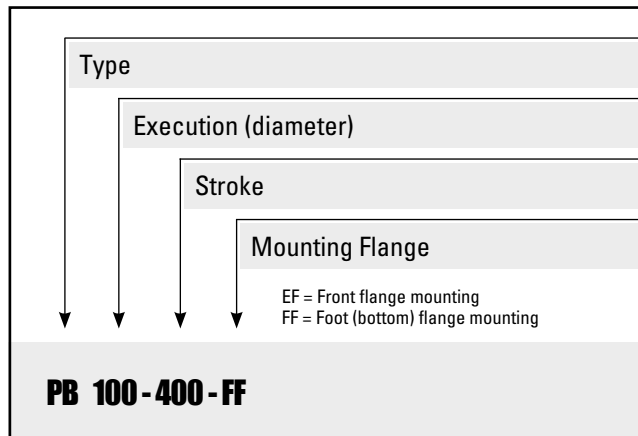

Applications

As impact energy absorber on crane gantries, trolleys, elevators, stackers, reclaimers and other industrial equipment



Please Note

We supply a detailed operating manual with every order. Nevertheless, we would point out that buffers are only as safe as the servicing and maintenance performed while they are in operation. The guarantee for the correct functioning of our buffers is therefore only valid if the user adheres to the installation and operating manual.



PINTSCH BUBENZER Service

This includes the verification of the brake selection, if required. A detailed questionnaire is provided for this purpose. Installation and commissioning on-site by PINTSCH BUBENZER service engineers is possible. Drawings as DWG/DXF files for your engineering department are available upon request.

Buffer Type PB 50

Dimensions and technical data



Rev. 01-16

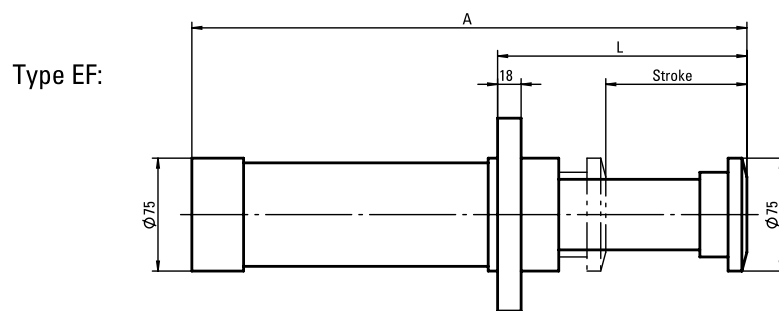
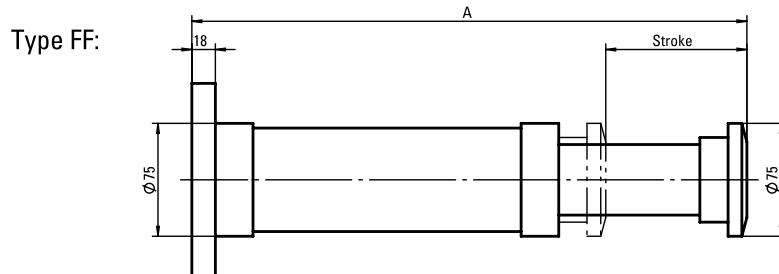

Flange:

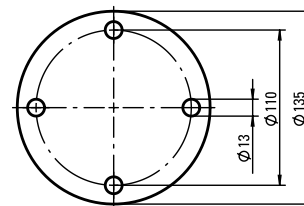

EF = front flange mounting
FF = foot (bottom) flange mounting

All dimensions in mm
Alterations reserved without notice

Stroke	Energy Stroke	* Energy h	Max. buffer force	Inward force	Weight	** Perm. angular deviation	** Perm. angular deviation	A	L
EF FF mm	EF FF kNm (kJ)	EF FF kNm (kJ)	EF FF kN	EF FF kN	EF FF kg	FF degree	EF degree	EF FF mm	EF mm
50	4,5	400	100	5,0	6,6	4,5	5,5	270	145
100	9,0	650	100	6,0	8,2	3,2	4,0	410	195
150	13,6	950	100	6,0	9,8	2,1	2,9	550	245
200	18,1	1250	100	7,0	11,2	1,5	2,3	685	295
250	22,7	1600	100	7,0	12,6	1,3	2,1	825	345
300	27,2	1900	100	7,0	14,0	1,2	1,9	965	395
350	28,6	2000	90	7,0	15,5	1,1	1,8	1105	445
400	29,0	2100	80	7,5	16,9	1,0	1,7	1235	495
450	28,6	2200	70	7,5	18,2	-	1,6	1375	545
500	27,2	2200	60	7,5	19,5	-	1,5	1515	595

* At an ambient temperature of 30°C

** Relating to the max. permissible buffer force

Buffer Type PB 63

Dimensions and technical data



Rev. 02-16

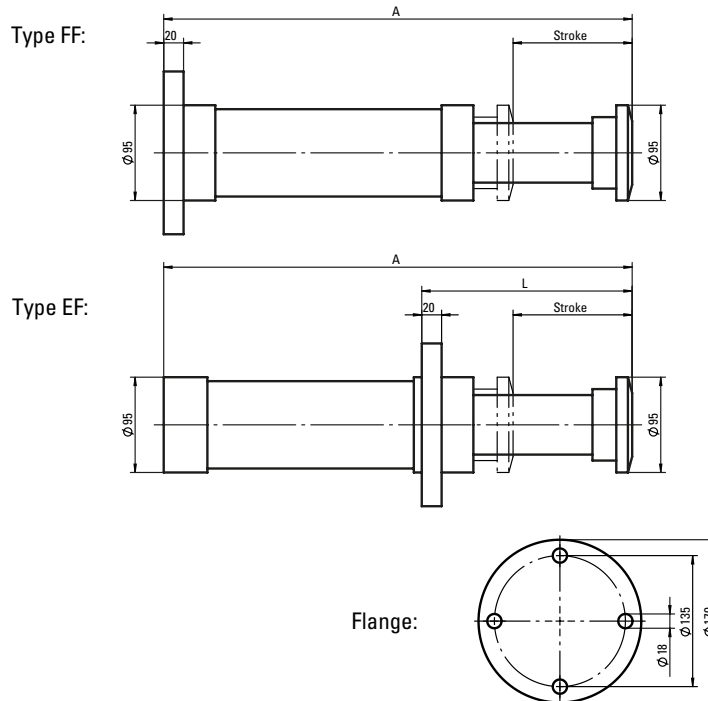

EF = front flange mounting
FF = foot (bottom) flange mounting

All dimensions in mm
Alterations reserved without notice

Stroke	Energy Stroke	* Energy h	Max. buffer force	Inward force	Weight	** Perm. angular deviation	** Perm. angular deviation	A	L
EF FF mm	EF FF kNm (kJ)	EF FF kNm (kJ)	EF FF kN	EF FF kN	EF FF kg	FF degree	EF degree	EF FF mm	EF mm
50	7,7	600	170	8,0	10,5	4,2	5,0	280	155
100	15,4	1200	170	8,0	13,5	3,2	4,0	425	205
150	23,1	1600	170	9,0	16,0	2,2	3,0	560	255
200	30,9	1850	170	10,0	18,0	1,8	2,4	700	305
250	38,6	2100	170	11,0	20,5	1,6	2,2	835	355
300	46,3	2400	170	11,0	23,0	1,5	2,1	975	405
350	50,9	2600	160	12,0	25,5	1,4	2,0	1115	455
400	54,5	2800	150	12,0	28,0	1,3	1,9	1255	505
450	57,2	2900	140	12,0	30,5	1,2	1,8	1395	555
500	59,0	3000	130	12,0	33,0	1,1	1,6	1535	605
550	60,0	3000	120	15,0	35,0	-	1,5	1650	655
600	60,0	3000	110	15,0	37,0	-	1,4	1785	705
650	59,0	3000	100	15,0	39,5	-	1,3	1925	755
700	57,2	3200	90	15,0	42,0	-	1,2	2060	805
750	54,5	3200	80	15,0	44,5	-	1,1	2200	855
800	50,9	3200	70	15,0	47,0	-	1,0	2340	905

* At an ambient temperature of 30°C
** Relating to the max. permissible buffer force

Buffer Type PB 80

Dimensions and technical data



Rev. 02-16

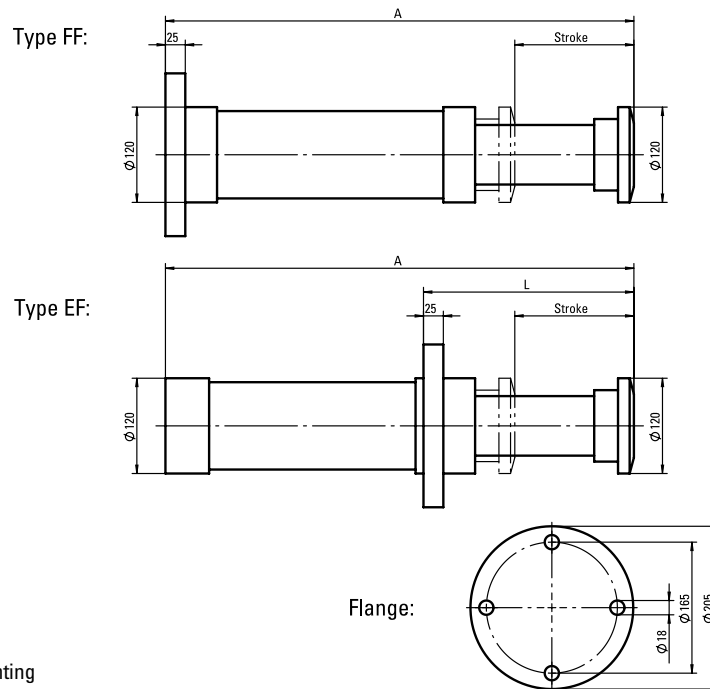

EF = front flange mounting
FF = foot (bottom) flange mounting

All dimensions in mm
Alterations reserved without notice

Stroke	Energy Stroke	* Energy h	Max. buffer force	Inward force	Weight	** Perm. angular deviation	** Perm. angular deviation	A	L
EF FF mm	EF FF kNm (kJ)	EF FF kNm (kJ)	EF FF kN	EF FF kN	EF FF kg	FF degree	EF degree	EF FF mm	EF mm
50	11,8	600	260	12,0	20	4,2	5,5	290	175
100	23,6	1000	260	12,0	24	24	4,8	440	225
150	35,4	1700	260	12,0	28	28	4,0	590	275
200	47,2	2200	260	12,0	33	33	3,2	740	325
250	59,0	2600	260	15,0	36	36	2,8	870	375
300	68,1	2800	250	15,0	40	40	2,5	1015	425
350	76,3	3000	240	15,0	45	45	2,2	1160	475
400	83,6	3200	230	17,0	48	48	2,0	1285	525
450	90,0	3500	220	17,0	52	52	1,8	1430	575
500	95,4	3800	210	17,0	56	56	1,6	1570	625
550	100,0	4000	200	17,0	60	60	1,5	1715	675
600	103,6	4200	190	17,0	65	65	1,4	1860	725
650	106,3	4300	180	17,0	69	69	1,3	2000	775
700	108,1	4400	170	17,0	73	73	1,2	2145	825
750	109,0	4400	160	17,0	76	76	1,1	2290	875
800	109,0	4500	150	20,0	79	79	1,0	2395	925
900	106,3	4500	130	20,0	88	88	0,9	2685	1025
1000	100,0	4500	110	20,0	96	96	0,8	2970	1125

* At an ambient temperature of 30°C

** Relating to the max. permissible buffer force

Buffer Type PB 100

Dimensions and technical data



Rev. 02-16

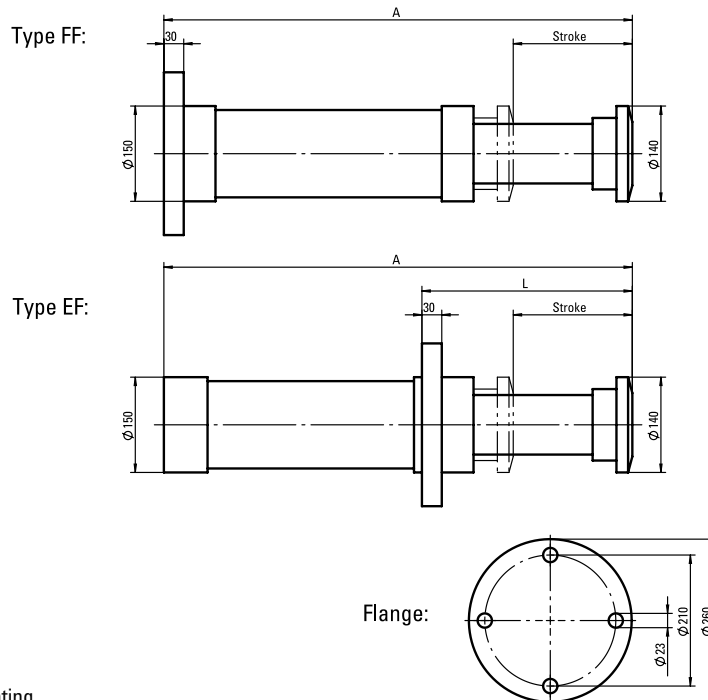

EF = front flange mounting
FF = foot (bottom) flange mounting

All dimensions in mm
Alterations reserved without notice

Stroke	Energy Stroke	* Energy h	Max. buffer force	Inward force	Weight	** Perm. angular deviation		A	L
						FF degree	EF degree		
EF FF mm	EF FF kNm (kJ)	EF FF kNm (kJ)	EF FF kN	EF FF kN	EF FF kg	FF degree	EF degree	EF FF mm	EF mm
100	39	1700	430	20	42	5,0	6,0	460	255
150	59	2300	430	20	49	4,5	5,2	600	305
200	78	2750	430	25	57	4,0	4,5	735	355
250	98	3300	430	25	63	3,5	4,0	875	405
300	117	4000	430	25	70	3,0	3,5	1015	455
350	134	4800	420	25	77	2,2	3,0	1165	505
400	149	5500	410	30	84	1,8	2,5	1280	555
450	163	5850	400	30	90	1,6	2,2	1420	605
500	177	6150	390	30	95	1,4	2,0	1560	655
550	190	6450	380	30	100	1,2	1,9	1695	705
600	202	6700	370	30	106	1,0	1,8	1840	755
650	212	7000	360	30	112	-	1,7	1980	805
700	222	7300	350	30	117	-	1,6	2120	855
750	232	7600	340	30	123	-	1,5	2260	905
800	240	7800	330	30	129	-	1,4	2400	955
900	245	8000	300	30	144	-	1,2	2675	1055
1000	245	8200	270	30	160	-	1,0	2955	1155

* At an ambient temperature of 30°C
** Relating to the max. permissible buffer force

Buffer Type PB 125

Dimensions and technical data



Rev. 02-16

Type FF:

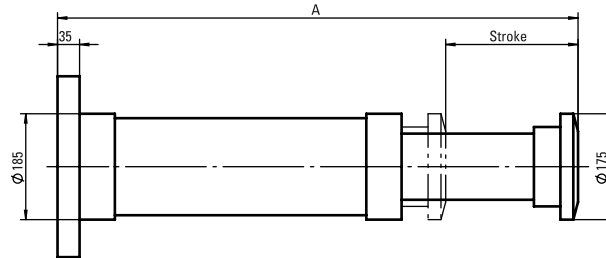

Type EF:

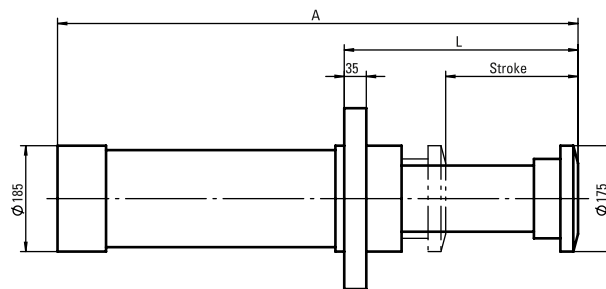

Flange:

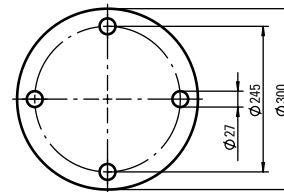

EF = front flange mounting
FF = foot (bottom) flange mounting

All dimensions in mm
Alterations reserved without notice

Stroke	Energy Stroke	* Energy h	Max. buffer force	Inward force	Weight	** Perm. angular deviation	** Perm. angular deviation	A	L
EF FF mm	EF FF kNm (kJ)	EF FF kNm (kJ)	EF FF kN	EF FF kN	EF FF kg	FF degree	EF degree	EF FF mm	EF mm
100	62	1800	680	55	60	5,5	6,5	470	251
150	93	2700	680	55	72	5,0	6,0	590	301
200	124	3500	680	55	83	4,4	5,4	730	351
250	155	4300	680	55	95	3,8	4,8	870	401
300	185	5000	680	60	108	3,0	4,0	1000	451
400	247	6500	680	60	133	2,2	3,2	1270	551
500	300	7300	660	60	148	1,5	2,8	1550	651
600	349	8000	640	70	162	1,0	2,4	1800	751
700	394	9000	620	80	182	-	2,2	2050	851
800	436	10000	600	90	198	-	2,0	2300	951
900	474	11000	580	90	215	-	1,8	2560	1051
1000	509	12000	560	90	230	-	1,6	2830	1151
1200	567	13000	520	95	260	-	1,2	3350	1351

* At an ambient temperature of 30°C

** Relating to the max. permissible buffer force

Buffer Type PB 160

Dimensions and technical data



Rev. 02-16

Type FF:

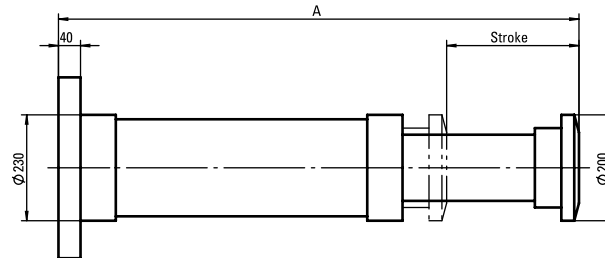

Type EF:

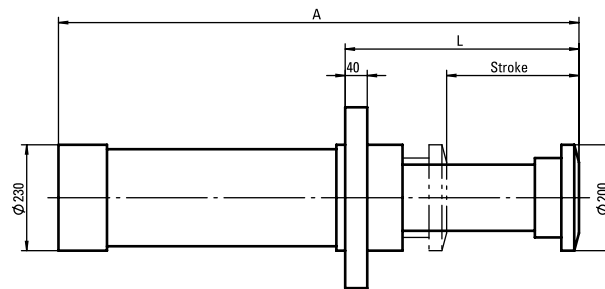

Flange:

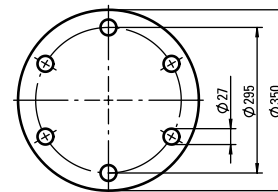

EF = front flange mounting
FF = foot (bottom) flange mounting

All dimensions in mm
Alterations reserved without notice

Stroke	Energy Stroke	* Energy h	Max. buffer force	Inward force	Weight	** Perm. angular deviation	** Perm. angular deviation	A	L
EF FF mm	EF FF kJ	EF FF kJ	EF FF kN	EF FF kN	EF FF kg	FF degree	EF degree	EF FF mm	EF mm
300	218	5800	800	85	175	2,4	4,0	1080	420
400	290	7000	800	85	206	2,2	3,5	1370	520
500	363	8300	800	85	237	1,8	3,2	1660	620
600	436	9500	800	85	268	1,3	3,0	1950	720
700	509	10500	800	85	299	-	2,8	2240	820
800	581	11500	800	85	330	-	2,6	2530	920
900	638	12000	780	90	361	-	2,4	2820	1020
1000	690	13500	760	90	391	-	2,2	3100	1120
1100	740	14200	740	120	407	-	2,0	3300	1220
1200	785	15000	720	160	427	-	1,8	3500	1320
1300	827	15300	700	160	454	-	1,6	3780	1420
1400	865	15700	680	160	481	-	1,4	4050	1520
1500	900	16000	660	160	511	-	1,2	4330	1620
1600	930	17000	640	160	539	-	1,0	4600	1720

* At an ambient temperature of 30°C
** Relating to the max. permissible buffer force



© 2018 PINTSCH BUBENZER

www.pintschbubenzler.com



3rd edition

PINTSCH BUBENZER GmbH

Friedrichshuetttenstr. 1
D-57548 Kirchen-Wehbach
Phone +49 27 41/94 88-0

Huenxer Str. 149
D-46537 Dinslaken
Phone +49 20 64/602-0

www.pintschbubenzler.com