

more information: www.buel-bubenzner.com



BUEL[®]
STRONG **S**

The BUEL[®] Model S is a brand new family member of the PINTSCH BUBENZER brand BUEL[®]. It is designed for wheel brakes on rail mounted cranes, where high pulling forces for mechanical wheel brakes are required. The patented cylinder system generates pulling forces up to 40.000 N. It has a robust, but also compact design for rough environmental conditions. Our experts will assist you to find your best solution with BUEL[®].

Electrical design

All BUEL® Model S units are operated with 3-phase voltages between 220 V to 690 V at 50 Hz or 60 Hz.

Protection class

The electric components of the BUEL® Model S thrusters are located inside, for best protection against environmental influences. BUEL® thrusters are rated IP 65. Protection class IP 67 is available as an option.

Operating modes

BUEL® thrusters are designed for intermittent duty, independent from the required operating mode of the associated drive. No limitation of the BUEL® thruster duty cycle is required, because after reaching full stroke, (brake released) the motor is switched off. If full stroke is not reached in 4 seconds, the internal thruster motor switches off.

Ambient temperature range

BUEL® Model S thrusters are suitable for ambient temperatures between -30°C to +60°C*. For deviating ambient temperatures, please contact us for support.

Protection against moisture

For applications in maritime or tropic environments, the optional use of a small heater to protect the motor windings from moisture is recommended.

Heater voltages:

- > 110 to 120 V AC 50 Hz or 60 Hz
- > 220 to 240 V AC 50 Hz or 60 Hz

Hydraulic media

BUEL® Model S thrusters are filled with a high performance synthetic oil, type PENTOSIN CHF 11S. This oil insures a trouble-free operation in the entire temperature range, indicated above.

Biodegradable oil is available as an option.

Features

- > Pressure generation by centrifugal gear pump
- > Energy saving by intermittent duty
- > Fail safe principle
- > Redundant valves
- > Terminal box with control board
- > Automatic pressure drop compensation
- > Low heat generation
- > Huge temperature range in standard execution
- > Little oil volum
- > Little ecologic risk
- > High protection category
- > Infinitely variable setting time
- > Hand pump with shut-off valve
- > Low weight, excellent mass/performance ratio
- > Limit switch release control off the shelf

* Technical data relates to 3-phase 400 V, 50 Hz.

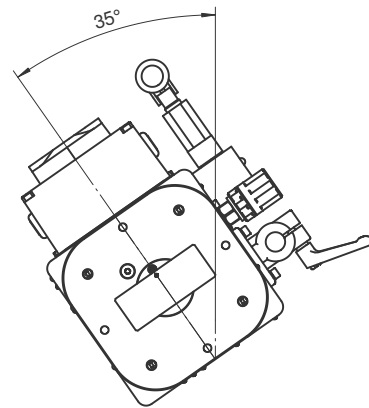
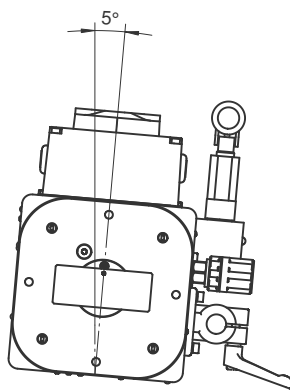
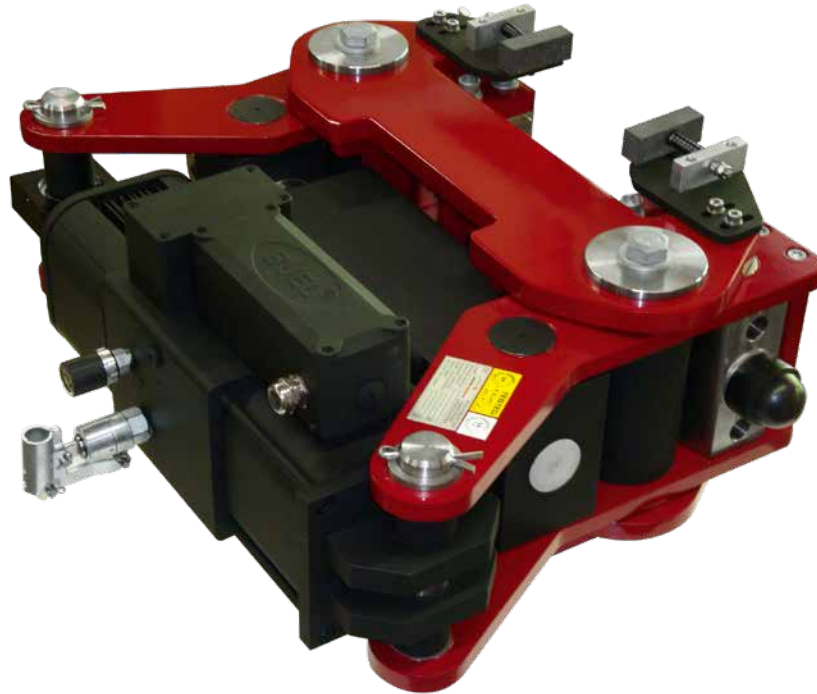

Installation positions

BUEL® Model S units are preferably operated in horizontal position. A deviation of +/- 2° from the horizontal plane is permitted. A rotation of 35° / 5° from the normal position is permitted.

Model S	Model S	Reset force (N)	Stroke (mm)	Max. power (KW)	Max. power consumption (A)	Mode of operation (c/h)	Weight with oil (kg)
3500-28	BRBe 70	35000	28	1,0	1,7	120	52
4000-28	BRBe 90	40000	28	1,1	1,8	120	52

Technical data relates to 3-phase 400 V, 50 Hz.

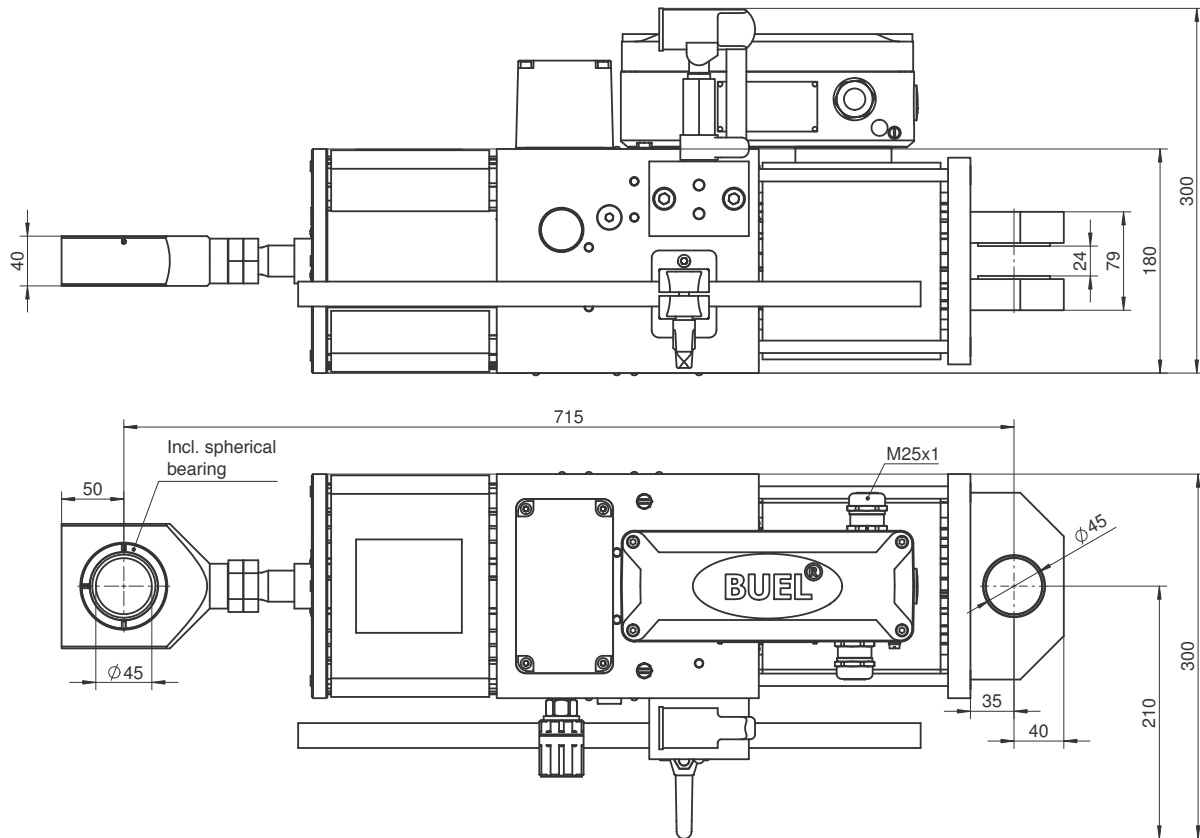

S	Type
3500	Max. pulling force in dN

Options	Type
A	Heater
C	Increased corrosion protection
I	Protection class IP67
M	Shut-off valve latching, non-latching
R	Shut-off valve latching
xxx V, yy Hz	Voltage, frequency

