

more information: [www.buel-bubbenzer.com](http://www.buel-bubbenzer.com)



**BUDEL<sup>®</sup>**  
**H**  
HIGH SPEED

The BUDEL<sup>®</sup> Model H is a family member of the PINTSCH BUBENZER brand BUDEL<sup>®</sup>. BUDEL<sup>®</sup> thrusters are used for almost all kind of industrial applications. They are setting new industry standards for disk and drum brakes as well as wheel brakes. Our experts will assist you to find your best solution with BUDEL<sup>®</sup>.

### Electrical design

All BUEL® thrusters are operated with 3-phase voltages between 220 V to 690 V at 50 Hz or 60 Hz.

### Protection class

All electric components of the BUEL® thrusters are located inside, for best protection against environmental influences. BUEL® thrusters are rated IP 65. As an option, protection class IP 67 is possible.

### Operating modes (BL 35-5 to BL 600-8)

BUEL® thrusters are designed for intermittent duty, independent from the required operating mode of the associated drive. No limitation of the BUEL® thruster duty cycle is required, because after reaching full stroke, (brake released) the motor is switched off. If full stroke is not reached in 4 seconds, the internal thruster motor switches off.

### Ambient temperature range

BUEL® thrusters are suitable for ambient temperatures between -30°C to +60°C\*. For deviating ambient temperatures, please contact us for support.

### Protection against moisture

For applications in maritime or tropic environments, the optional use of a small heater to protect the motor windings from moisture is recommended.

Heater voltages:

- > 110 to 120 V AC 50 Hz or 60 Hz
- > 220 to 240 V AC 50 Hz or 60 Hz

### Hydraulic media

BUEL® Model H thrusters are filled with a high performance synthetic oil, type PENTOSIN CHF 115. This oil insures a trouble-free operation in the entire temperature range, indicated above.

Biodegradable oil is available as an option.

### Properties

- > New technology
- > Pressure generation by centrifugal gear pump with high mechanical efficiency
- > Fast setting times
- > Energy saving by intermittent duty
- > Fail safe principle
- > Redundant valves
- > Terminal box with control board
- > Automatic pressure drop compensation
- > Low heat generation
- > Huge temperature range in standard execution
- > Little oil volume
- > Little ecologic risk
- > High protection category
- > Infinitely variable setting time
- > Swivel head for shear force and misalignment compensation
- > Unique design for the complete model range
- > Low weight, excellent mass/performance ratio

### Installation positions

All BUEL® thrusters are preferably operated vertically (piston rod on top). A deviation of +/- 30° from the vertical axis is permitted. A horizontal installation is possible as an option (please indicate with the order).

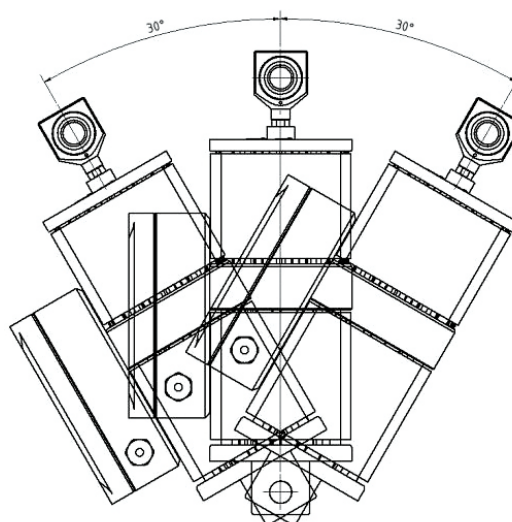

\* At 400 V, 50 Hz.

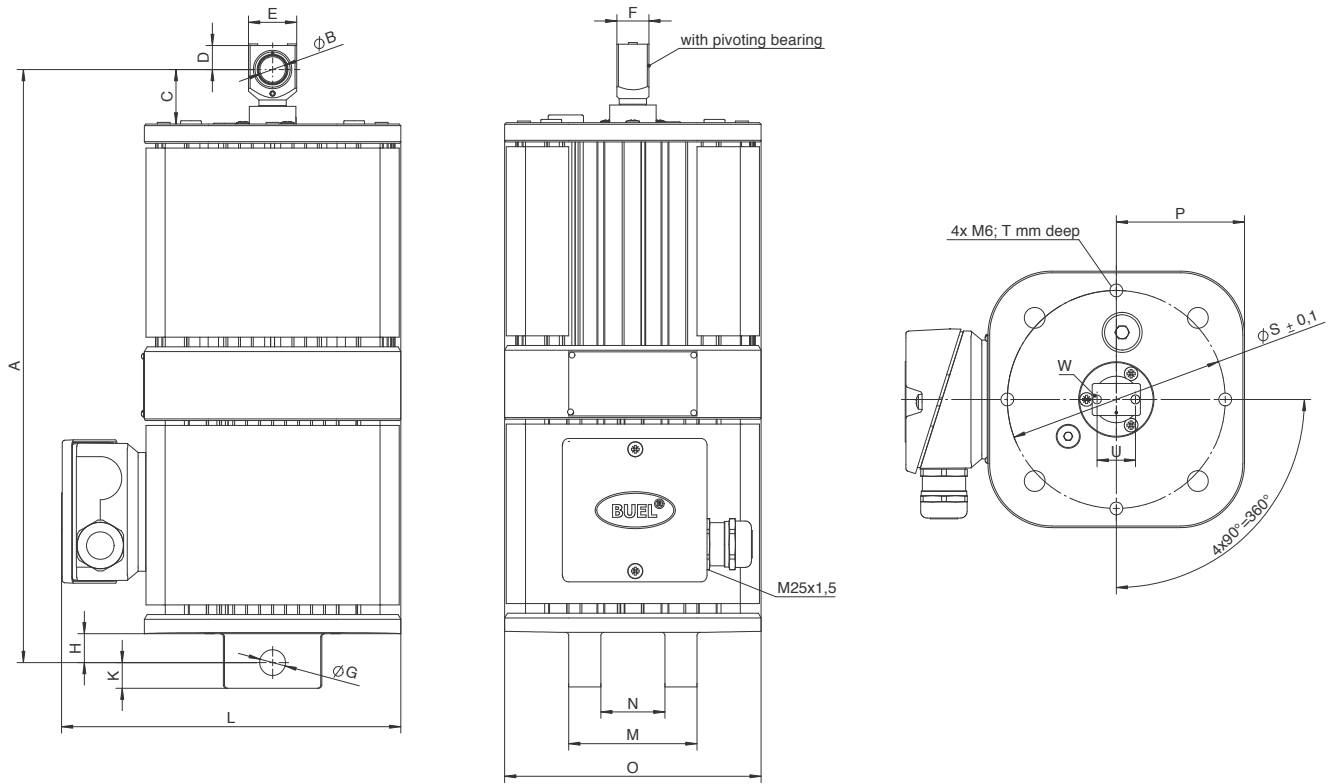

BL	F max. (N)	max. power (kW) *	max. current consumton (A) *	operating mode S1 and S3 to (c/h)	weight with hydraulic medium (kg)
22-5**	400	0,15	0,4	1000	11
30-5**	450	0,16	0,4	1000	13
35-5	600	0,35	0,6	1000	16
50-6	900	0,45	0,7	1000	16
50-12	900	0,45	0,7	1000	16
80-6	2000	0,60	1,3	1000	21
80-12	2000	0,60	1,3	1000	21
125-6	2500	0,65	1,4	1000	24
125-12	2500	0,65	1,4	1000	24
200-6	3600	0,80	1,5	1000	24
200-12	3600	0,80	1,5	1000	24
300-6	5000	0,90	1,6	900	33
300-12	5000	0,90	1,6	900	33
400-8	5500	1,0	1,7	900	33
400-10	5500	1,0	1,7	900	33
440-8	6500	1,10	1,8	900	33
450-6	7000	1,20	2,0	900	33
450-8	7000	1,20	2,0	900	33
550-8	8000	1,25	2,1	900	33
600-8	8000	1,25	2,1	900	33

\*At 400 V, 50 Hz. \*\*At temperature -30°C to +50°C (lower, respectively higher temperatures are possible on request).

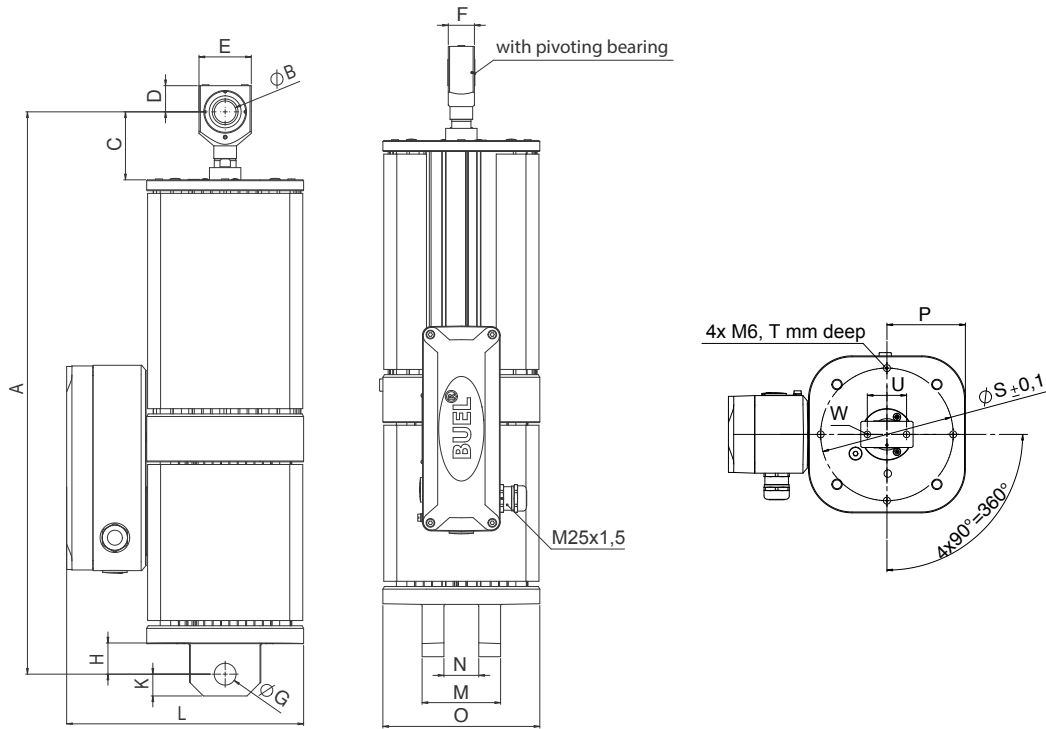

BL	F max.	A	B	C	D	E	F	G	H	K	L	M	N	O*	P	S	T	U	W
22-5	400 N	286	16	26	15	30	20	16	20	14	206	80	40	160	80	136	12	24	M4
30-5	450 N	370	16	34	15	30	20	16	18	16	210	80	40	160	80	136	12	24	M4
35-5	600 N	370	16	34	15	30	20	16	18	16	250	80	40	160	80	136	12	24	M4
50-6	900 N	435	20	94	25	50	25	20	23	22	250	120	60	160	80	136	12	35	M5
50-12	900 N	515	20	114	25	50	25	20	23	22	250	120	60	160	80	136	12	35	M5
80-6	2000 N	450	20	66	25	50	25	20	23	22	250	120	60	160	80	136	13	35	M5
80-12	2000 N	530	20	86	25	50	25	20	23	22	250	120	60	160	80	136	13	35	M5
125-6	2500 N	645	25	69	30	60	31	25	35	25	250	90	40	160	80	136	13	45	M5
125-12	2500 N	705	25	129	30	60	31	25	35	25	250	90	40	160	80	136	13	45	M5
200-6	3600 N	645	25	69	30	60	31	25	35	25	250	90	40	160	80	136	13	45	M5
200-12	3600 N	705	25	129	30	60	31	25	35	25	250	90	40	160	80	136	13	45	M5
300-6	5000 N	645	25	78	30	60	31	25	35	25	270	90	40	180	90	152	12,5	45	M5
300-12	5000 N	705	25	138	30	60	31	25	35	25	270	90	40	180	90	152	12,5	45	M5
400-8	5500 N	645	25	78	30	60	31	25	35	25	270	90	40	180	90	152	12,5	45	M5
400-10	5500 N	645	25	78	30	60	31	25	35	25	270	90	40	180	90	152	12,5	45	M5
440-8	6500 N	648	25	81	30	60	31	25	35	25	270	90	40	180	90	152	12,5	45	M5
450-6	7000 N	645	25	78	30	60	31	25	35	25	270	90	40	180	90	152	12,5	45	M5
450-8	7000 N	645	25	78	30	60	31	25	35	25	270	90	40	180	90	152	12,5	45	M5
550-8	8000 N	645	25	78	30	60	31	25	35	25	270	90	40	180	90	152	12,5	45	M5
600-8	8000 N	665	25	98	30	60	31	25	35	25	270	90	40	180	90	152	12,5	45	M5

\*Data without pressure and temperature monitoring.

BL	BUEL® Thrusters Series
80 (Example)	Type/Size
6 (Example)	Stroke

A	Heater
B	Cover (protection against dust)
C	Increased corrosion protection
D	application in active brakes
EB	Proximity switch
G	Version with internal or external proportional valve
H	High speed execution
I	Protection class IP 67
M	For controlled braking system BB900
N	BOSS® anti snag system
P	Deviating mounting position
R	Reserve stroke indication
S	Lowering valve
T	Temperature monitoring
W	High temperature execution
X	Special external certificates like e.g. UL
Z	Two stage braking action
xxxV, yy Hz	Voltage, frequency



## OPTION R (RESERVE STROKE INDICATOR BY LED)

Visual indication for „dropping below minimum permissible reserve stroke“, by two LED’s located on the terminal box. The option „reserve stroke indicator by LED“ makes it possible to monitor the lower threshold of the reserve stroke,

when the brake is set. When going below this threshold, the LED indicator changes from green light to red light. The LED’s are extremely bright. An indication even in direct sunlight is ensured (possible option for BL 125 and up).

## CERTIFICATE OF COMPLIANCE

Certificate Number 20190228- E492639  
Report Reference E492639-20170427  
Issue Date 2019-FEBRUARY-28

Issued to: PINTSCH BUBENZER GMBH  
Friedrichshuttenstr 1  
57548 Kirchen-Wehbach GERMANY

This certificate confirms that  
representative samples of

POWER CIRCUIT AND MOTOR-MOUNTED APPARATUS  
USL, CNL – Enclosed Type electrical Brake thruster Series  
BUEL, models BL 22-5, BL 30-5, BL 35-5, BL 50-6, BL 50-  
12, BL 80-6, BL 80-12, BL 125-6,  
BL 125-12, BL 200-6, BL 200-12, BL 300-6, BL 300-12, BL  
400-8, BL 400-10, BL 440-8, BL 450-6, BL 450-8, BL 550-8,  
BL 600-8 may be followed by A,B,C,G,K,M,N,O,P,S,U,Y,Z  
or X or in any of these letter combination.

Have been investigated by UL in accordance with the  
Standard(s) indicated on this Certificate.

Standard(s) for Safety: UL 508 and CSA 22.2 No. 14-13 Industrial Control  
Equipment

Additional Information: See the UL Online Certifications Directory at  
<https://iq.ulprospector.com> for additional information.

This *Certificate of Compliance* does not provide authorization to apply the UL Mark. Only the UL Follow-Up  
Services Procedure provides authorization to apply the UL Mark.

Only those products bearing the UL Mark should be considered as being UL Certified and covered under UL's  
Follow-Up Services.

Look for the UL Certification Mark on the product.



Bruce Mahrenholz, Director North American Certification Program

UL LLC

Any information and documentation involving UL Mark services are provided on behalf of UL LLC (UL) or any authorized licensee of UL. For questions, please  
contact a local UL Customer Service Representative at <https://ul.com/aboutus/contact>



# CERTIFICATE OF COMPLIANCE

[www.buel-bubenzler.com](http://www.buel-bubenzler.com)

**BL 22-5**

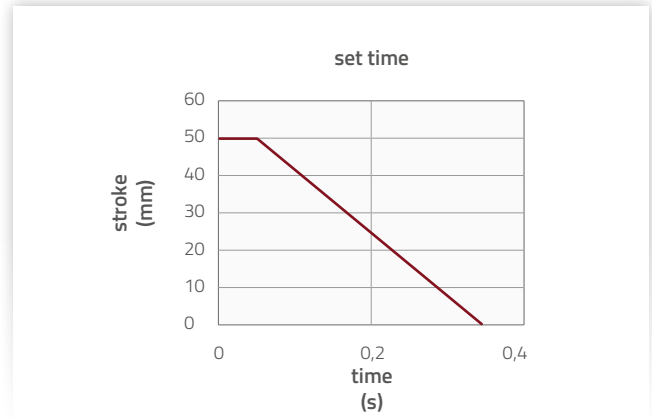
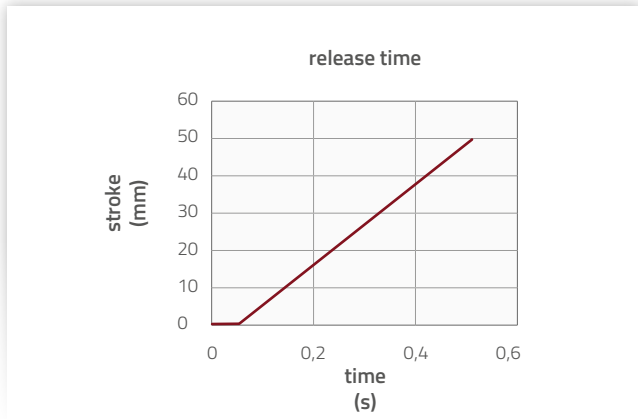

**BL 30-5**

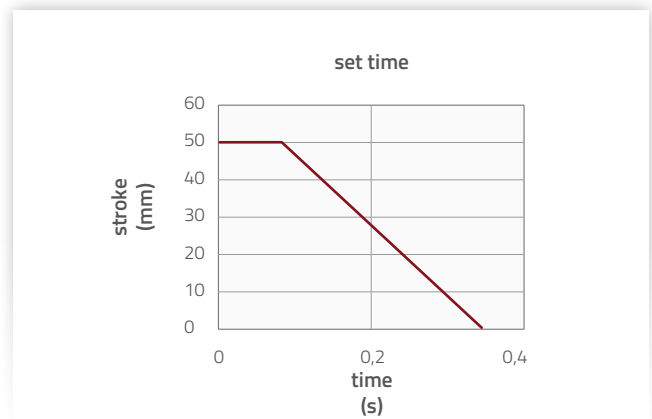
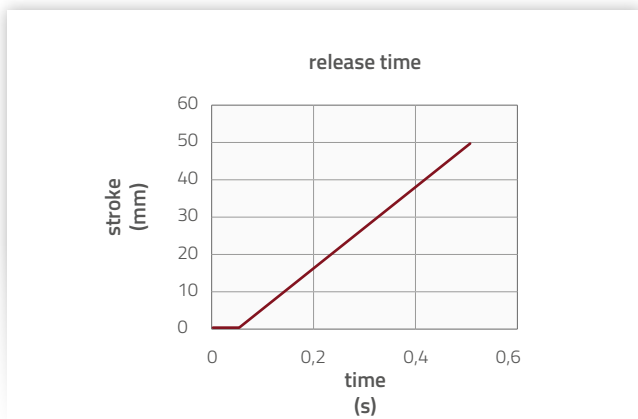

**BL 35-5**

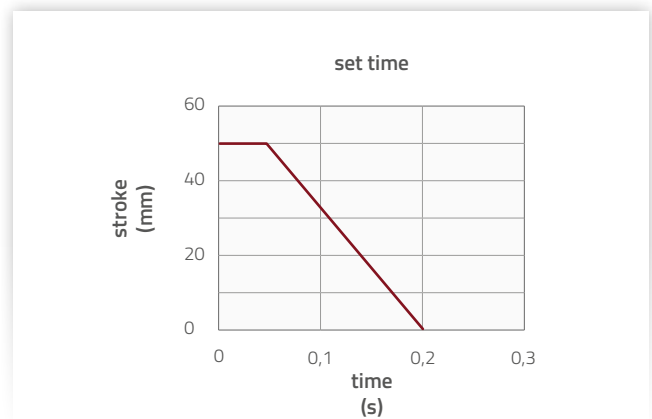
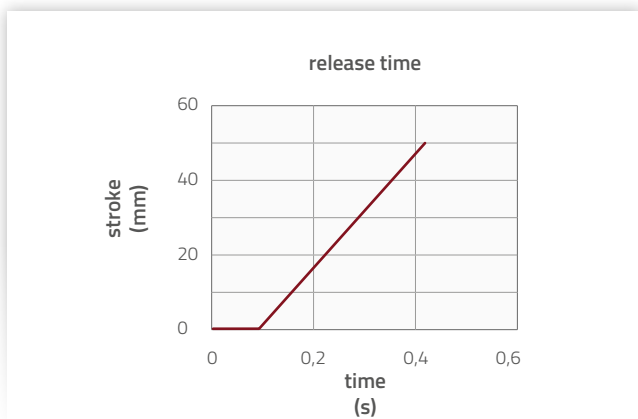

\* Weight load (N) according to BUEL® type/ size according to DIN 15430 or based on DIN 15430 Example: BL 80-6 - weight load 800 N (= 80 kp).



**BL 50-6**

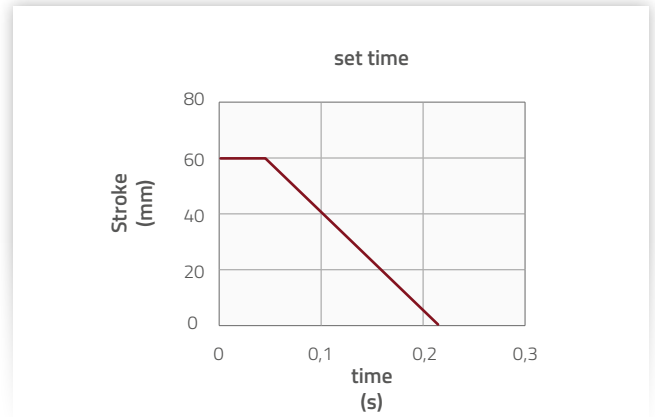
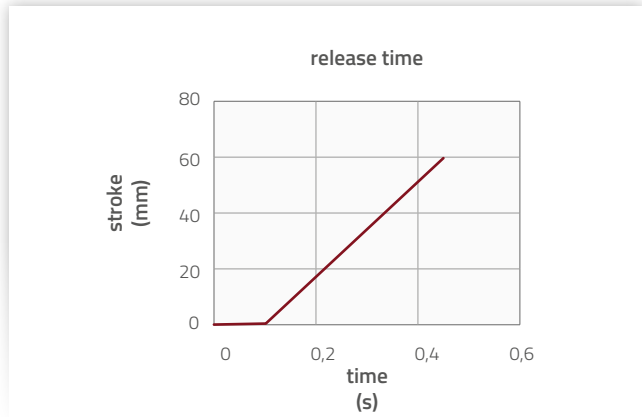

**BL 50-12**

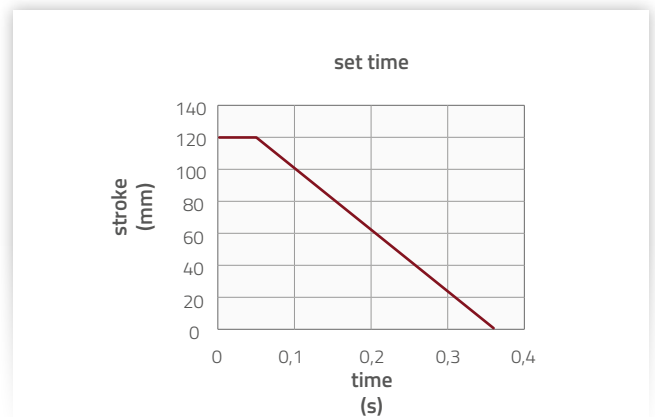
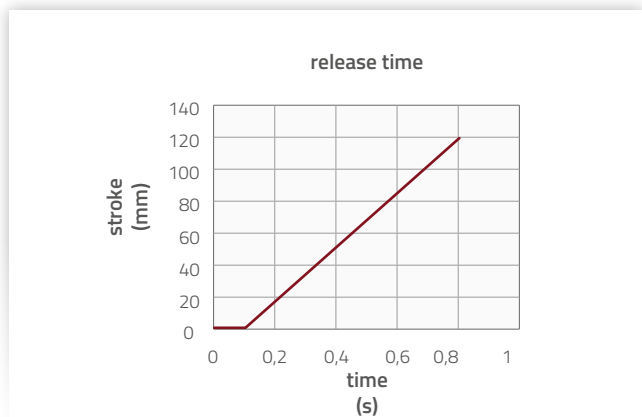

**BL 80-6**

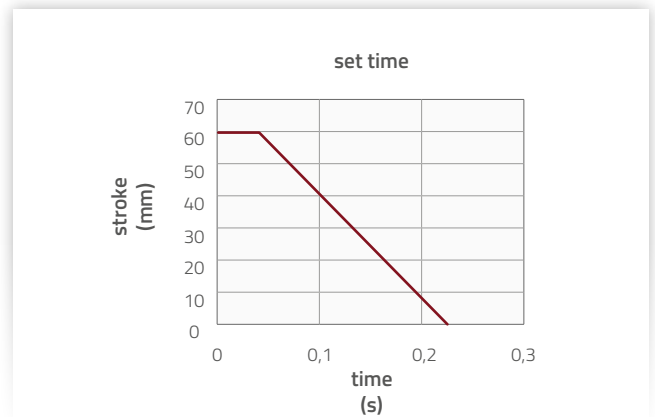
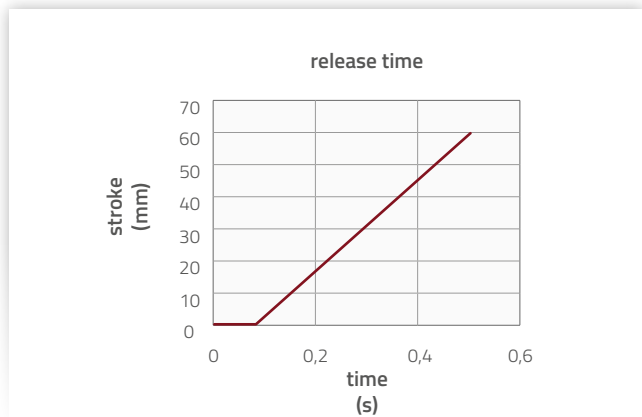

\* Weight load (N) according to BUEL® type/ size according to DIN 15430 or based on DIN 15430 Example: BL 80-6 - weight load 800 N (= 80 kp).



**BL 80-12**

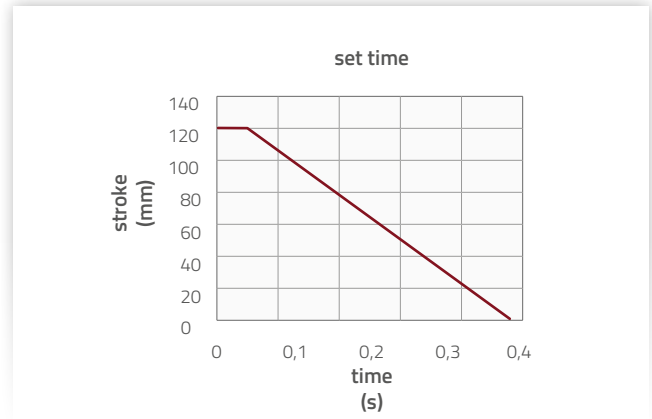
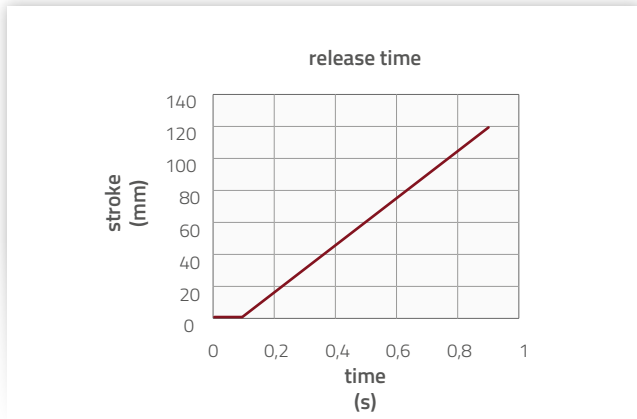

**BL 125-6**

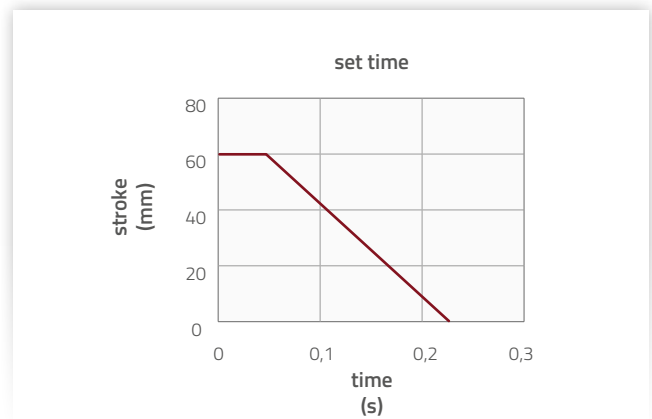
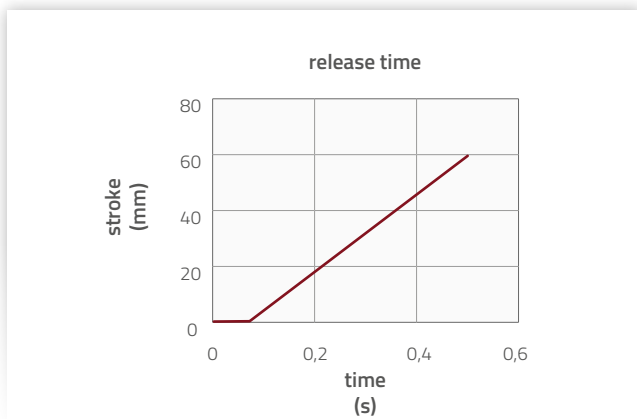

**BL 125-12**

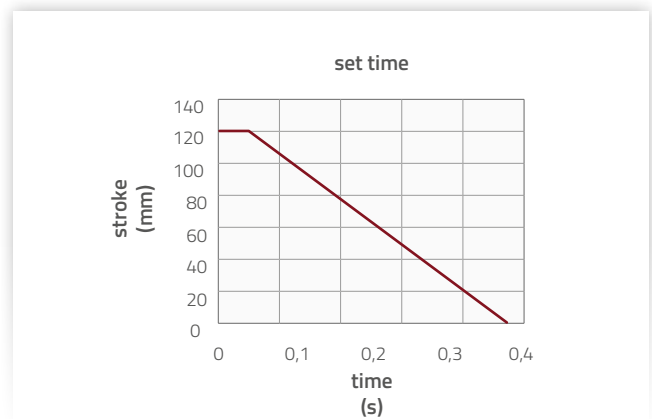
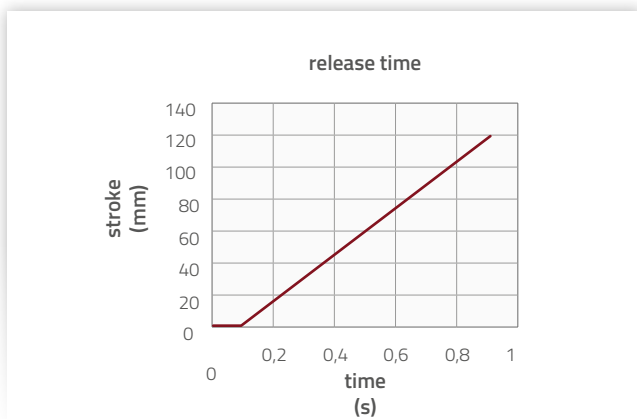

\* Weight load (N) according to BUEL® type/ size according to DIN 15430 or based on DIN 15430 Example: BL 80-6 - weight load 800 N (= 80 kp).

**BL 200-6**

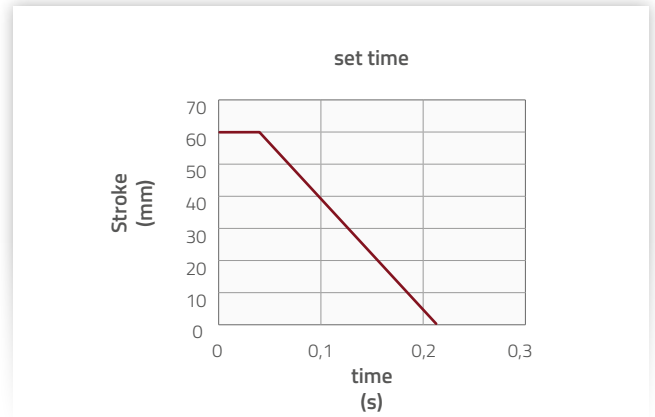
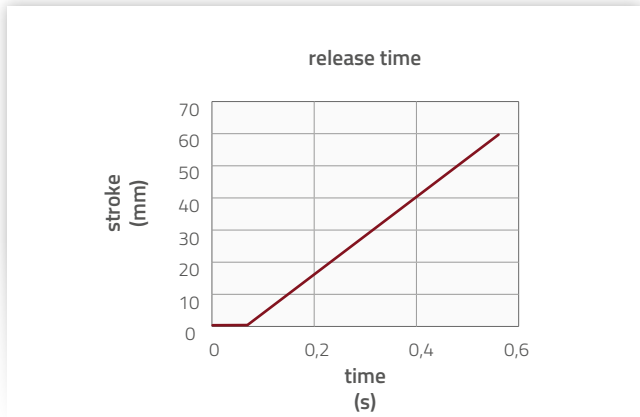

**BL 200-12**

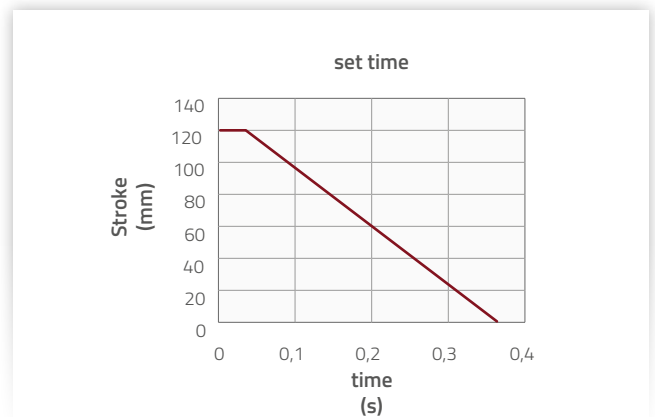
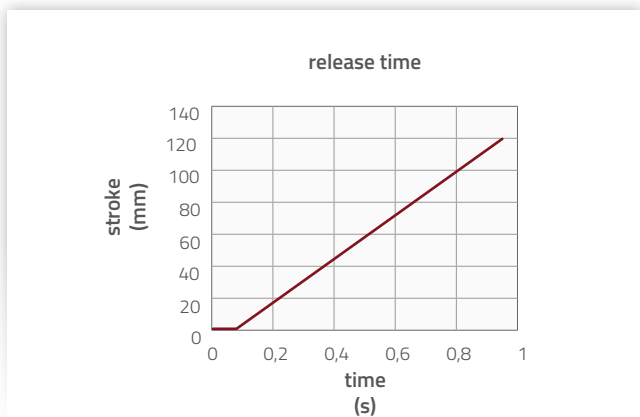

**BL 300-6**

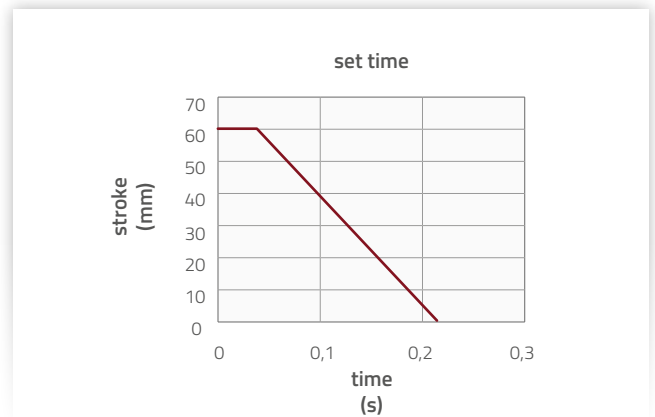
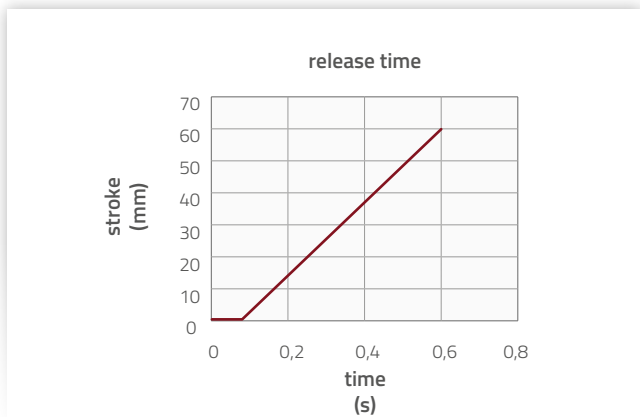

\* Weight load (N) according to BUEL® type/ size according to DIN 15430 or based on DIN 15430 Example: BL 80-6 - weight load 800 N (= 80 kp).

**BL 300-12**

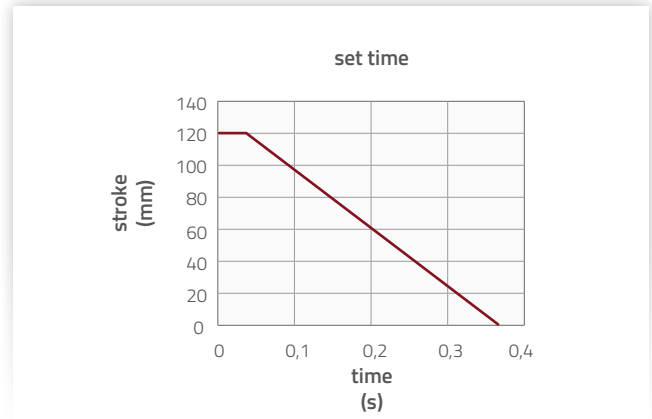
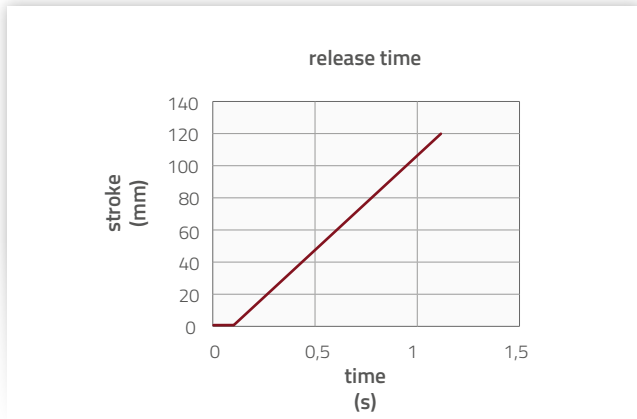

**BL 400-8**

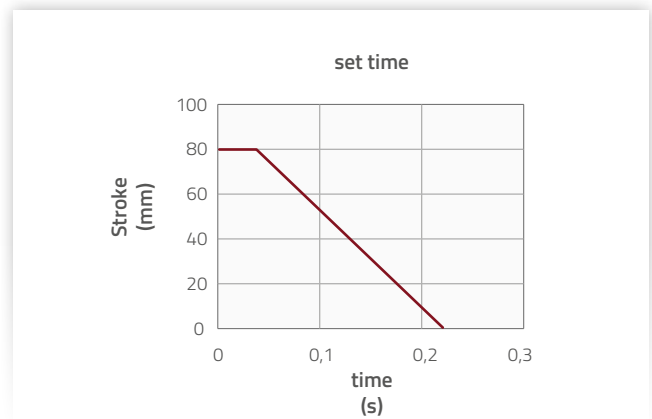
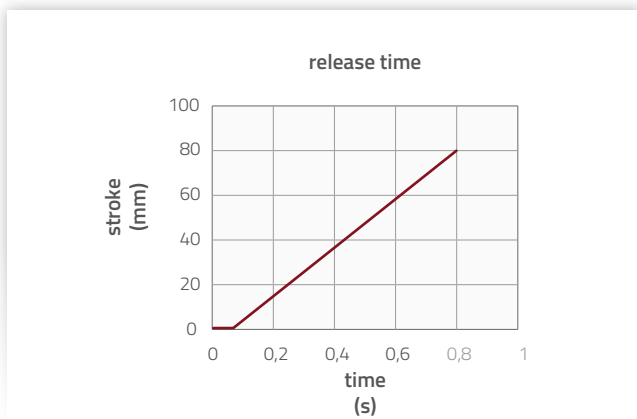

**BL 400-10**

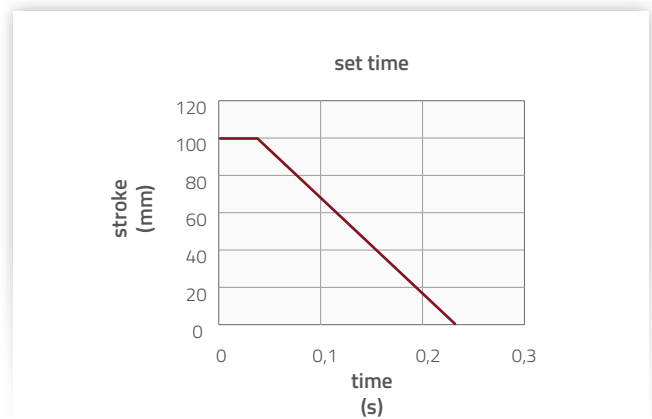
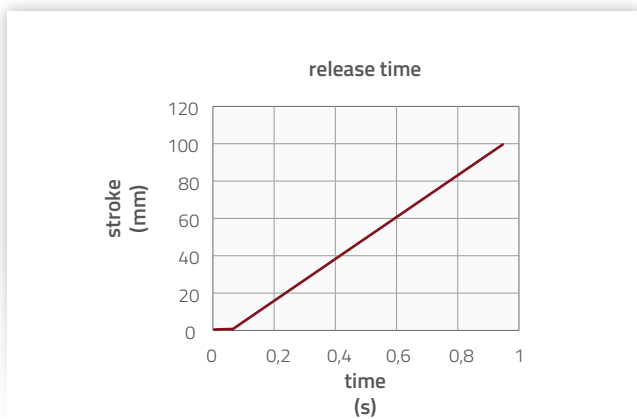

\* Weight load (N) according to BUEL® type/ size according to DIN 15430 or based on DIN 15430 Example: BL 80-6 - weight load 800 N (= 80 kp).

**BL 440-8**

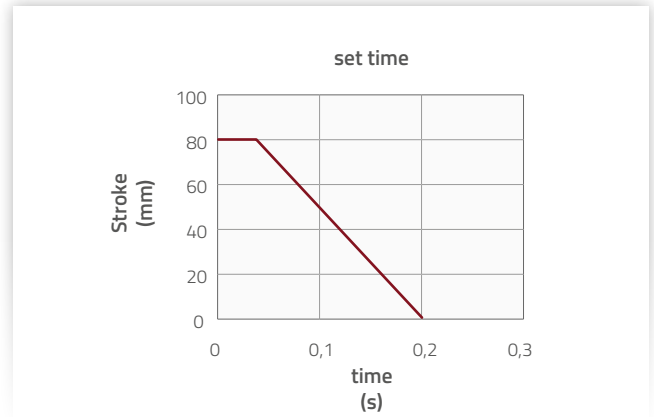
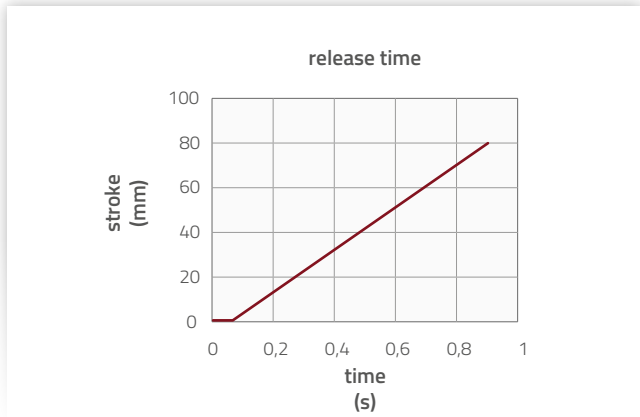

**BL 450-6**

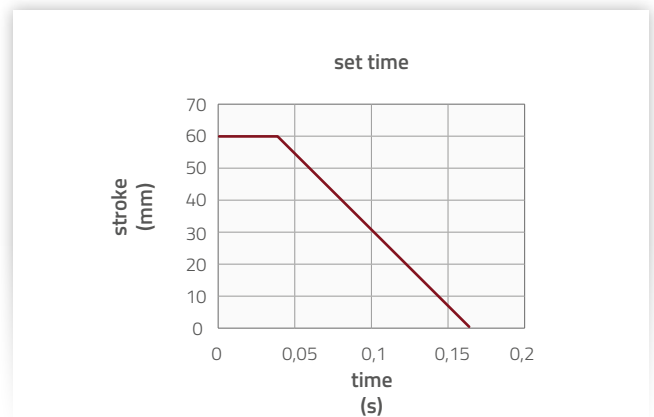
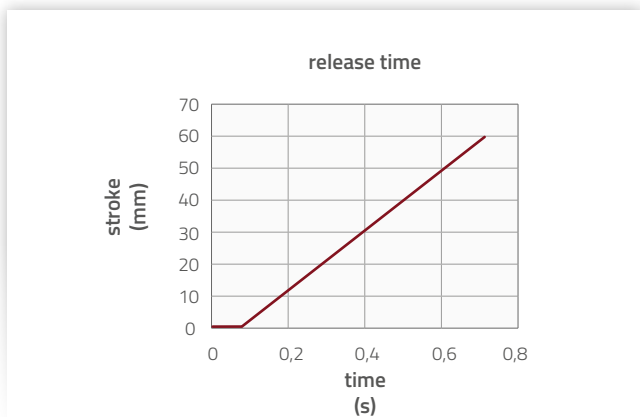

**BL 450-8**

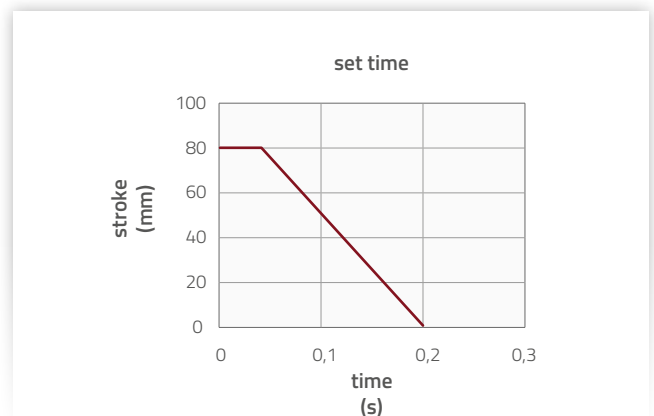
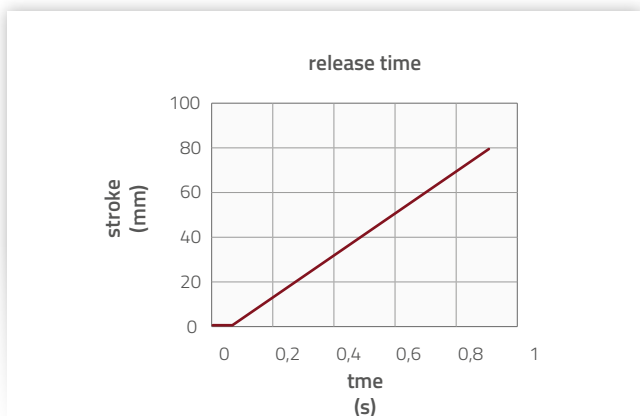

\* Weight load (N) according to BUEL® type/ size according to DIN 15430 or based on DIN 15430 Example: BL 80-6 - weight load 800 N (= 80 kp).

**BL 550-8**

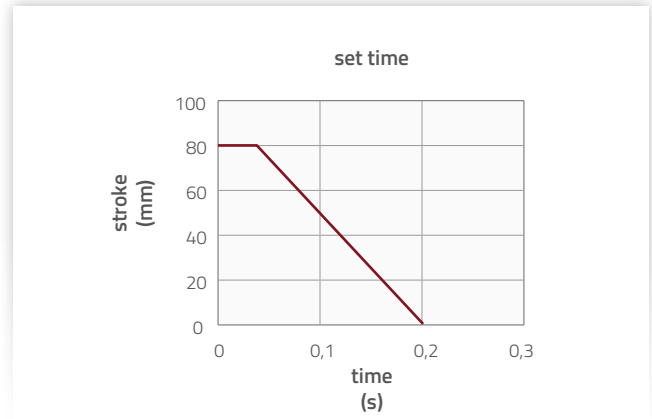
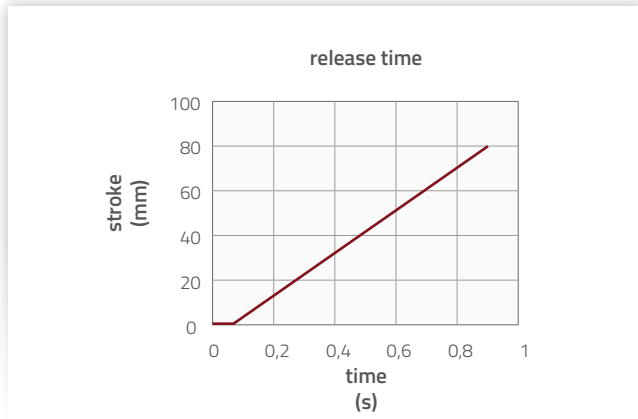

**BL 600-8**

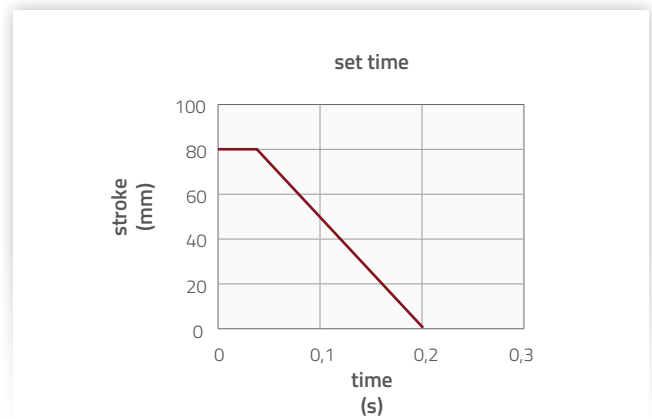
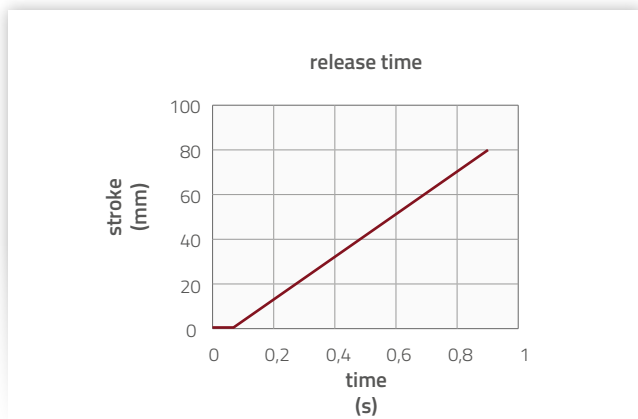

\* Weight load (N) according to BUEL® type/ size according to DIN 15430 or based on DIN 15430 Example: BL 80-6 - weight load 800 N (= 80 kp).